

**We make small parts
a big part of your bottom line.**

At ESP, we draw on our experience and apply our expertise at every stage of everything we do. Global insight, connection, and reach allow us to deliver the right engineered solutions at the right time. It's our passion for performance that leads to profitability for our OEM customers.



World Headquarters
5920 Dry Creek Lane NE
Cedar Rapids, IA 52402
Ph: 1.888.ESP.9002 (toll free)
Fx: 319.393.5327

www.espint.com

ESP Seals

MAD Seal *(Mud And Dirt)*
Patent Pending Pivot Joint Seal

**Prevents Contamination Ingression
Up to 50 Times Longer than O-ring Pivot Seals**



We make small parts a big part of your bottom line.





- Benefits:**
- **Up to 50 Times Longer Life** than O-ring Pivot Seals
**based on testing results on next page*
 - **Split Option** for Easy Field Replacement
 - **Cost-Effective**
 - Increased Machine Up Time
 - Reduced Service Time
 - Increased Life of Expensive Bearings

Advanced Technology O-Ring Replacement For Improved Machine Durability & Serviceability.

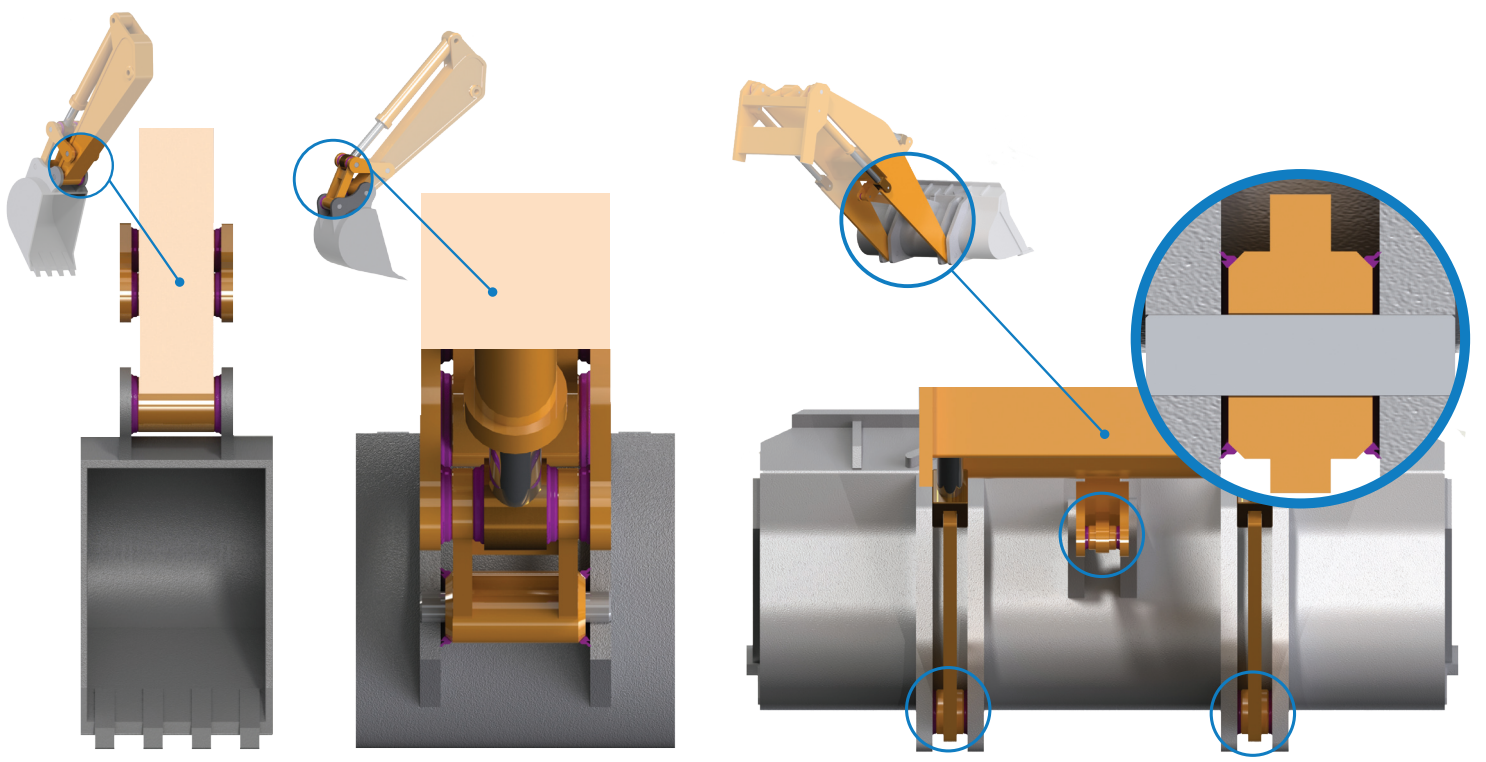

MAD Seal Grease-Purgeable

- Features:**
- **Direct Replacement for Pivot Joint O-Rings Using a 45° Chamfer Configuration**
 - **Primary Lip Offers a Superior Barrier of Contamination with an Engineered Secondary Lip that Controls Primary Lip Sealing Pressure**



+Split Option

- **Allows for Easy Replacement**

MATERIAL OPTIONS	
Standard Material -MDI Internally Lubricated Urethane	
Multiple Materials Available -Urethanes & Carbox Nitriles	
	P0103
Durometer	80
Tensile (PSI)	6820
Elongation (%)	680
MOD 100	580
MOD 300	2030

APPLICATIONS			
<input checked="" type="checkbox"/> Grease Purgeable	<input checked="" type="checkbox"/> Pivot Joints Med Speed Low Speed	<input checked="" type="checkbox"/> Contamination Exclusion	<input checked="" type="checkbox"/> Split <input checked="" type="checkbox"/> Solid

*Pivot Joint Testing

- 2 Head Tester
- Dust Contaminant
- Simulated Joint

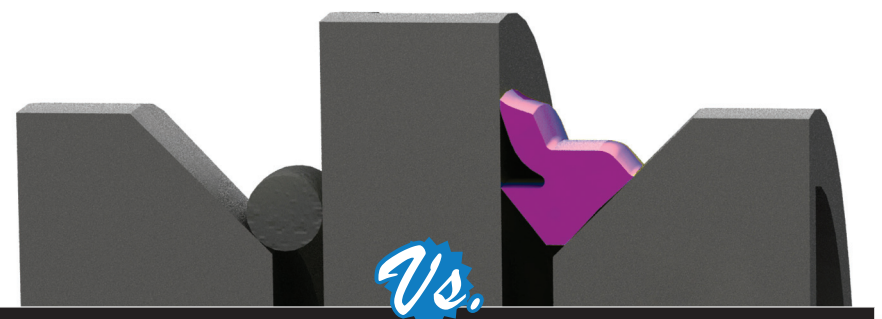

Parameters:	O-Ring NBR 70	MAD Seal
Degree of Rotation	200 CW / 200 CCW	200 CW / 200 CCW
Boss Chamfer Angle	45 deg	45 deg
Boss Chamfer ID	144 mm	144 mm
Joint Gap	2mm	2mm
Temperature	Ambient	Ambient
Lubricant ²	Lithium Grease Applied to Seal Face	Lithium Grease Applied to Seal Face
Test Cycle Duration	Until Failure	Until Failure
Medium	1 Part Each of Bentonite, Coarse, Medium and Fine ISO 12103 Test Dust (4 Parts Total)	
Cycle Frequency	0.344 Hz	0.344 Hz
Medium Level	Fully Submerged	Fully Submerged
Failure Criteria	Tablespoon of Contamination Present on the Bearing Side of Seal	
Mean Time to Failure (Hrs)	12.5	560
Component Cost*	\$30.50	\$4.01

*based on 560 hrs. of continuous use - (\$0.61 per o-ring X 50 uses)
Not including expense of new bearings, labor costs, and down time.