

# LIGHTWEIGHT ACCUMULATOR

**Standard diaphragm accumulators** effectively handle high pressures, but are typically heavy and their complex design increases manufacturing costs. Our new lightweight accumulators utilize a simplified design, light weight materials, and improved processes to provide a compact, economical accumulator option for certain applications

## VALUES FOR THE CUSTOMER

- Improvement of of function/cost ratio
- Reduction of weight
- Elimination of parts and process steps
- Elimination of the painting process
- Improvement of the filling process

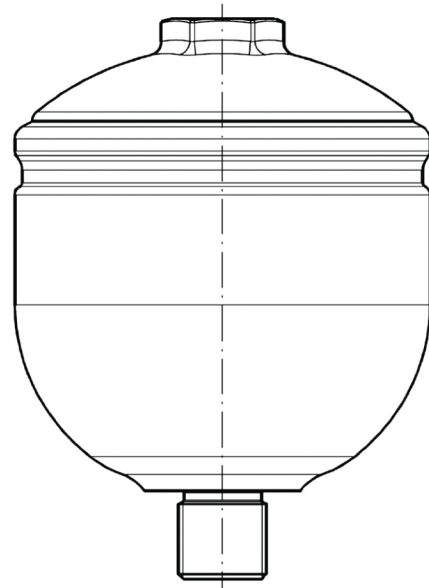

The information contained herein is believed to be reliable, but no representation, guarantees or warranties of any kind are made to its accuracy or suitability for any purpose. The information presented herein is based on laboratory testing and does not necessarily indicate end product performance. Full scale testing and end product performance are the responsibility of the user.

# LIGHTWEIGHT ALUMINIUM DIAPHRAGM ACCUMULATORS



Our hydraulic energy diaphragm accumulators are available in a variety of types for a wide range of applications. We offer a selection of accumulators that accommodate differences in nominal volumes, permissible operating pressures, gas pre-load, diaphragm materials, and fluid connections. Also, our aluminum diaphragm accumulators correspond to the European directive 2014/68/EU.

## Materials\*

Housing	Filling/Suggested Oil Type
Aluminum	Nitrogen/ Mineral oil of fluid group
Diaphragm Material	Permitted Operating Temperature
NBR	-20° C to +80° C
ECO	-40° C to +80° C

## Operating Conditions

Maximum Pressure	Gas Filling	Installation Position
80 bar	Pure nitrogen; the required gas filling must be specified when placing the order**	Optional, preferably vertical

## Dimensions

Volume [liters]	Height [mm]/Ø [mm]	Weight [kg]
0.16	h = 104 mm / Ø = 87 mm	0.5 kg
0.25	h = 116 mm / Ø = 97 mm	0.6 kg
0.32	h = 137 mm / Ø = 97 mm	0.8 kg
0.50	h = 147 mm / Ø = 110 mm	0.9 kg
0.75	h = 165 mm / Ø = 126 mm	1.3 kg

\*Different diaphragm materials available on request. The permitted working temperatures are dependent on the application limits of the metal materials (housing) and the diaphragm materials.

\*\*Catalog products do not contain a gas pre-charge. Please specify the gas fill pressure when placing the order.

Technical manual available on request.

## VALUES FOR THE CUSTOMER

- Light weight
- High corrosion resistance
- Long service life due to design and diaphragm durability
- Reduced cost of system (aluminium accumulators allow for less expensive system components)
- Reduced total system weight (aluminium accumulators and components weigh less than steel, etc.)

## Potential industrial and automotive applications include:

- Pilot circuits for agricultural and construction machinery
- Robotics
- Transmission control unit
- Brake systems

