

Shaft Seal Handbook





About ESP

ESP offers a suite of products and services that are critical to global OEMs.

ESP has developed in-house engineering that helps design OEM components such as seals, metal castings and forgings, and also provides value-added assembly, inventory management programs and supply chain logistics. After working with customers on design, ESP then uses its qualified domestic and global factories to find the best cost manufacturer of the component. ESP can then provide any necessary subassembly or add the components to a highly automated inventory management program.

ESP continues to increase the value added to our customers' bottom line with successfully implemented engineering services, assembly services, assembly fixtures, kitting, global supplier qualification, vendor optimization and the technology to efficiently manage a process from sourcing to manufacturing plant delivery.

Worldwide Presence

ESP has a global strategy with physical locations in China, India and Taiwan. We made the decision that the best way to participate in globalization was to follow our customers around the globe.



Industries Served

- Ag & Construction Equipment
- Fluid Power & Handling
- Power Sport Vehicles
- Powertrain Sealing Systems
- Lawn & Garden Equipment



Product Line

■ Product Line

■ RADIAL SHAFT SEALS

- Oil Seals
- Grease Seals
- Axial Face Seals
- Valve Stem Seals
- V-Rings

■ O-RINGS

- O-ring Kits
- Extruded Cord
- Spliced O-Rings – precision vulcanized
- X-Rings
- Square Rings
- Backup Rings

■ FLUID POWER PRODUCTS

- U-Cups in all styles and materials
- O-ring Loaded piston/rod seals in various materials
- Wear Rings
- Rod Wipers, Metal Encased and various materials
- T-Seals
- Piston Seals

■ CUSTOM MOLDED RUBBER & INJECTION MOLDING – ANY SHAPE AND MATERIAL, RUBBER TO METAL, ETC.

■ FASTENER AND THREAD SEALS



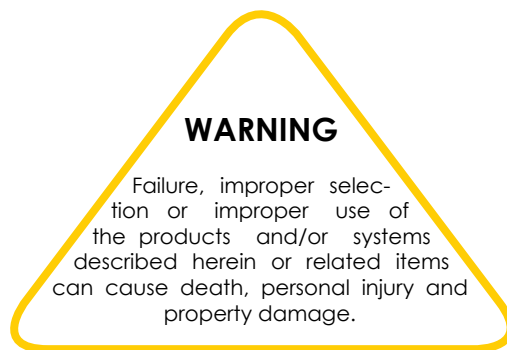

This document, along with product properties and operating parameters from ESP International are based upon industry standards or reported by others.

Please carefully evaluate your particular application. In any application for which there might be a risk of property damage or injury to persons, the final selection of a suitable product should be made by individuals possessing sufficient technical skills and competence. Only a trained professional should make the final product selection.

It is important that you analyze all aspects of your application and review the information concerning the product or system. Due to the variety of operating conditions and application for these products, the user through his or her own analysis and testing, is solely responsible for making the final product definition and assuring that all performance, safety and warning requirements of the application are met. The information in this document is subject to change by ESP International and its subsidiaries at any time without notice.

Table of Contents

	Page
■ Introduction	5
■ Materials	7
■ Seal Design	33
■ Profiles	81
■ Manufacturing Process	103
■ Installation	111
■ Applications	121
■ Custom Seal Testing	129
■ Troubleshooting	137
■ Order Information	177
■ Reference	181

THE EVOLUTION OF RADIAL SHAFT SEALS

For centuries engineers have been faced with the challenge of effectively sealing against dynamic surfaces. In the frontier era, as people began to migrate west across great distances, the need for a sealing system that could extend the life of wagon wheels became a necessity. The first known shaft seals were leather straps used to retain animal fat on the end of a wheel axle. This crude method of sealing often leaked and required routine maintenance.

The Industrial Revolution spawned the development of internal combustion engines, transmissions and gearboxes. All of these systems had challenging sealing requirements.

The seals of the industrial age were organic ropes or packings. These seals proved to be very effective until shaft speeds, temperatures and other parameters increased with the development of better transportation systems.

In the late 1920's, a self contained shaft seal was created from oil resistant leather assembled into a metal case. This was the first radial lip seal to be press fit into an outside diameter (OD) bore.

The most significant development in the evolution of the radial lip seal happened toward the end of World War II. A synthetic oil-resistant rubber, known as nitrile, replaced the leather element, forever changing seal design. Methods for bonding rubber to metal soon followed and, by the 1950's, direct bonded seals were readily available.

In the 1960's high temperature elastomers were developed including: silicone, polyacrylate and fluorocarbon. The increased price of these materials encouraged manufacturers to reduce material volume to stay cost effective. The resulting seal of the 1970's remains one of the most common designs today.

The 1980's brought an important change in radial lip seal design. The dynamic sealing surface was incorporated into the seal assembly. Doing this created a series of lips with horizontal as well as vertical contact points. This integral system was a technological advance that allowed manufacturers to take responsibility for the entire sealing system and not just the seal. This allowed them to provide a value added package, not just a commodity.

The future of radial shaft seals will be centered around the relationship between customer and manufacturer. The advancement of machinery design will depend on these relationships; the first to be successful will lead the next phase in seal evolution.

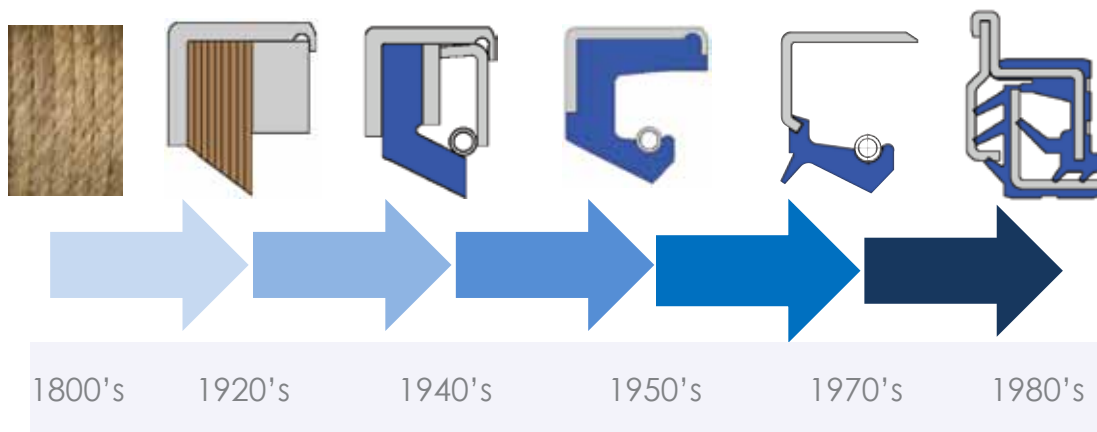

Radial Shaft Seal Evolution

The first known shaft seals were leather straps used to retain animal fat on the end of a wheel axle.

MATERIALS

ELASTOMERS

Elastomers are polymers that have the ability to recover within 10% of their original length after being stretched 100% for five minutes.

A polymer is a macromolecule consisting of a repeated chain of smaller units. Based on their behavior when exposed to heat, polymers can be divided into two categories, thermoplastics and thermosets.

The macromolecules in thermoplastics are entangled and not interconnected. They can be melted and reformed without significant impact to mechanical properties. Thermoplastics have good ductility and formability.

The macromolecules in thermosets are closely intertwined and are interconnected. Thermosets undergo chemical cross-linking during hardening that is irreversible. This prevents them from being remolded or recycled.

Elastomers are commonly referred to as either natural or synthetic rubber. Natural rubber comes from latex, a milky colloid produced by some trees (especially trees of the genera *Hevea* and *Ficus*). To harvest the latex a diagonal incision is made in the bark of the tree, the latex begins to flow through the incision and is collected in buckets at the base of the tree.

All of the elastomers discussed here are synthetic rubbers which are compounds comprised of several constituents. These elastomers are a mix of a base polymer and other chemicals that are used to improve mechanical properties through a vulcanization process.

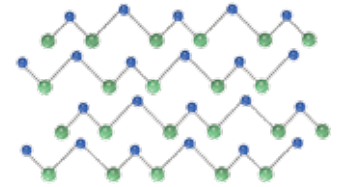

Thermoplastics.

Macromolecules in thermoplastics are entangled and not interconnected.

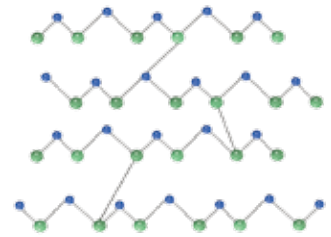

Thermoset.

Macromolecules in thermoset are closely intertwined and are interconnected.



Natural rubber.

Comes from latex, a milky colloid produced by some trees.

Vulcanization is a chemical process induced by heating rubber with vulcanizing agent (such as sulfur). Vulcanized rubber has higher tensile strength and is more resistant to swelling and abrasion. A typical elastomer compound may be composed of the following elements:

- **Base polymer:** Can be natural rubber or synthetic polymers. Natural rubber has a higher tensile strength and resistance to fatigue, while synthetic rubber offers better resistance to abrasion, heat and the effects of aging.
- **Fillers:** Fillers are used for two main reasons, to improve the mechanical properties of the material (such as tear strength, tensile strength, abrasion resistance and modulus of elasticity) or to reduce cost. Carbon black and silica are the most common reinforcing fillers. Carbon black provides better modulus and resistance to abrasion than colloidal silica. The smaller the particle size, the greater the observed reinforcing effect.
- **Plasticizers:** Plasticizers improve the flow of the rubber during processing and improve the low temperature properties of the vulcanizate. The most common plasticizers are esters, pine tars and low molecular weight polyethylene.
- **Vulcanizing agents:** The most common vulcanizing agent is sulfur, but peroxides, urethane crosslinkers, metallic oxides and acetoxysilane are also used.
- **Accelerators:** Accelerators increase the rate of the cross linking reaction and cross linking density, without affecting the properties of the elastomer. The effect of a combination of accelerators is stronger than the added effects of the individual components.

- Cure activators: are used to start vulcanization and promote crosslinking and cure. The two most common activators are zinc oxide and stearic acid.
- Inhibitors: When the temperature increases the reaction rate increases as well, inhibitors are added to force a slower chemical reaction during the vulcanization process.
- Anti-degradants: Anti-degradants increase resistance to the environment. Common anti-degradants include antioxidants and antiozonants which help the elastomer resist degradation from ozone, UV light and oxygen.
- Pigments: Pigments, organic and inorganic, are used to color the material.

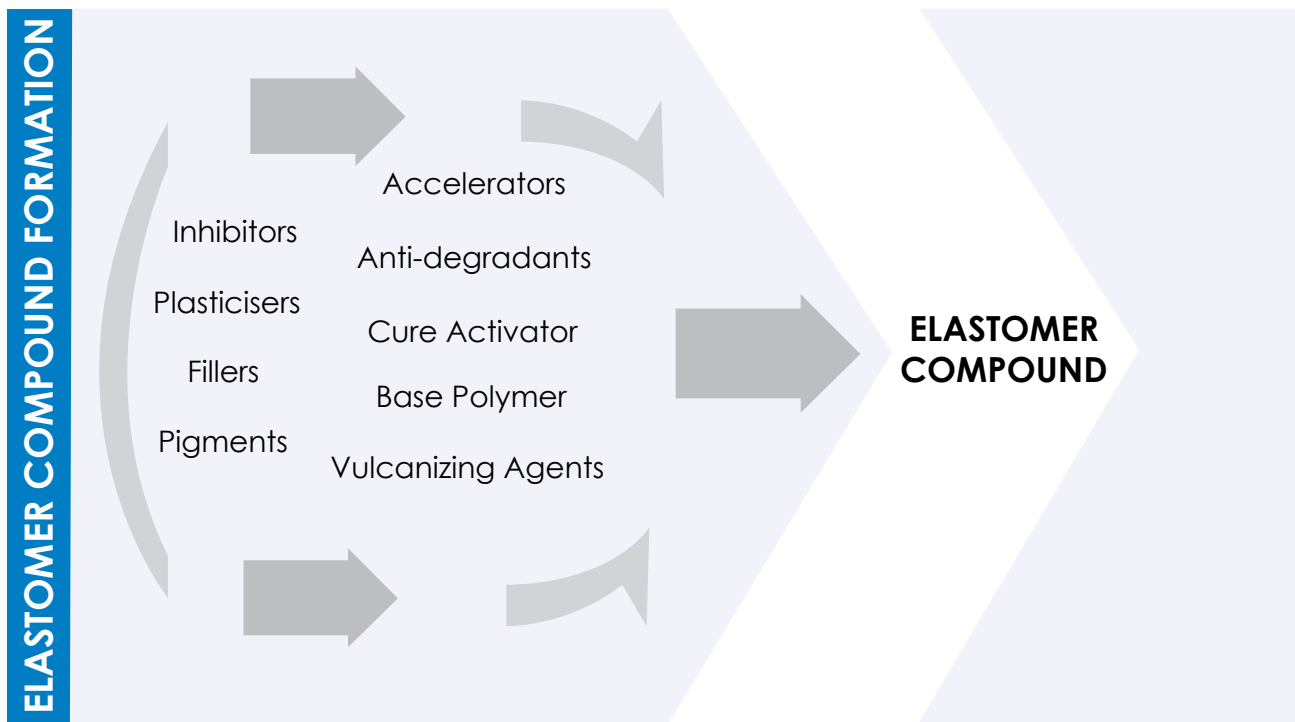

Elastomer Compound.

A typical elastomer compound may be composed of these elements.

THE EVOLUTION OF RUBBER

- In 1731 Charles Marie de La Condamine, a French geographer and mathematician, set out on an expedition to South America. In 1736 while in route to Quito, Ecuador La Condamine became the first westerner to encounter rubber. He also coined the term “latex”.
- In 1770 Joseph Priestley discovered that rubbing the material over pencil marks on paper would erase them, and thus originated the name “rubber”.
- In 1791 Samuel Peal patented a method that made fabric waterproof by treating it with rubber.
- In 1823 Charles Macintosh founded a factory that made rainproof cloth and fabrics using rubber.
- In 1834 Friedrich Ludersdorf and Nathaniel Hayward discover that adding sulfur to the rubber made it less sticky.
- In 1839 Charles Goodyear discovered that adding sulfur to rubber and then heating it made it retain its elasticity, this process is known today as vulcanization.
- In 1860 Charles Hanson Greville Williams discovered that natural rubber was an isoprene monomer, this was a fundamental discovery for the development of synthetic rubber years later.
- In 1877 Chapman Mitchell started working with sulfuric acid to recycle rubber into new products.
- In 1905 Arthur H. Marks invented the alkaline recovery process, and the first rubber factory laboratory was founded.
- In 1906 George Oenslager discovered that adding accelerators to the vulcanization process would reduce the heating time for curing by 60 – 80%, improving the properties of the rubber.
- In 1926 German scientist G. Ebert succeeded in producing a sodium-polymerized rubber from butadiene that would become the predecessor to nitrile.

- During World War II the supply of natural rubber was greatly depleted, this accelerated the development of synthetic rubber leading to many of the compounds used today.

With the development of synthetic rubbers the mechanical properties of the materials could be significantly improved. Today the use of synthetic rubber in industry is common place and can be found in many products such as radial shaft seals.

MATERIAL PROPERTIES

Elastomers are a versatile product used in a wide range of applications. When selecting a compound there are a number of physical properties that should to be considered:

- **Hardness:** The measure of a material's resistance to deformation by surface indentation. The typical measuring system for elastomers is the Shore durometer. The A scale is used for soft elastomers, while the D scale is used for harder elastomers. The ASTM specification for the durometer hardness test method for rubber is ASTM D2240.
- **Tensile strength:** The amount of force required to fracture a rubber specimen while applying tensile force along it. In the metric system it is measured in MPa (megapascals) and in the English System it is measured in psi (pounds-per-square-inch). The ASTM specification for tension test methods for vulcanized rubber and thermoplastic elastomers is ASTM D412.



Hardness Tester.

Measure of a material's resistance to deformation by surface indentation.



Tensile Strength Machine.

Amount of force required to fracture a rubber specimen while applying tensile force along it.



Tear Resistance Tester.

The capacity of a material to resist the growth of a cut when tension is applied.



Abrasion Resistance Tester.

Amount of material lost due to wear by the contact of a moving part.

- **Elongation:** The percentage that the rubber specimen will deform before braking when a tensile force is applied.
- **Modulus:** is the stress required to produce a given force. Higher modulus = less extrusion. It is measured in MPa.
- **Tear resistance:** Is the capacity of a material to resist the growth of a cut when tension is applied. It is measured in kN/m (kilonewtons per meter) for the metric system or in lbf/in (pounds force per inch) for the English system. The ASTM specification for tear strength of conventional vulcanized rubber and thermoplastic elastomers is ASTM D624.
- **Abrasion resistance:** Is the amount of material lost due to wear by the contact of a moving part.
- **Flexibility:** The resistance of the material to a bending force without being damaged.
- **Adhesion:** Ability of the material to cling to the metallic case. The ASTM test method for adhesion to rigid substrates is ASTM D429.
- **Compression set resistance:** The percentage of the original specimen thickness after axially directed pushing forces are applied and released over a set temperature and time. The ASTM specification for compression set is ASTM D395.

- Resilience: The ability to absorb temporary energy without creating a permanent distortion. The ASTM specification for resilience is ASTM D945.

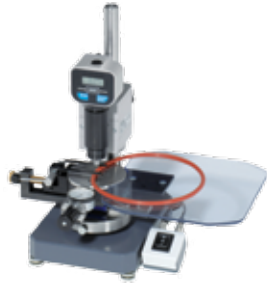

Compression Set Tester.

Percentage of the original specimen thickness after axially directed pushing forces are applied.



Resilience Tester.

Ability to absorb temporary energy without creating a permanent distortion.

MATERIALS PROFILES

Selecting the elastomer material for a radial shaft seal is important because it has to ensure that it satisfies all of the requirements for the application, without increasing the cost.

There are different materials that are used to make radial shaft seals the most common materials used by ESP International are the following:

- Nitrile (N)
- Hydrogenated Nitrile (H)
- Fluoroelastomer (F)
- Polyacrylate (P)
- Silicone (S)
- Polytetrafluoroethylene (PTFE)
- Ethylene Propylene Diene Monomer (E)
- Chloroprene (C)
- Polyurethane (AU)



Temperature Range.

Temperature range of Nitrile

NITRILE

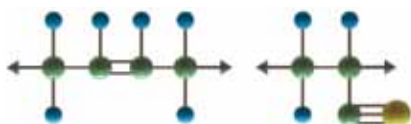
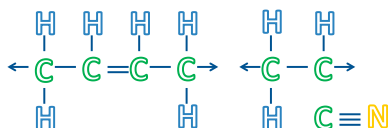

Molecular Structure of Nitrile.

Nitrile is the combination of butadiene and acrylonitrile.

NITRILE or BUNA N or NBR

Low cost, temperature range -40° to +250° F, most commonly used elastomer. Shelf life 3 to 5 years

ASTM D2000/ SAE J200 Type/Class – BF, BG, BK or CH classifications.

ASTM D1418 Designation NBR, XNBR

ARP 5316 Shelf life 15 Years

Nitrile is the combination of butadiene (provides elasticity and low temperature flexibility, creates resistance to heat, chemicals and oxidation) and acrylonitrile (provides hardness, tensile strength and creates resistance to abrasion, fuel and oil). A standard general-purpose nitrile compound usually contains 34% ACN (Acrylonitrile).

ACN ranges from 18% to 50%. While incrementing the ACN content, the high temperature properties improve but it also affects the low temperature properties.

Advantages: Excellent tensile strength, abrasion, tear and compression resistance. It is used in water and steam applications (below 212° F), petroleum oils and fuels, silicone oils and greases, propane, ethylene glycol, butane, vegetable, mineral oils and greases, dilute acids.

Disadvantages: Low resistance to ozone, sunlight and weathering. Incompatible with benzene, toluene, xylene, halogen derivatives (carbon tetrachloride, trichloroethylene), ketones (MEK, acetone), phosphate ester hydraulic fluids (Skydrol, Pydraul), strong acids, glycol.

HYDROGENATED NITRILE or HNBR or HYDROGENATED NITRILE BUTADIENE RUBBER

High cost, temperature range -25° to +300°F

ASTM D2000/ SAE J200 Type/Class DH

ASTM D1418 Designation None

MIL-HDBK-695 Shelf life 15 Years

Hydrogenated Nitrile comes from adding hydrogen to the nitrile molecular chain to make it more stable. The addition of hydrogen reduces the number of carbon-carbon double bonds, making it less reactive.

Advantages: In comparison with NBR, HNBR has better abrasion resistance, tear resistance, high temperature properties and resistance to chemical attacks. It can be used in ozone applications, R134a refrigerant gas, petroleum oils and fuels, water and steam (up to 300° F), silicone oils and greases, vegetable and animal fats and fluids.

Disadvantages: Cannot be use in chlorinated hydrocarbons, polar solvents (esters and ketones), and strong acids.



Temperature Range.

Temperature range of Hydrogenated Nitrile

HYDROGENATED NITRILE

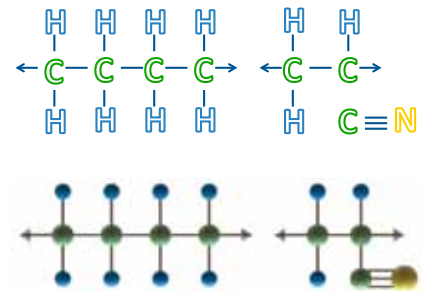

Molecular Structure of Hydrogenate Nitrile.

The addition of hydrogen reduces the number of carbon-carbon double bonds, making it less reactive.



Temperature Range.

Temperature range of Polyacrylate.

POLYACRYLATE

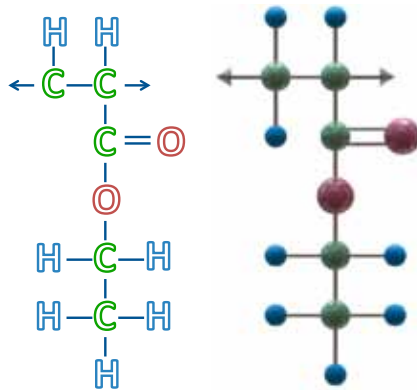

Molecular Structure of Polyacrylate.

Are copolymers of ethyl or butyl acrylate with a combination of chlorine, acid, amide or epoxy compounds.

POLYACRYLATE or ACM

Medium cost, temperature -25° to +275°F

ASTM D2000/ SAE J200 Type/Class – DF, DH or EH

ASTM D1418 Designation ACM

MIL-HDBK-695 Shelf life 20 Years

Polyacrylate are copolymers of ethyl or butyl acrylate with a combination of chlorine, acid, amide or epoxy compounds.

Advantages: Resistance to petroleum fuels and oils, automatic transmission fluid, type A power steering fluid. Good resistance to mineral oil, sunlight, oxygen and ozone.

Disadvantages: Cannot be used in alcohol, alkalis, glycol based brake fluids, EP fluids, chlorinated hydrocarbons, gear oils, glycol based brake fluids, hydrocarbons, water or steam (above 275°F), acids and amines. Lower water compatibility, cold flexibility, strength and compression set resistance than nitrile.

FLUOROELASTOMER or FLUOROCARBON or FKM or VITON®

High cost, temperature -15° to +400°F

ASTM D2000/ SAE J200 Type/Class HK

ASTM D1418 Designation FKM

ARP 5316 Shelf life Unlimited

Fluorine is added to thermoset elastomers creating Fluoroelastomers. It's generally composed of vinylidene fluoride (VF2), hexafluoropropylene (HFP), containing 66% – 70% fluorine. And other components are added to improve different properties, like tetrafluoroethylene, which offers better chemical resistance and perfluoromethylvinyl ether (PMVE) which improves FKM's low temperature properties.

Advantages: Excellent resistance to chemicals, oil, ozone and sunlight. Can be used in petroleum oils and fuel, non flammable hydraulic fuels, acids, aircraft engine applications, synthetic hydraulic fluids, organic solvents, mineral and vegetable oil and grease, aliphatic hydrocarbons (butane, propane, natural gas), hard vacuum applications, silicone oils and greases, solvents and water or steam (up to 400°F).

Disadvantages: Cannot be used in amines, glycol based brake fluids, methanol, ammonia gas, amines, alkalis, hydrocarbons, ketones, low molecular weight esters and ethers, fireproof hydraulic fluids, formic and acetic acids.



Temperature Range.

Temperature range of
Fluorocarbon

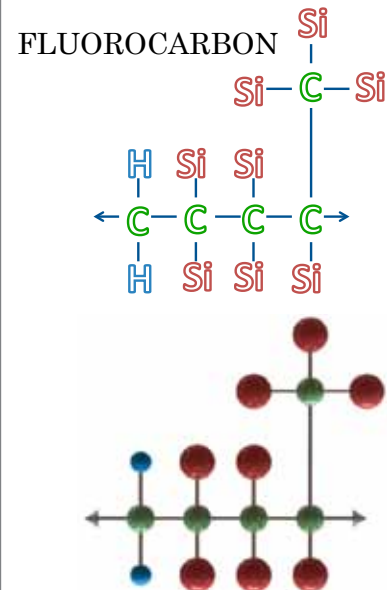

Molecular Structure of
Fluorocarbon.

Fluorine is added to
thermoset elastomers
creating the
Fluoroelastomers family.



Temperature Range.

Temperature range of Polytetrafluoroethylene.

POLYTETRAFLUOROETHYLENE



Molecular Structure of Polytetrafluoroethylene

Polytetrafluoroethylene (PTFE) is commonly known as Teflon.

POLYTETRAFLUOROETHYLENE or FEP or PTFE or TEFLON

High cost, temperature -65° to 325°F

ASTM D2000/ SAE J200 Type/Class

ASTM D1418 Designation FEP

Shelf life Unlimited

Polytetrafluoroethylene, also commonly known as Teflon®, is known for its non-reactive characteristic. The strength between the bonds of carbon and fluorine gives the material this non-reactive characteristic. It is widely used in a lot of industries because it has one of the lowest coefficients of friction against any solid.

Advantages: Great chemical resistance. Can be used in petroleum oils and fuels, ozone, chemical applications, solvents (MEK, acetone, xylene), and weather. It is used in high speed and pressure applications; and in applications where lubricants cannot be used. Known for it's low friction properties.

Disadvantages: Cannot be used in fluorine greases and oils, chlorine trifluoride, and molten alkali metal solutions. It doesn't seal well when the surface of the rod is rough or vibrates.

SILICONE or VMQ or Q

Medium cost, temperature -65° to +300°F

ASTM D2000/ SAE J200 Type/Class – FC, FE or GE

ASTM D1418 Designation MQ, PMQ, VMQ

ARP 5316 Shelf life Unlimited

Silicones are elastomers made from silicone, oxygen, hydrogen and carbon. Silicones are used in the medical and food industry because they do not have any odor or taste.

Advantages: Resistant to oxygen, ozone, UV light, mineral and vegetable oils, diluted salt solutions, engine and transmission oil, brake fluids (non petroleum base), fire resistant hydraulic fluid, high molecular weight chlorinated aromatic hydrocarbons. Good flexibility and compression set.

Disadvantages: Cannot be used in acids, EP fluids, fuels, gear oils, ketones and benzene. Should not be used in dynamic applications due to it's low tensile strength, poor wear and tear strength.



Temperature Range.

Temperature range of Silicone.

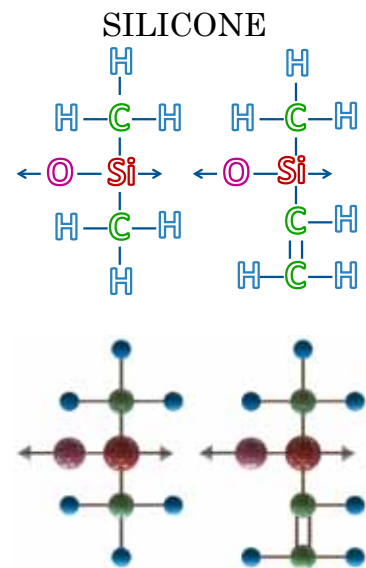

Molecular Structure of Silicone.

Are elastomers made from silicone, oxygen, hydrogen and carbon.



Temperature Range.
 Temperature range of Chloroprene Rubber.

CHLOROPRENE RUBBER or CR or Neoprene®

Temperature -40° to 250°F

ASTM D2000/J200 Type/Class BC, BE

ASTM D1418 Designation CR

ARP 5316 Shelf life 15 Years

Chloroprene is the first synthetic rubber developed commercially and exhibits generally good ozone, aging and chemical resistance. It has good mechanical properties over a wide temperature range.

Advantages: Can be use in paraffin base mineral oil with low DPI, silicone oil and grease, water and water solvents (up to 250°F), refrigerants, ammonia and carbon dioxide.

Disadvantages: Cannot be used with aromatic hydrocarbons, chlorinated hydrocarbons, ketones, esters and ethers.

CHLOROPRENE

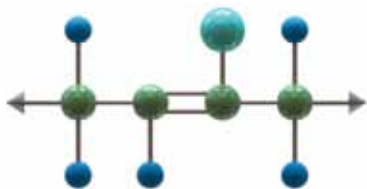
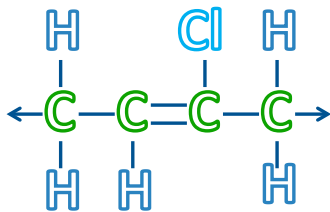

Molecular Structure of Chloroprene
 First synthetic rubber developed commercially.

EPDM or ETHYLENE PROPYLENE DIENE MONOMER

Temperature -70° to 302°F

ASTM D2000/J200 Type/Class AA, BA, CA, DA

ASTM D1418 Designation EPDM

ARP 5316 Shelf life Unlimited

Ethylene propylene diene monomer is also known as EPDM, the E stands for ethylene, P for propylene, D for Diene and M for monomer. The ethylene content is typically around 45% to 75% for the EPDM.

Advantages: Can be used in water and steam (up to 300°F), glycol based brake fluids, silicone-based break fluids, many organic and inorganic acids, cleaning agents, sodium and potassium alkalis, phosphate-ester based hydraulic fluids, silicone oil and grease, alcohols, ketones, esters and ozone.

Disadvantages: Cannot be used with mineral oil products like oils, greases and fuels.



Temperature Range.

Temperature range of Ethylene Propylene Diene Monomer.

EPDM

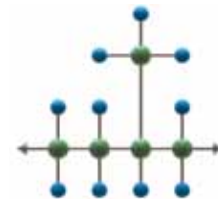
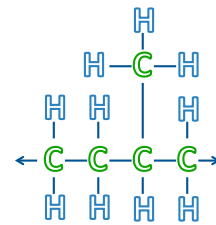

Molecular Structure of Ethylene Propylene Diene Monomer

The E stands for ethylene, P for propylene, D for diene and M for monomer.



Temperature Range.

Temperature range of Polyurethane.

POLYURETHANE

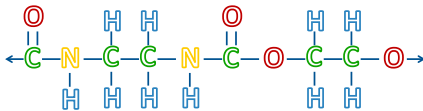

Molecular Structure of Polyurethane

The essential components of Polyurethane are isocyanate and polyol.

POLYURETHANE or AU or EU

Temperature -40°F to 180°F

ASTM D2000 /J200 Type/Class BG

ASTM D1418 Designation AU, EU

ARP 5316 Shelf life 5 Years

Polyurethanes are produced by the polyaddition reaction of a polyisocyanate with a polyol in the presence of a catalyst.

Advantages: Good wear resistance, high tensile strength, tear strength, extrusion resistance and elasticity. Can be used with propane, butane, mineral oil and grease, silicone oil and grease.

Disadvantages: Cannot be used with ketones, esters, ethers, alcohols, glycols, steam, alkalis, amines, acids. Water resistant capable but only up to 125°F.

CASE MATERIALS

The material of the metal case can be carbon steel or stainless steel depending on the customer's requirements. Other materials such as aluminum and brass are available but seldom used due to their additional cost.

Some factors that determine the material of the case are the bore material, the fluid that it's used and the environment that the case is exposed to.

CARBON STEEL

According to The American Iron and Steel Institute carbon steel is defined as having no more than 2% carbon and no other appreciable alloying elements. In seal constructions it is used as a general purpose case material.

There are many grades of steel available but for seal case construction low carbon steel is extensively used. Low carbon steel generally has 0.04% - 0.15% carbon content. It is also known as mild steel and has a low tensile strength and is well suited for installing into metal bores.

CARBON STEEL	
Low Carbon	0.04% - 0.15%
Medium Steel	0.3% - 0.6%
High Carbon	More than 0.6%

STAINLESS STEEL

Used for its corrosion resistance properties, it is non-magnetic and contains sufficient chromium to form a passive film of chromium oxide, which prevents further surface corrosion and blocks corrosion from spreading into the metal's internal structure. The FDA requires that the seals being used in drug and food preparation have a stainless steel case.



Metal Case.

The material of the case can be carbon steel or stainless.

SPRING MATERIAL

The spring of the seal is made of mid-high carbon steel or spring steel which contains 0.6 to 0.9% carbon. This material is known to have very high yield strength which allows the material to return back to it's original shape after significant bending or twisting.

Stainless steel is a second choice for spring material and can be used in high temperature applications or in corrosive environments.

The FDA also requires that for seals used in food and drug preparation the spring must be a stainless steel material.



Garter Spring.

Commonly high carbon spring steel.

ASTM D 2000

MATERIALS

The American Society of Testing and Materials established the ASTM D 2000/ SAE J200 the "Standard Classification System for Rubber Products in Automotive Applications".

This classification is used to ensure that besides the different compounds manufacturers are using, the quality and performance of the material is consistent.

This line call-out contains the following:

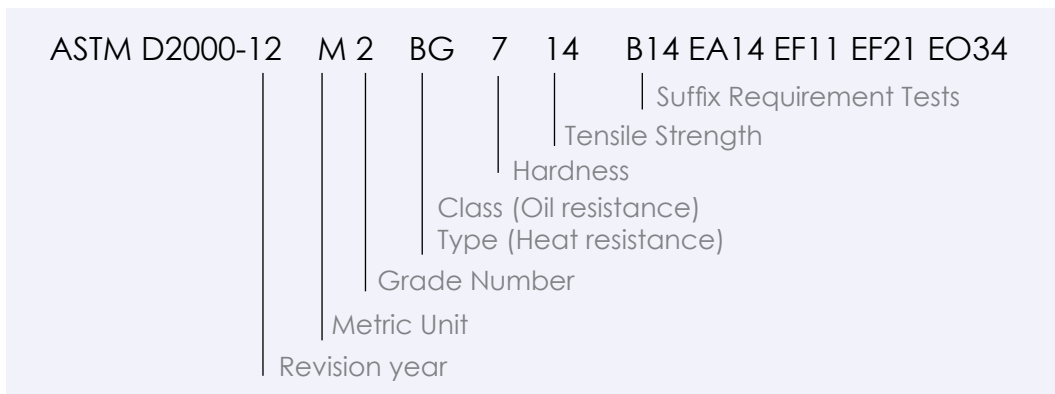

- The document name. The two digit number following ASTM indicates the revision year.

ASTM D2000-**12** M2 BG 7 14 B14 EA14 EF11 EF21 EO34

Revision Year

- The letter M indicates units are SI, when it's not present the units are in English units.

ASTM D2000 **M**2 BG 7 14 B14 EA14 EF11 EF21 EO34

Metric Unit

MATERIALS

- The Grade Number defines specific added test requirements in cases where the basic requirements do not always sufficiently ensure an acceptable material. A grade of 1 indicates that only the basic requirements need to be met. A grade of 2 or above indicate additional tests are required for the material.

ASTM D2000 M **2** BG 7 14 B14 EA14 EF11 EF21 EO34
Grade Number

- The Type indicates the heat resistance properties of the elastomer.

ASTM D2000 M 2 **B**G 7 14 B14 EA14 EF11 EF21 EO34
Type

TYPE	TEST TEMPERATURE	
	°C	°F
A	70	158
B	100	212
C	125	257
D	150	302
E	175	347
F	200	392
G	225	437
H	250	482
J	275	527
K	300	572

MATERIALS

- The class indicates the swell resistance properties of the elastomer as measured by volume swell under test procedures.

ASTM D2000 M2 **G** 7 14 B14 EA14 EF11 EF21 EO34
Class

CLASS	VOLUME SWELL (Maximum %)
A	No requirement
B	140
C	120
D	100
E	80
F	60
G	40
H	30
J	20
K	10

The table below has the most common polymers used for type and class:

AA	Natural rubber, re-claimed rubber, SBR, butyl, EP, polybutadiene, polysoprene	DE	CM (Chlorine), CSM (Chlorosulfonyl)
AK	Polysulphides	DF	Polyacrylate (butyl-acrylate type)
BA	Ethylene propylene, high temperature SBR, butyl compounds	DH	Polyacrylate polymers, HNBR
BC	Chloroprene polymers (neoprene), CM	EE	AEM, ethylene acrylic, (Vamac®)
BE	Chloroprene polymers (neoprene), CM	EF	Ethylene acrylic, Vamac®
BF	Nitrile	EH	ACM (polyacrylate)
BG	Nitrile, urethanes	EK	Float zone silicone (FZ)
BK	Nitrile	FC	Silicone (high strength)
CA	Ethylene propylene	FE	Silicones
CE	Chlorosulfonated polyethylene (Hypalon®), CM (Chlorine)	FK	Fluorosilicone
CH	Nitrile, epichlorohydrin polymer (Hydrin®)	GE	Silicones
DA	Ethylene propylene polymers	HK	Fluoroelastomers (Viton®, Fluorel)
		KK	Perfluoroelastomers

- The next digit is the hardness of the elastomer, measured in the Shore A durometer.

ASTM D2000 M2 BG **7** 14 B14 EA14 EF11 EF21 EO34

Grade Number

- The next two digits indicate the minimum tensile strength. If it's in the metric units it will be in MPa (megapascals); and if it's in the English unit it's in ksi (kilopounds-per-square inch).

ASTM D2000 M2 BG 7 **14** B14 EA14 EF11 EF21 EO34

Tensile Strength

- Suffix requirement tests: the letters and numbers after the tensile strength indicates the additional test that are required. The letter indicates the test, the first digit indicates the test method and the second digit indicates the temperature. The tests required vary depending on the first digit after the suffix letter.

ASTM D2000 M2 BG 7 14 **B14 EA14 EF11 EF21 EO34**

Suffix Requirement Test

MATERIALS

- The table below shows the various tests required, with the first suffix letter listed down the side and the first suffix number listed across the top.

Basic Requirements and First Suffix No. Requirement or Suffix Letter	Basic	1	2	3	4	5	6	7	8	9
Tensile Strength, Elongation	D412, die C	-	-	-	-	-	-	-	-	-
Durometer Hardness, Type A	D2240	-	-	-	-	-	-	-	-	-
Suffix A, Heat Resistance	-	D573,70h	D865,70h	D865,168h	D573,1000h	D865,1000h	-	-	-	-
Suffix B, Compression Set, Standard Test Specimen Cut from a Slab	-	D395,22h, Method B, solid	D395,70h, Method B, solid	D395,22h, Method B, plied	D395,70h, Method B, plied	D395,1000h, Method B, solid	D395,1000h, Method B, plied	-	-	-
Suffix C, Ozone or Weather Resistance	-	D1171, ozone exposure, Method A	D1171, weather	D1171, ozone exposure, Method B	-	-	-	-	-	-
Suffix D, Compression-Deflection Resistance	-	D575, Method A	D575, Method B	-	-	-	-	-	-	-
Suffix EO, Oil Resistance	-	D471, ASTM Oil No. 1, 70h	D471, ASTM Oil No. 2, 70h	D471, ASTM Oil No. 3, 70h	D471, ASTM Oil No.1, 168h	D471, ASTM Oil No.2 168h	D471, ASTM Oil No. 3, 168h	D471, Service Fluid No. 101, 70h	D471, Oil as specified with ASTM	-
Suffix EF, Fluid Resistance	-	D471, Reference Fuel A, 70h	D471, Reference Fuel B, 70h	D471, Reference Fuel C, 70h	D471, Reference Fuel D, 70h	D471 Volume Percent Reference Fuel D Plus 15 Volume Percent Denatured Ethanol, 70h	-	-	-	-

MATERIALS

Basic Requirements and First Suffix No. Requirement or Suffix Letter	Basic	1	2	3	4	5	6	7	8	9
Suffix EA, Aqueous Fluid Resistance	-	D471, Distilled Water, 70h	D471, Equal Parts by Volume Distilled Water-Reagent Grade Ethylene Glycol, 70h	-	-	-	-	-	-	-
Suffix F, Low-Temperature Resistance	-	D2137, Method A, 9.3.2, 3 min	D1053, 5min, T_2 T_5 T_{10} T_{50} Or T_{100}	D2137, Method A 9.3.2, 22h	-	-	-	-	-	-
Suffix G, Tear Resistance	-	D624, die B	D624, die C	-	-	-	-	-	-	-
Suffix H, Flex Resistance	-	D430, Method A	D430, Method B	D430, Method C	-	-	-	-	-	-
Suffix J, Abrasion Resistance	-	-	-	-	-	-	-	-	-	-
Suffix K, Adhesion	-	D429, Method A	D429, Method B	Bond made after vulcanization	-	-	-	-	-	-
Suffix M, Flammability Resistance	-	-	-	-	-	-	-	-	-	-
Suffix N, Impact Resistance	-	-	-	-	-	-	-	-	-	-
Suffix P, Staining Resistance	-	D925, Method A	D925, Method B Control Panel	-	-	-	-	-	-	-
Suffix R, Resilience	-	D945	-	-	-	-	-	-	-	-
Suffix Z, Special Requirement	-	-	-	-	-	-	-	-	-	-

- Lastly, the second suffix number indicates the test temperature required.

ASTM D2000 M2 BG 7 14 **B14 EA14 EF11 EF21 EO34**

Suffix Requirement Test

Suffix Letters A, B, C, EA/F/O, G, K, L	
1	73° F / 23° C
2	100° F/38° C
3	158° F/70° C
4	212° F/100° C
5	257° F/125° C
6	302° F/150° C
7	347° F/175° C
8	392° F/200° C
9	437° F/225° C
10	482° F/250° C
11	527° F/275° C

Suffix Letters F	
1	73.4° F/23° C
2	32° F/0° C
3	14° F/-10° C
4	-0.4° F/-18° C
5	-13° F/-25° C
6	-31° F/-35° C
7	-40° F/-40° C
8	-58° F/-50° C
9	-67° F/-55° C
10	-85° F/-65° C
11	-103° F/-75° C
12	-112° F/-80° C

IMPORTANCE OF EDUCATION

Understanding how a radial shaft seal performs in an application creates an invaluable awareness of the entire sealing system. Knowing what physical principals are at work, a design engineer is more likely to be thinking about seal selection earlier in the design process.

The life cycle of mobile machinery can be limited by the effectiveness of the radial shaft seal. When failure occurs, the seals are believed to be at fault. But in fact, the root cause of failure is usually unknown and lies buried in the network of sealing parameters. Not understanding these parameters can be detrimental to the life of a seal. If the design engineer does not know how shaft preparation affects the sealing mechanism, then lead, which is spiral grooves on the shaft surface, is more likely to occur. By understanding how different parameters affect the sealing mechanism, the correct profile is more likely to be selected and the system variables controlled.

ESP International understands the importance of education and recognizes the need in our market for a technical presence. The intentions of this handbook are to provide a resource for engineers that organize the industry standards for radial shaft seals. In the design process, engineers may not have time to research all of the operation details of each part.

Often seal selection is compromised and the chance of failure increases. This handbook will reduce the research time without losing education. Radial shaft seals are designed and selected based on profile characteristics.

SEAL THEORY

The challenge of sealing against a dynamic surface has been around since the frontier era. The first known shaft seals were leather straps used to retain animal fat on the end of a wheel axle. This crude seal required routine maintenance and was unreliable. The Industrial Revolution spawned the development of engines, transmissions and gearboxes, all of which required various seals to retain a variety of lubricants. The seals of the industrial age were organic ropes or packing. These seals were very effective until shaft speeds, temperature and other parameters increased with the development of better transportation systems.

In the late 1920's, a self contained shaft seal was created from oil resistant leather assembled into a metal case. This was the first radial lip seal to be press fit into an outside diameter bore. Radial shaft seals continued to develop further and a synthetic, oil-resistant rubber replaced the leather element, forever changing seal design.

HOW DO THEY WORK?

Radial shaft seals prevent leakage through the generation of a pumping action at the interface of the seal lip and the shaft surface. The pumping direction has a direct correlation to the direction of an asymmetrical contact pressure profile. This pressure profile is controlled by the geometric design of the lip seal which is designed to create a larger pressure gradient on the oil side of the sealing lip. The pressure gradient is one aspect that contributes to the function of a radial shaft lip seal.

A second aspect that contributes to the pumping mechanism of a seal lip is the presence of an oil film layer between the seal lip surface and the shaft surface.

The third aspect in the sealing mechanism that contributes to the net pumping effect is the formation of asperities on the seal lip surface. The asperities become aligned at an angle to the rotating shaft causing the oil film to pump towards the oil side of the seal.

The existence of the asymmetric pressure profile, fluid film and asperities all contribute to the pumping mechanism of the seal. Seal failure occurs over a period of time and can be attributed to many different effects.

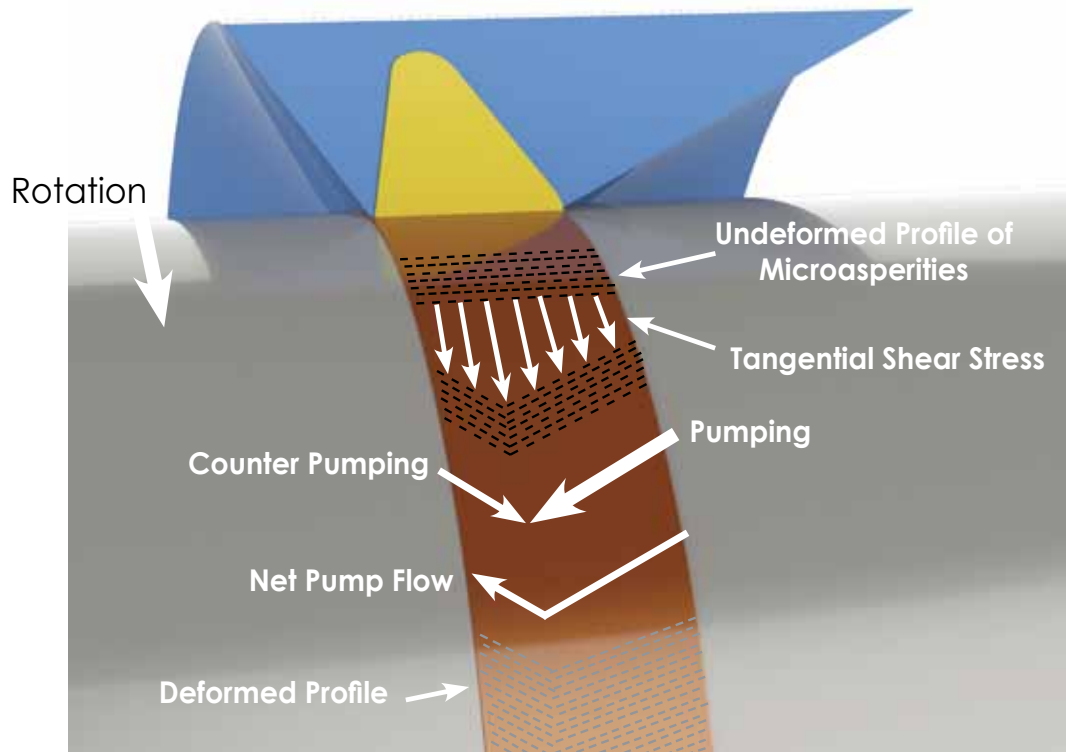

Contact Pressure Profile.

The existence of the asymmetric pressure profile, fluid film and asperities contribute to the pumping mechanism of the seal.

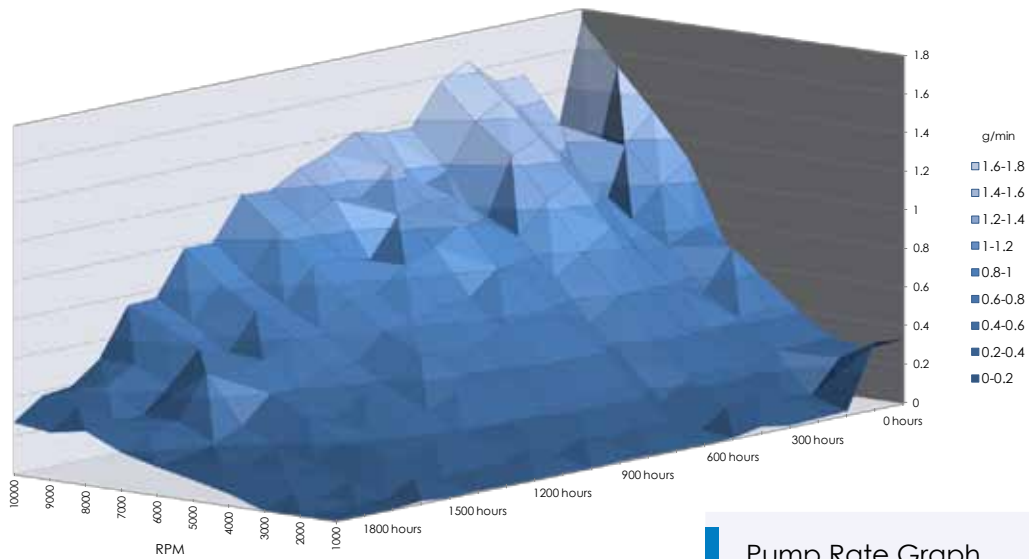

SEAL DESIGN

Pump Rate Graph.
 The graph displays how the pump rate of a seal lip will change over time.

In a lab environment, where the sealing lip is not affected by the ingress of dirt and debris a seal will eventually develop a leak after many hours of running. Leakage develops as the pressure profile of the lip contact on the shaft modifies and/or the asperities diminish.

Factors that modify lip pressure are wear and compression set of the elastomer. As the seal wears the contact width of the seal lip grows and the asymmetric pressure profile is modified. As well, the elastomer of the seal will develop compression set over time due to its exposure to fluid at elevated temperatures. The effect of the modification of the asymmetric pressure profile on the pump rate of the lip is shown above. The Pump Rate Graph displays the decrease in seal lip pump vs time vs RPM.

A second failure mode of the seal lip can occur as shaft speed increases. The oil film between the seal lip and shaft surface helps to protect and lubricate the rubber lip on the rotating shaft. Even with the oil film present there is frictional heat generated at the sealing lip. That heat can become significant at high shaft speeds and there are temperature limitations for various elastomers. Nitrile is the most commonly chosen due to cost, but if shaft speed is high, a fluorocarbon or Teflon material may be required.

RADIAL SHAFT SEAL TERMINOLOGY

There are different designs of radial shaft seal, some have more elements than other like for example a dust lip or inner case. The image below shows the terminology of a TC radial shaft seal.

SEAL DESIGN

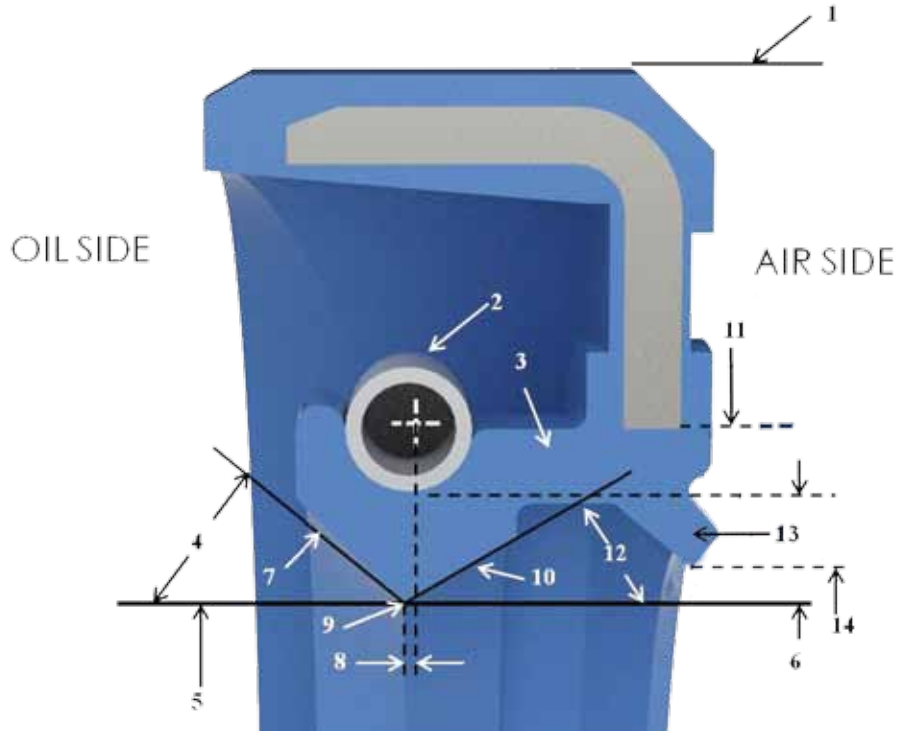

- | | |
|---------------------|--------------------------|
| 1. Seal OD | 8. Spring Axial Position |
| 2. Garter Spring | 9. Contact Point |
| 3. Flex Section | 10. Air Side Surface |
| 4. Oil Side Angle | 11. Case ID |
| 5. Lip ID | 12. Air Side Angle |
| 6. Head Thickness | 13. Dust Lip |
| 7. Oil Side Surface | 14. Shaft Diameter |

SEAL DESIGN

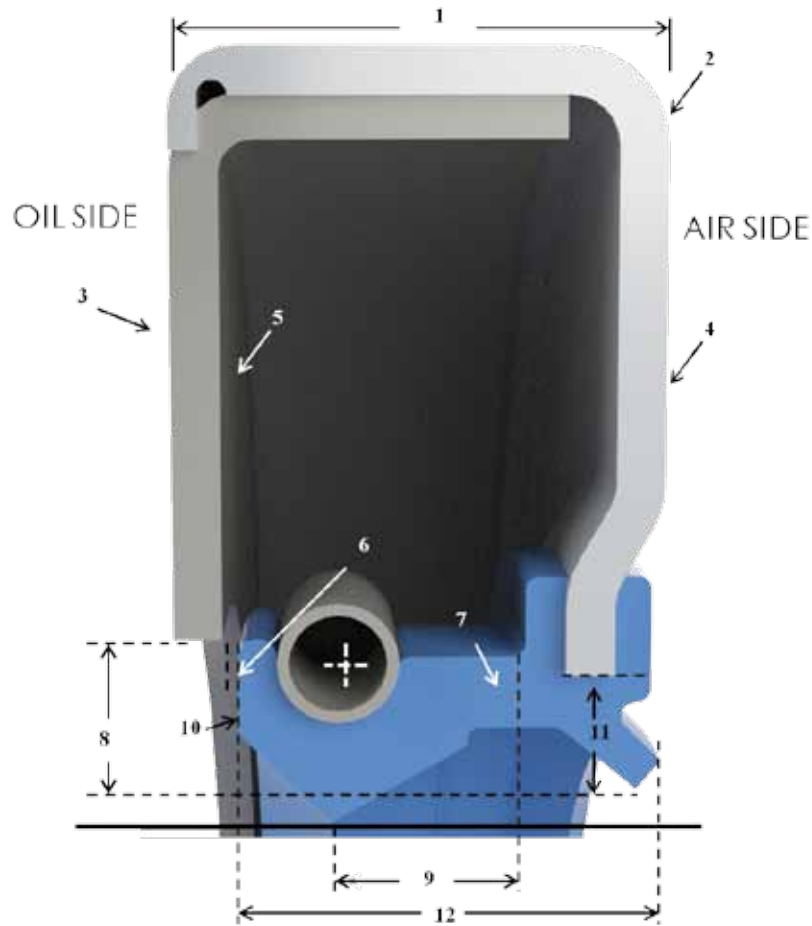

- | | |
|--------------------|-------------------------------|
| 1. Case Width | 8. Inside Face Inner Diameter |
| 2. Outer Case | 9. Lip Length |
| 3. Inside Face | 10. Toe Face |
| 4. Outside Face | 11. Outer Case Inner Diameter |
| 5. Inner Case | 12. Lip Height |
| 6. Axial Clearance | |
| 7. Heel Section | |

PARAMETERS AFFECTING SEALING

The process of defining a specific sealing system is the first step toward understanding the true application needs.

SEAL DESIGN

Certain parameters can affect the types of profiles that can be used. The design engineers ability to narrow down all of the system variables and understanding their affects will dictate the success of the profile selection.

There are four categories of system parameters that list common application variables; the housing, outside, media and shaft parameters.

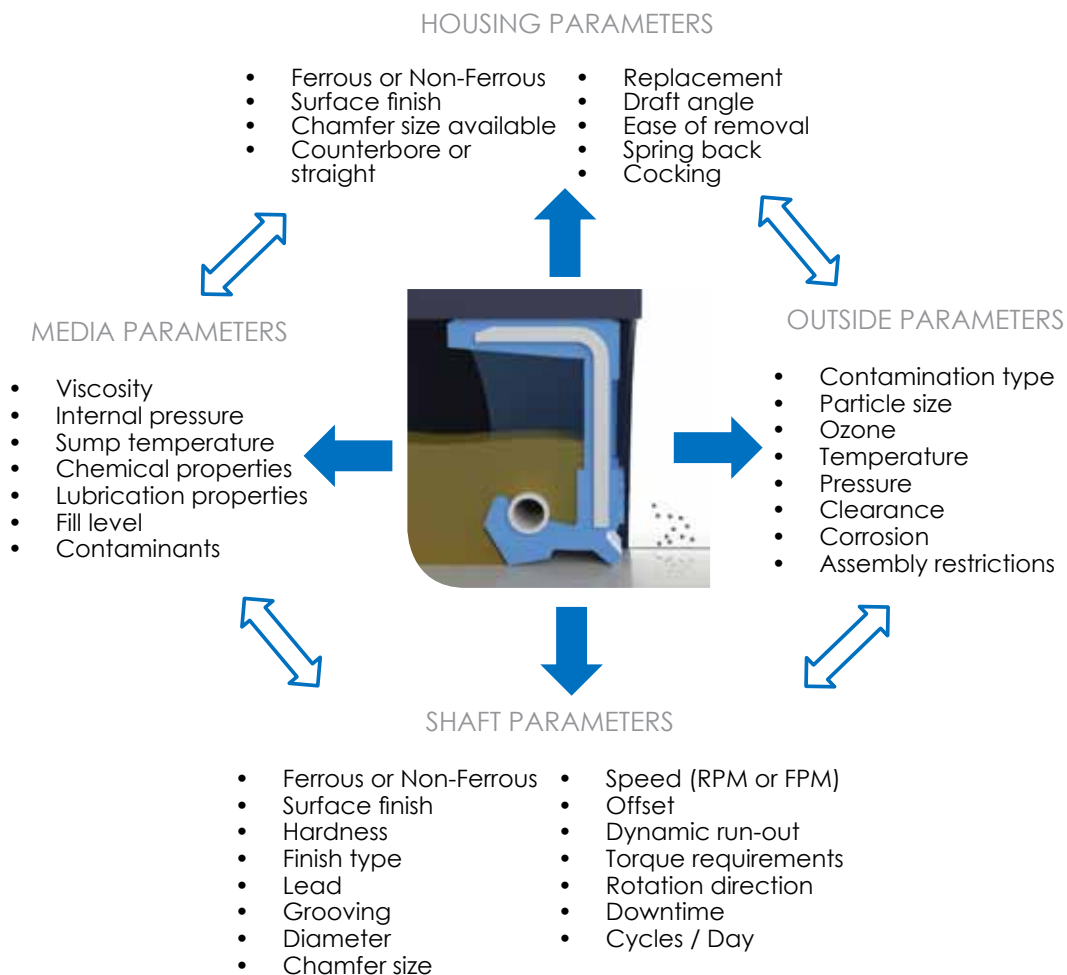

SEAL DESIGN

TEMPERATURE

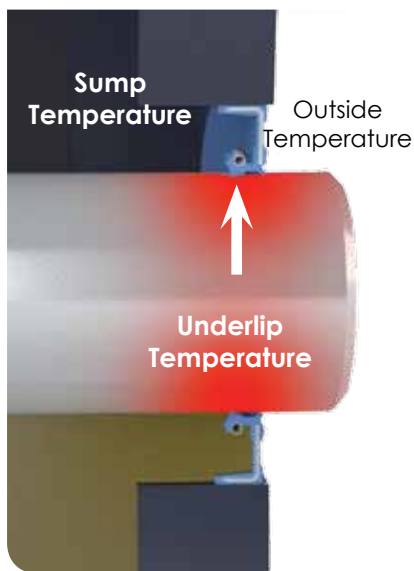

Temperatures affecting the seal.

There are three different forms of temperature: outside, sump and underlip.

There are three different forms of temperature: outside, sump and underlip. The cumulative effect of these temperatures can increase the hardening rate of the elastomeric lip material. This causes the loss of flexibility in the contact area, and ultimately decreases the life of a seal.

The outside temperature can come from any heat source other than the sump or underlip. Long exposure to high outside temperatures can have unexpected effects on the life of a seal. When combining these temperatures with the sump temperatures, an increase in the hardening rate of the elastomer may occur. The other end of the spectrum occurs when outside temperatures reach the lower limit of the lip material temperature range.

At low temperatures, the effect on the sealing element may result in tearing if there is dynamic run-out of the shaft due to a decrease in flexibility and resilience. Unless the seal experiences catastrophic failure, leakage does not normally occur at these low temperatures because the viscosity of the sump media has increased and due to friction the temperatures quickly elevates.

The sump temperature is the most common measure of the three temperatures. There is a direct correlation between seal life and sump temperature. Even if the seal is operating at sump temperature that is within the given elastomeric temperature range, this does not mean that the seal life is not being compromised. If long life cycles are an important priority, then a low sump temperature is desired. If long life-cycles are not a priority, then a high sump temperature can have a positive effect on the system. Fluid viscosity, seal torque and power consumption all decrease as sump temperature increases.

The underlip temperature of the contact width is a function of shaft speed, material friction, surface roughness, sump and outside temperature. As these parameters increase, the effect is a higher underlip temperature. The material friction is dependent on elastomer properties, radial lip load and lubrication. If there is no fluid film available, the seal element would burn up because of extremely high underlip temperature.

The cumulative effect of all of these temperatures is that the hardening rate of the lip material is increased and seal longevity is lost.

PRESSURE

Standard radial shaft seals are not designed to operate in a pressurized system. The flex section is too thin and has no rigid support. Even a slight increase in pressure can force the outside lip surface to pivot about the contact width, decreasing the air side angle. This condition is called bell mouthing and its effects are irregular wear and shortened seal life. The maximum industry pressure for standard profiles is 7 – 10 psi (0.48 – 0.69 bar). When dealing with pressures in this range it is important to also consider shaft speed. The optimal pressure for a standard radial shaft seal is near zero.

To choose a profile type the system pressure needs to be classified. Most radial shaft seals are designed for the standard pressure range. For applications in the medium/low range, the profile availability is significantly reduced.

To accommodate for these pressures, the lip length must be shortened and the flex section increased in thickness. High classification pressures require an additional structural member to assist the primary lip from deflecting and extruding. For applications with pressures higher than 150 psi contact ESP International for recommendations.

PRESSURE CLASSIFICATION	
Standard	0-10 psi (0-0.69 bar)
Low	10-50 psi (0.69-3.45 bar)
Medium	50-100 psi (3.45-6.9 bar)
High	100-150 psi (6.9-10.3 bar)

LUBRICATION

Lubricants are used to reduce wear of dynamic mechanical components. Radial shaft seals keep these lubricants contained within a cavity or sump. A radial shaft seal also rides on a film of fluid when rotating. This lubricant film is the primary reason the lip does not wear or burn up due to excessive friction. Even with lubricant present at the sealing lip, frictional heat is created and the dissipation properties of the lubricant can impact the life of a radial shaft seal. Also, the availability of lubricant can affect seal life, optimally the seal lip will be immersed in oil, but some applications employ splash or mist lubrication. These applications may have a negative effect on seal life.

The seal lip and the lubricant must be chemically compatible to prevent elastomer degradation. With high demands being placed on the lubricants, additives are used to improve performance of lubrication.

Unfortunately, these additives may have a negative effect and a compatibility problem is often seen when the elastomer hardens at low operating temperatures or the lip is excessively soft from normal use. A complete list of the additives in the lubricant is essential for a thorough analysis.

The following table shows a list of common additives used in lubricants:

CHEMICAL COMPOUNDS OF THE ADDITIVES	
Antifoamants	Silicone Polymers
Corrosion Inhibitors	Overbased Metallic Sulfonates Phenates, Fatty Amines
Detergents	Amines, Phenates, Succinimides
(EP) Antiwear Additives	Organic Phosphates, Chlorine, Sulfur Compounds
Friction Modifiers	Amides, Phosphates, Phosphites, Acids
Metal Deactivators	Metal Phenates, Nitrogen
Oxidation Inhibitors	Aromatic Amines, Hindered Phenols
Pour Point Depressants	LMW Methacrylate Polymers
Rust Inhibitors	Ester, Amines, Sulfonates

VISCOSITY

Viscosity is defined as the measured resistance to flow. The molecular weight and composition determine the viscosity.

The Viscosity Index is a unitless measure of the tendency of the lubrication to change viscosity due to a change in temperature. A low VI suggests the lubrication will have a significant change in viscosity with a small change in temperature.

Lubricants with high viscosities will create high levels of friction and therefore decrease seal life. Lubricants with low viscosities will reduce friction and power consumption. However, lower viscosities require an increased pump rate to maintain sealability.

The following formula is used to calculate the viscosity index:

$$V = 100 \frac{(L - U)}{(L - H)}$$

Where:

V = viscosity index

U = kinematic viscosity at 40° C

L and H = values based on the kinematic viscosity at 100° C

The kinematic viscosity values are available in ASTM D2270

SEAL DESIGN



Sump fill level.

Lubrication is a critical part of the seal's cooling system and should be continually monitored.

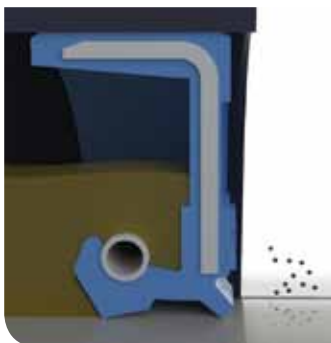

Contamination.

If contamination reaches the lip, the pumping action will ingest it into the system.

SUMP FILL LEVEL

As the sump level decreases, the life of the seal decreases. This can be explained through thermal analysis of the seal contact region of the shaft. Lubrication is a critical part of the seal's cooling system and should be continually monitored. When sump levels are not adequate to cool the seal, special lip materials such as PTFE should be considered.

CORROSION

Corrosion of the dynamic surface can cause damage or failure of the radial shaft seal. Elastomers can create an electrochemical reaction in the contact width region when heat and humidity are present. A seal that is idle for long periods is subject to this type of corrosion when temperatures are above 85° F (29° C).

The selection of corrosion resistive lubricants can inhibit the corrosion but will not eliminate it. If an electrochemical reaction is a concern, contact ESP International.

CONTAMINATION

The effect of contamination ingesting into a mechanical system can result in failure of bearings, gears and other dynamic components. Because of the pumping action under the contact width, if contamination is allowed to reach this point it will naturally ingest into the system.

Selecting a radial shaft seal profile that does not allow this to happen is necessary to avoid mechanical failure.

To classify the severity of contamination begin with identifying all potential particle types and sizes. Percentage of cycle exposure should also be considered, defined as the amount of time the seal is exposed to contamination during application. Another variable to consider is the maximum percentage that the seal is submerged.

Most radial shaft seals are designed to operate under a level 1 or 2 contamination environment. This includes radial shaft seal profiles having a secondary dust lip. This lip provides only minor protection and is often misused in applications.

The effect of this additional lip is an increase in under-lip temperature and a loss of seal life. When using this profile, it is important to lubricate between the two lips during installation to minimize this effect.

The effect of high percentages of exposure and submergence results in the reduction of available profiles. Severity levels of 4 and 5 requires special consideration of lip types, number and orientation. Contact ESP International for design suggestions.

Other important parameters to investigate when dealing with contamination are shaft speed, shaft hardness, duty cycles and down time. The Severity of Contamination can be ranked as following:

Contamination Level	Description	Particle Type	Particle Size	Percent Cycle Exposure	Max Percent Submerged
5	Extreme	Impactment, slurry, water, dust, abrasive particles	Powdery, fine and large	75-100	100
4	Heavy	Dirt, mud, water	Powdery, fine and large	50-75	75
3	Moderate	Dirt, splashing	Small/Moderate	25-50	25
2	Light	Air travel, dust	Small/Moderate	0-25	0
1	None	None	None	0	0

CASE DESIGN

COUNTER OR STRAIGHT BORE

The bore type affects the positioning of the primary sealing lip and the O.D. sealability. A counter bore should be designed to control the position of the primary sealing lip. If the case has a nose gasket incorporated into the design, this gasket will provide additional O.D. sealing by forming a face seal. If the bore is straight, then a stopping mechanism needs to be included on the installation tool or a flanged case needs to be used.

SEAL DESIGN

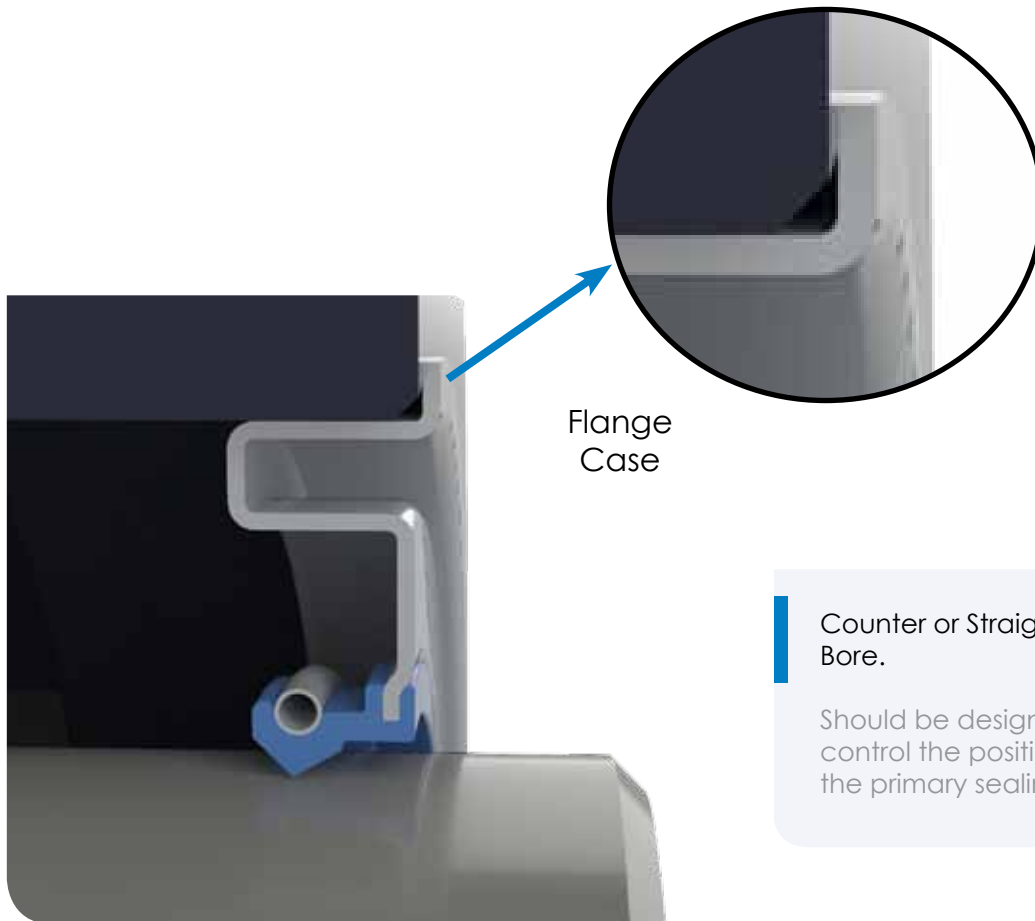

HOUSING ASSEMBLY

Radial shaft seals are pressed into a bore to form a static seal. The static seal can be created by a metal-metal, rubber-metal, or a combination interference.

The press fitting action positions the seal both axially and radially. The head and heel section are properly aligned if the outside face of the case is perpendicular to the shaft axis. The effect of poor installation is seal cocking or damage to the outside diameter.

Cocking is caused by improper installation methods. If there are such assembly space restrictions as a blind installation or no room to use the proper installation tool, alternative seal designs should be considered.

Failure to design a proper bore chamfer is the primary cause for damaging the seal O.D. A proper use of an installation chamfer allows for a positive pilot gap, positioning the seal against the chamfer prior to installation.

When a proper tool is used, installation forces, cocking and spring back are all minimized. The result is longer seal life and less chance of leakage. If a sufficient chamfer is not possible, a customized seal O.D. should be designed. Contact ESP International for design suggestions.

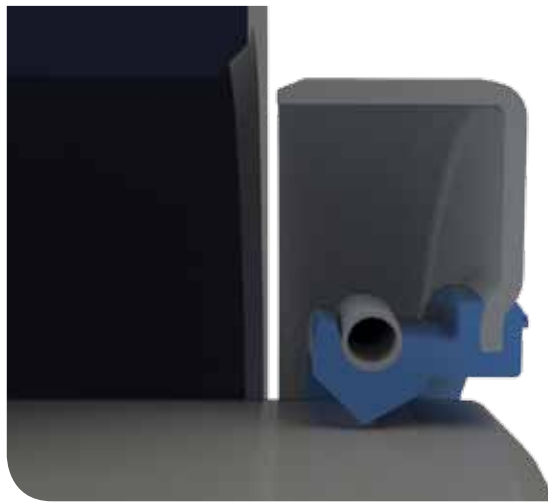

Housing Assembly.

The proper use of an installation chamfer allows for a positive pilot gap.

REPLACEMENT AND EASE OF REMOVAL

If the radial shaft seal is in a system that is serviced often, then the type of static OD needs to be considered. Metal press-fit OD requires low installation forces but are difficult to remove. There are also small particles of the bore removed when a metal press-fit is uninstalled.

If an application requires a dozen replacements over the life of the system, a metal press-fit would not be a proper choice. If ease of removal is important and the service may take place outside of a service shop then a pry flange may need to be incorporated into the design. These parameters should be considered and addressed early in the design process to save money and time for the aftermarket.

SEAL DESIGN

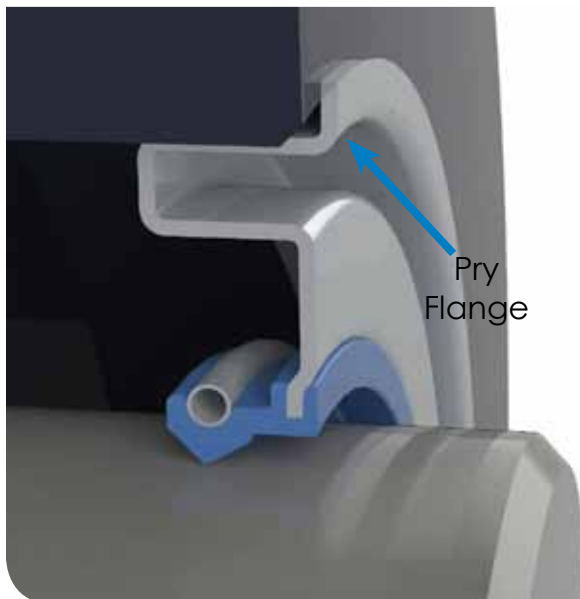

Ease of Removal.

If an application required several replacements over the life of the system, ease of removal is important.

SHAFT DIAMETER

Increasing shaft diameter results in higher frictional torque and required power. These increases will affect the underlip temperature and would require the revolutions per minute (RPM) to be lowered.

Because of associated costs and sealability it is preferred to minimize the shaft diameter of a radial shaft seal.

SHAFT HARDNESS

The shaft hardness is important for the contact width of the seal or for any part of the shaft that might contact the sealing lip. If the hardness is so soft that the shaft is susceptible to denting or nicking, then there could be seal damage caused during installation. A Rockwell hardness of 45 HRC or higher is recommended if the shaft is subject to being nicked by handling or assembly.

Such materials as bronze, brass and aluminum should not be used without a hardened steel wear sleeve because of excessive wear and grooving.

SHAFT SPEED

As shaft speed increases, the adverse effects of pressure, temperature, contamination, lead and wear all increase.

Sealing against extreme or heavy contamination is difficult for speeds above 500 ft/min. For these speeds, the frictional drag needs to be reduced to accommodate the high underlip temperature making it difficult to keep out contamination.



Shaft.

Increasing shaft diameter results in higher frictional torque and required power.

SEAL DESIGN

As shaft speeds reach 3000 ft/min the pumping action across the primary lip will begin to degrade, especially if there is a slight lead angle. A hydrodynamic aid may need to be added to the air-side angle to counteract the loss in pumping action and increase the inward pumping rate. This will also help keep the film of lubrication under the contact width, decreasing the underlip temperature and increasing the life of the seal.

Speed (ft/min)	Classification
0-500	1
500-750	2
750-1750	3
1750-4000	4
4000 and up	5

SHAFT ASSEMBLY

Incorrect installation direction or the absence of a shaft chamfer can cause damage to the seal lip or cause it to roll during installation.

Shaft installation direction should be considered for triple lip profile types to insure proper lip orientation for dirt exclusion.

If the shaft chamfer is less than design specifications the chances of rolling the sealing lip increases. If the assembly area is restricted or there is a blind installation, an alternate seal profile may need to be selected.

FINISH TYPE AND LEAD

The finishing process on the shaft will affect the sealability of the system. The microscopic effects of how the fluid media reacts at the contact width determines the hardening rate of the elastomer materials.

The lead angle present on the shaft affects how the fluid transfers itself along the surface of the shaft. Lead acts as a screw during rotation. If the lead angle is along the direction of rotation and the angle is larger than 0.05°, leakage may occur.

Using the steps listed below, a simple process for determining the lead direction and angle can be followed.

PROCEDURE TO DETECT SHAFT LEAD	
STEP	DESCRIPTION
1	Mount shaft in holding chuck
2	Eliminate any wobbling or run-out, level shaft
3	Loop a thin thread over the shaft
4	Attach a 1 oz (30 g) weight to thread with 2/3 contact
5	Set shaft rotation to 60 RPM
6	Observe thread movement in axial direction
7	Record results in both directions of rotation

After gathering data on the rate of axial movement of the thread, the lead angle can be calculated using the formula below:

$$\text{Lead Angle} = \text{ArcTan} \frac{\text{Axial Movement of String}}{(\text{Shaft Circumference})(\text{No. of Revolutions})}$$

The lead angle of the shaft should be $0^\circ \pm 0.05$. Example: If a string advances 0.4" in 1 minute on a 3.0" shaft rotating at 80 RPM.

$$\text{Lead Angle} = \text{ArcTan} \frac{0.4}{(3 \pi)(80)}$$

For more detail information about finish type and lead, check Section 10 of SAE Fluid Sealing Handbook Radial Lip Seals (SAE J946).

INTERPRETATION OF THREAD MOVEMENT

RIGHT HAND LEAD OR CW

CW Rotation: Moves from chucked end to free end

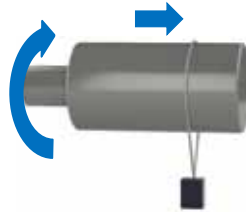

CCW Rotation: Moves from free end to chucked end

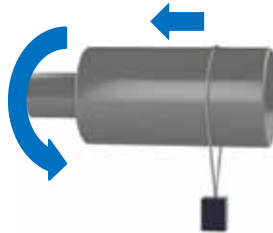

LEFT HAND LEAD OR CCW

CW Rotation: Moves from free end to chucked end

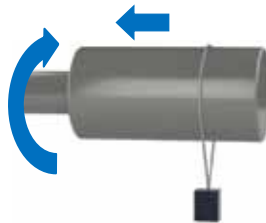

CCW Rotation: Moves from chucked end to free end

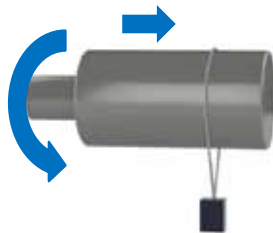

SEAL DESIGN

NO LEAD

CW Rotation: Stationary

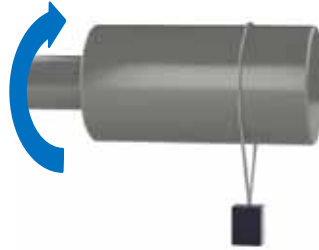

CCW Rotation: Stationary

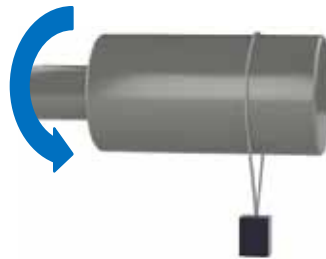

TAPERED SHAFT

CW Rotation: Moves in same direction no matter shaft rotation. Remounting the shaft reverses direction

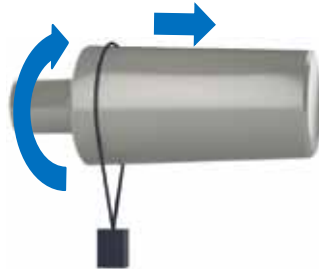

CCW Rotation: Moves in same direction no matter shaft rotation. Remounting the shaft reverses direction.



CUPPED SHAFT

CW Rotation: Moves toward center

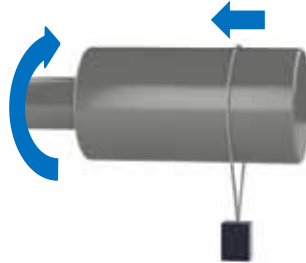

CCW Rotation: Moves toward center

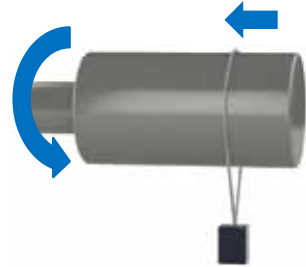

CROWNED SHAFT

CW Rotation: Moves away from center

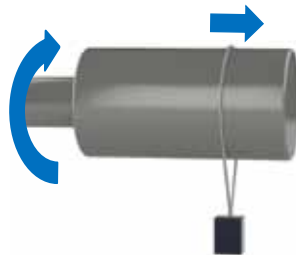

CCW Rotation: Moves away from center

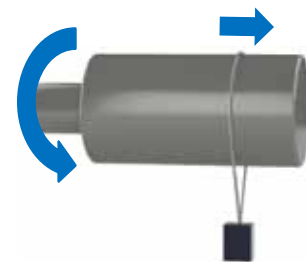

SEAL DESIGN

FERROUS OR NON-FERROUS

The choice of housing and shaft materials will affect the type of materials that can be used for the seal OD and lips.

The most common restriction when considering a housing material is the instance when two materials have a different coefficient of thermal expansion. This effect needs to be considered with larger diameter seals.

If a carbon steel case is pressed into an aluminum bore, a ten-inch diameter seal is more likely to experience OD leakage than a one-inch seal. When non-ferrous materials are used, other parameters should also be analyzed: hardness, surface finish and galvanic corrosion.

If a non-ferrous shaft must be used, contact ESP International for consultation.

Material	Type	Coefficient of Thermal Expansion
Steel	Ferrous	7 μ in/in-°F (12.6 μ m/m-°C)
Aluminum	Non-Ferrous	12.7 μ in/in-°F (22.9 μ m/m-°C)
Nitrile	Non-Ferrous	62 μ in/in-°F (111.6 μ m/m-°C)

SURFACE FINISH OR TEXTURE

The elastomeric lips of radial shaft seals have enough elasticity to insure that the lip will follow the normal form and waviness errors of a shaft to maintain a seal. However, the life of the seal is affected by the microscopic imperfections of the surface finish.

Surface finish, or texture, consists of peaks and valleys that make up a surface and their direction on the surface. During analysis, surface finish can be broken down into three components: roughness, waviness and form.

ROUGHNESS

Is a direct relation to tool marks. Every pass of a cutting tool leaves a groove of some width and depth. Roughness is also what can form a lead angle.

WAVINESS

Is the result of small fluctuations in the distance between the cutting tool and the work piece during machining. This is caused by cutting tool instability and vibration.

FORM ERROR

Is caused by lack of straightness or flatness in the machine tools. Form error is highly repeatable error, because the machine will follow the same path each time.

All these surface finish components exist simultaneously and are superimposed over one another. In some cases, these are determined separately but normally the total profile surface finish incorporates all three.

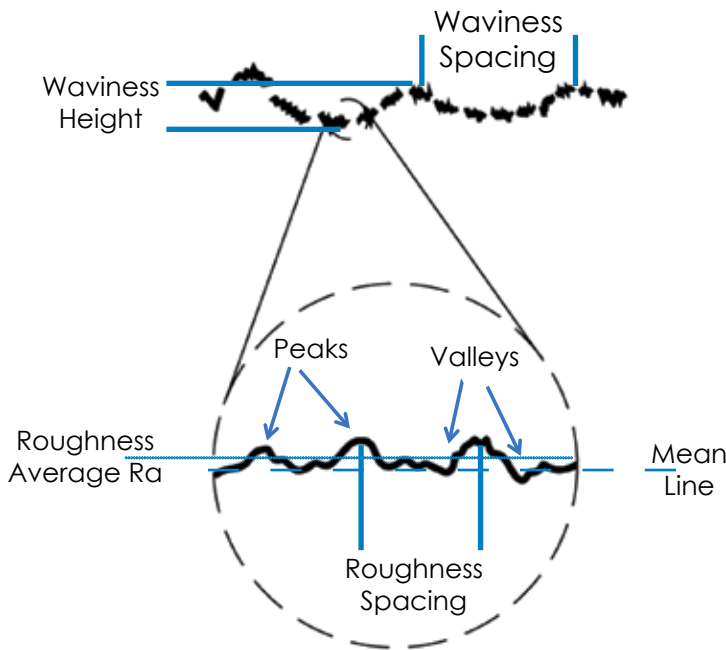

Surface finish.
Consists of peaks and valleys that make up a surface and their direction on the surface.

SURFACE PREPARATION



PLUNGE GRINDING

The grinding wheel is normal to the shaft axis at contact and does not traverse back and forth. The result is short to medium grinding marks that have little to no lead. This process can be relatively expensive but only needs to be performed in the seal contact region. Grade A.



PAPER POLISHING

This method is very effective if constant pressure is applied over the width of the emery cloth. Automatic equipment is more consistent than polishing by hand. Grade B.

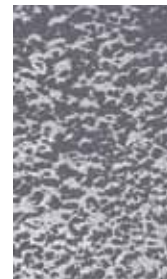

METAL PEENING

Small metal particles are impelled on the surface, imposing compressive stresses in the skin of the shaft. This is a secondary process that eliminates the potential of lead. Grade B.



GRIT BLASTING

Media such as sand is impelled onto the shaft as a secondary process. If correctly applied, machine lead can be eliminated. Grade B.

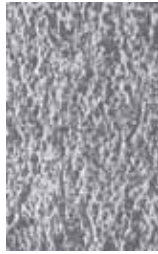

TUMBLING

Method produces a uniform aggregate appearance and removes minor surface irregularities. Grade C.



TRANSVERSE GRINDING

A centerless grinder is used as either the shaft or the wheel moves axially through the grind zone. This method can produce spiral grooves and can result in seal leakage. Grade D.



HONING

The resulting finish is a criss-crossing pattern that produces a pumping condition likely to cause a leakage. Grade F.



DIAMOND BURNISHING

In this process the media moves axially and does not remove machine lead, but instead makes it worse. Grade F.



MACHINE TURNING

Machine turning will almost always generate lead and should be followed with a subsequent secondary operation. Grade F.

ROUGHNESS MEASUREMENT

Average roughness or Ra, is the parameter most widely specified and measured. The algorithm for Ra calculates the average height of the entire surface from a mean line. This is an effective way to monitor process stability, and it is used to control surface finish for radial shaft seals.

An important consideration when looking at Ra is that different surfaces may have the same Ra value with more wave heights and spacing. There are more than a dozen roughness parameters specified by ASME Standard B46.1. Many of these can be used to further control the surface finish. Contact ESP International for further discussion.

SEAL DESIGN

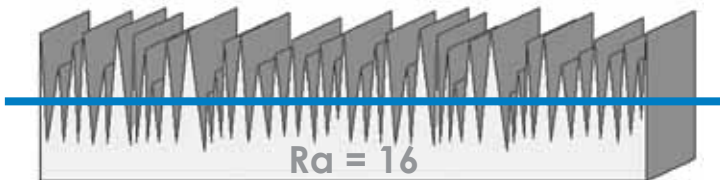
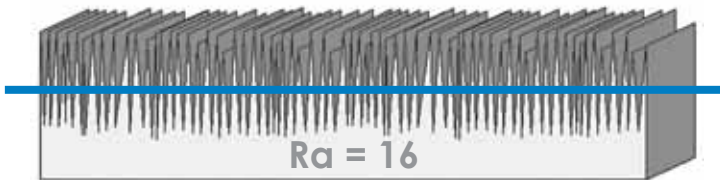
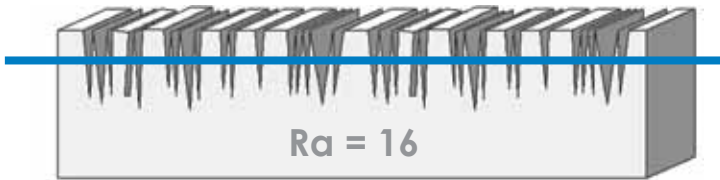

Surface finish.

Finishes with the same Ra but different surface profiles

SEAL DESIGN

CYCLE TIME / DOWN TIME

Cycle time and down time are parameters that when combined with other variables such as underlip temperature, shaft speed and contamination can either increase or decrease their effect on sealing.

The identification of the length of the cycle time will classify the severity of its affect on other parameters. An example of this is an application that runs continuously, it is expected to have a high negative effect on the underlip temperature. An alternate material or lip design may be chosen as a result.

Downtime is generally considered in combination with cycle time. The reason for this can be illustrated in an example where the cycle time is a level 1, but so is the down time.

The resultant effect is equivalent to a continuous cycle time even though the true cycle time is only 30 minutes or less.

Classification	Down Time
1	1 hr/Day
2	2-4 hr/Day
3	5-12 hr/Day
4	Days
5	Weeks
6	Seasonal

Classification	Cycle Time
1	30 min or less
2	1 hr
3	2-4 hr/Day
4	5-12 hr/Day
5	12-16 hr/Day
6	Continuous

SELECTING A RADIAL SHAFT SEAL

Deciding on the type of radial shaft seal is a challenging process that requires selecting specific seal design characteristics to match the system parameters. The design engineer should organize the potential parameters and prioritize them in order of severity and importance.

Selecting a radial shaft seal profile requires deciding the following: lip type, case type and the use of a hydrodynamic aid. There are many different radial shaft seal profiles available in the industry and a hydrodynamic aid can be added to the primary lip of most spring loaded lip styles. All three of these design variables need to be considered separately and then combined to form a radial shaft seal profile.

First consider the application basics. This will help to narrow the lip selection immediately. The application study below provides an example of a common separation that usually requires different lip styles. Developing your own application studies that are specific to your industry is a valuable selection tool.

SEAL DESIGN

APPLICATION STUDY: Grease vs. Oil Retention

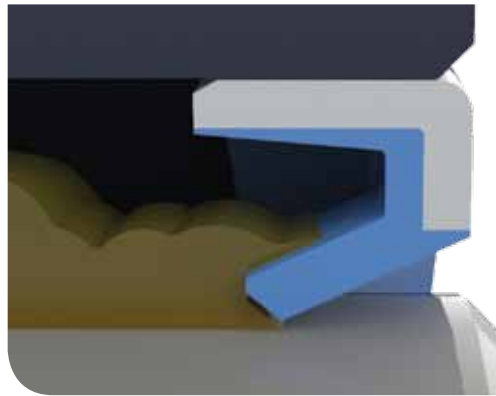

Grease Retention

The viscosity of grease is much higher than oil and is much easier to retain. Therefore, a non-spring loaded lip is both sufficient and cost effective for this application. If contamination is the primary control parameter, then the seal should be installed in the opposite direction shown above.

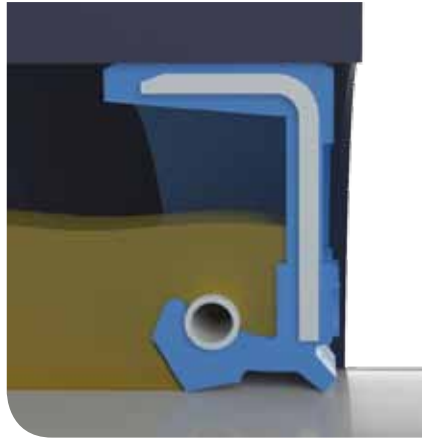

SEAL DESIGN

Oil Retention

The retention of oil is a more challenging task than grease because of the low viscosity of oil. A spring is required to help maintain the proper radial load for sealing. The spring is installed facing the fluid and hydrodynamic aids are sometimes molded to the air side angle to assist in the sealing action.









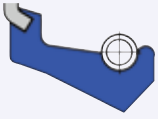

LIP SELECTION

Lip style is directly related to the media type, shaft speed, pressure, temperature and contamination parameters. The media used in the application can go from oil and grease, to other types like water, food and dairy products. All of these will affect the choice of available styles.

The effectiveness of your radial shaft seal depends on the lip type selection. This is the most important design variable and will determine both the life expectancy and cost.

The following table shows the most common lip styles, their names, applications and descriptions. There are many other available lip styles when trying to accommodate special parameters or extreme environments.

SEAL DESIGN

APPLICATION	LIP TYPE	DESCRIPTION	
Oil retention	Standard "S" Lip	This style of lip is used for standard pressure oil sealing in clean environments. May be reversed for extreme grease sealing.	
Oil retention for medium pressure applications	Standard "SN" Lip	This style of lip has a shortened flex section to accommodate medium pressure.	
Oil retention for dusty applications	Standard "T" Lip	This style of lip is used for standard pressure oil sealing in dusty/dirty environments.	
Oil retention for medium pressure applications	Standard "TN" Lip	This style of lip has a shortened flex section to accommodate medium pressure	
Grease retention	Standard "V" Lip	This style of lip is used for standard pressure grease sealing in clean environments. May be reversed to purge grease cavity.	
Grease retention for dusty applications	Standard "K" Lip	This style of lip is used for standard pressure grease sealing in dusty/dirty environments.	
Oil retention for applications with low lubrication	Standard "X" Lip	This style of lip is used for standard pressure sealing of none lubricating fluids. Inverted dust lip retains grease near sealing lip.	
Separating two fluids	Standard "D" Lip	This style of lip is used for standard pressure separation of two fluids	
Grease retention in heavy contamination environment	Standard "U" Lip	This style of lip is used for standard pressure grease sealing in extreme/heavy contamination environments. Flexible lips allow for purging of grease cavity from either direction.	
Grease retention in heavy contamination environment	Standard "T9" Lip	This style of lip is used for standard pressure grease sealing in extreme/heavy contamination environments. Lip on outside face is designed to act as an axial face seal.	
Contamination exclusion	Standard "WP" Lip	This style of lip used for scraping and wiping in hydraulic and pneumatic cylinder applications.	

CASE SELECTION

The most common and cost effective case materials are stamped from cold rolled carbon steel. The steel is then phosphate coated to aid in the molding process and to help eliminate corrosion during storage. Other case materials include stainless steel, brass and aluminum. These materials are considered special because of their additional cost, and are not typically used. The other option for case materials is fully coated or partially coated rubber. Carbon steel cans are usually selected for rubber molded options.

The case geometry controls the positioning and rigidity of the seal lips. Often overlooked, the case type can affect the life of the sealing system. The case forms a static OD radial seal and is susceptible to leakage if not properly designed. The table on the next page shows common case geometries and their advantages.

SEAL DESIGN



SEAL DESIGN

APPLICATION	LIP TYPE	DESCRIPTION
Spring back is not acceptable Ease of installation	Standard "L" Case	This style of case is the most common and economical design. A chamfer or curl is used to aid in installation.
Soft alloy housing Frequent removal High surface roughness	Rubber Covered Case	This style of case is used for soft alloy or plastic housing. Used for frequent removal and installation when damage to housing bore is a concern.
High surface roughness Counter bore Corrosion by sealing fluid	Nose Gasket Case	This style of case is an economical design used when surface roughness is outside specified limits. Also for use when corrosion by sealing fluid could be a problem.
Ease of removal Field install	Shotgun Case	This style of case is an economical design used when frequent removal is necessary. Also aids in installation when a field install may be needed.
Blind installation of shaft Structural rigidity	Secondary or Inner Case	This style is used when damage may occur to the sealing lip when shaft is installed. Also adds structural rigidity to radial shaft seal.
Reduce spring back Ease of installation	Heel Case	This style combines the ease of installation of metal OD seal with OD sealability of rubber covered case.

LIP MATERIAL SELECTION

Selecting an elastomeric material is important to the life of a radial shaft seal. The elastomer's resistance to temperature, abrasion, chemicals, weather, sunlight and ozone can affect a profile's success in an application. The base polymer must be selected to ensure that these parameters are satisfied without creating excessive cost.

SEAL DESIGN

There are a variety of compounds available depending on the system parameters. For parameters or chemicals that are not listed, contact ESP International for more information.

Properties	Nitrile	Ethylene Propylene	Fluorocarbon	Silicon	Polyacrylate	HNBR	PTFE (Teflon)
Temp. °F Temp. °C	(-40) - 250 (-40) - 120	(-50) - 300 (-45) - 150	(-30) - 400 (-34) - 200	(-80) - 350 (-60) - 175	(-30) - 300 (-34) - 150	(-10) - 300 (-23) - 150	(-100) - 500 (-75) - 250
Abrasive Resistance	Good to Excellent	Good to Excellent	Good	Poor to Good	Fair to Good	Good to Excellent	Poor to Good
Solvent Resistance							
Aliphatic Hydrocarbons	Good to Excellent	Poor	Excellent	Poor to Fair	Excellent	Good to Excellent	Outstanding
Aromatic Hydrocarbons	Fair to Good	Poor	Excellent	Poor	Poor to Good	Poor to Fair	Outstanding
Ketones	Poor	Good to Excellent	Poor	Poor	Poor	Poor	Outstanding
Lacquer Solvents	Fair	Poor	Poor	Poor	Poor	Fair	Outstanding
Resistance							
Weather	Poor to Fair	Excellent	Excellent	Excellent	Excellent	Good to Excellent	Excellent
Sunlight	Poor	Outstanding	Good to Outstanding	Excellent	Good to Excellent	Fair to Good	Outstanding
Ozone	Poor to Fair	Good to Excellent	Outstanding	Excellent to Outstanding	Good to Excellent	Good to Excellent	Outstanding

HYDRODYNAMIC SEALING AIDS

The hydrodynamic effect and the dynamic sealing mechanism discussed earlier in this chapter provide an explanation of how a radial shaft seal works in application. The pumping action provides continuous lubrication for the contact width of the elastomer lip.

When certain parameters are pushed to extremes – such as shaft speed, lead and viscosity – the pumping mechanism needs some support.

SEAL DESIGN

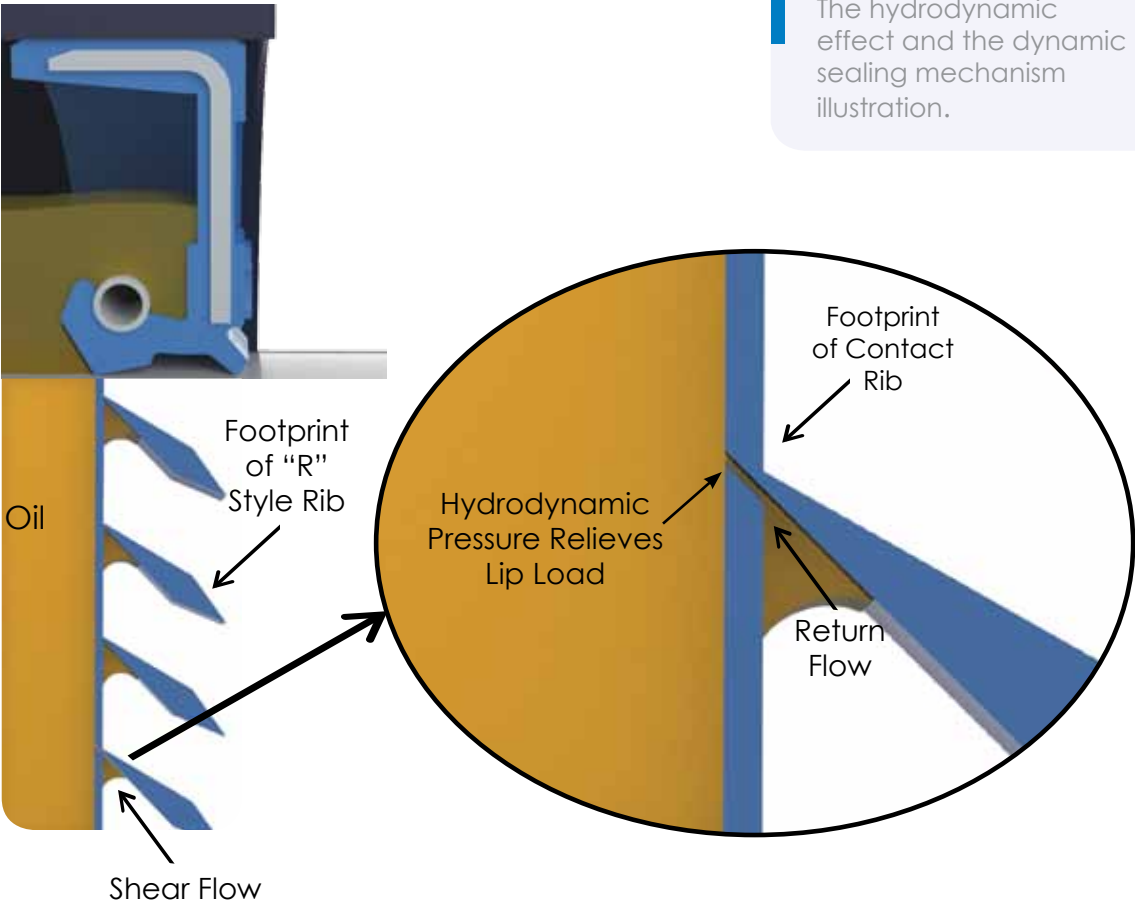

Hydrodynamics Sealing Aids.

The hydrodynamic effect and the dynamic sealing mechanism illustration.

SEAL DESIGN

Hydrodynamic sealing aids assist in the dynamic sealing mechanism, and increase the pumping rate back to sump. Oil that escapes past the contact width is forced back by the rotating shaft into the converging space between the rib and the lip.

The benefit of using hydrodynamic aids is the increase of underlip pressure, decrease in friction, lower running temperature and ultimately can provide longer life. In cases where there is potential for small scratches and nicks on the shaft in the contact region, aids are used to overcome the potential for dynamic leakage.

Hydrodynamic aids are available in different patterns and as both unidirectional and bidirectional. Unidirectional aids are for both clockwise or counter clockwise shaft rotation. Be aware using a clockwise unidirectional aid in a counterclockwise application will result in a large fluid leak. As the hydro-aids will act in reverse, pumping oil out of the sump.

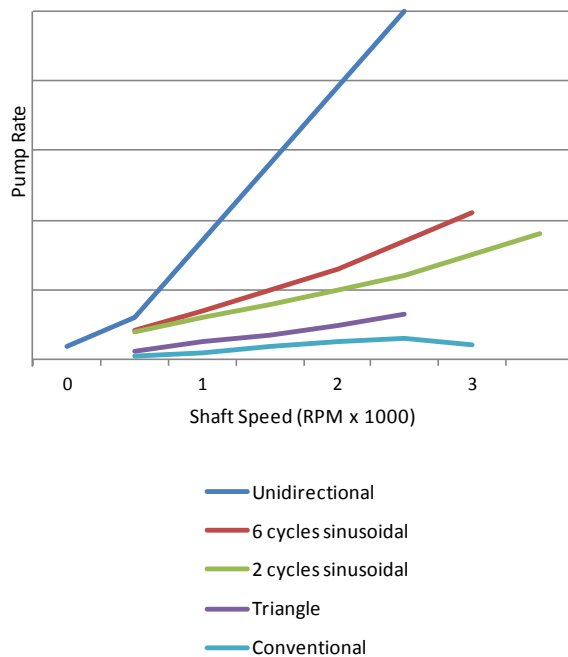

Hydrodynamics Sealing Aids.
 The chart shows the different pump rates that various hydrodynamic sealing aids have.

The actual hydro aid has very specific geometry requirements. The most common issues are shown below and can be detected by installation on an acrylic shaft.

SEAL DESIGN

UNIDIRECTIONAL HELIX RIBS

No contact with primary lip		
Helix ribs too high		
Helix ribs too shallow		
Good helix ribs and contact pattern		

BI-ROTATIONAL PADS

No contact with primary lip		
Pads too high		
Pads too shallow		
Good pads and contact pattern		

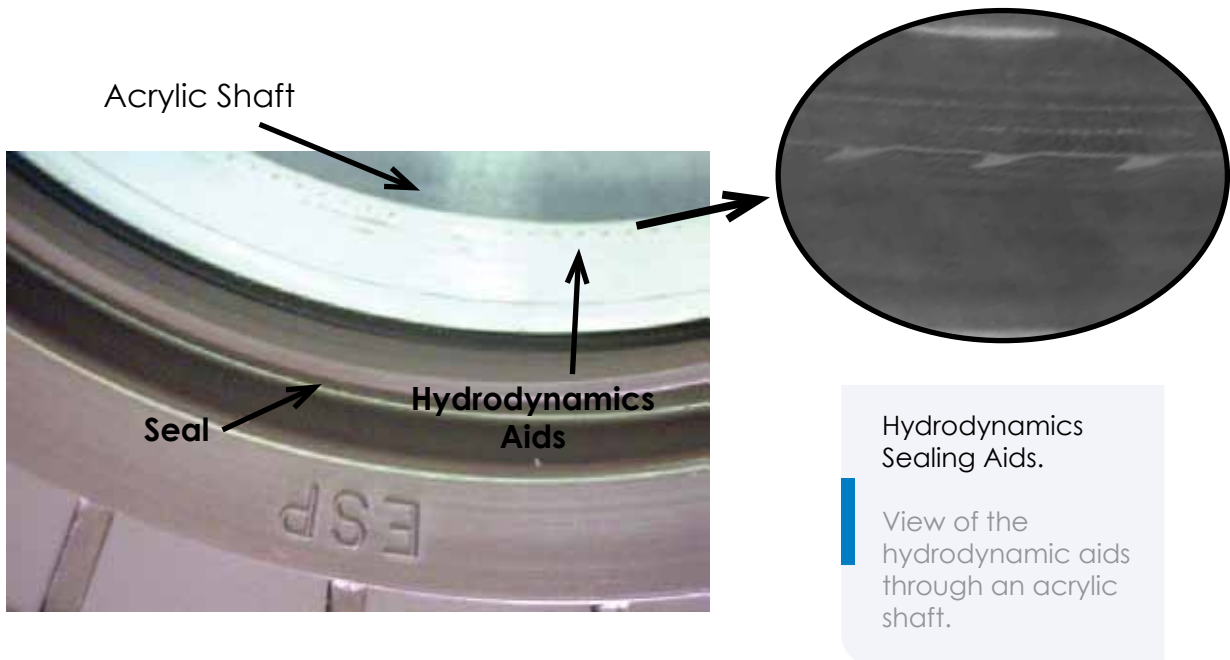

THE SPRING

When the fluid being sealed has high viscosity, the seal does not need a garter spring because the fluid will not flow easily. But when the fluid has low viscosity, like oil for example, the seal needs to have a garter spring to keep the lip pressed onto the shaft. Also, after the lip material has swelled and softened the spring increases the ability of the lip to follow the shaft dynamics.

Spring location is critical in a seal design, the spring must be set back from the lip towards the air side. Failing to do this will produce an inadequate pressure profile at the lip point and will result in a seal that leaks.

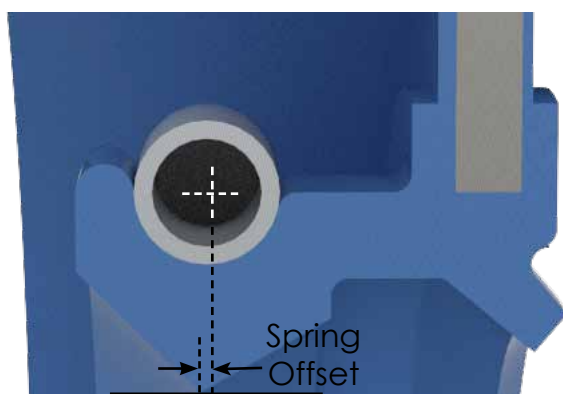

Spring Offset.

The spring must be set back from the lip towards the air side.

CUSTOM PROFILE DESIGN

The process of choosing a radial shaft seal to match all of the system parameters is often challenging, and in some cases not possible with standard profile designs. Each application should be reviewed in detail and the appropriate seal selected for the application. At times a standard cross section will suit a particular application, but in difficult/non-standard applications a custom seal can be designed with little effort.

The future of radial shaft seals is centered around the relationship of the customer and manufacturer. ESP International is dedicated to provide technical solutions at a competitive price. Proposing a custom design solution is not as valuable if the tooling cost is too high to consider prototyping. Our engineering department recognizes this and is confident that we can offer designed solutions at a competitive price.

SHAFT SPECIFICATIONS

SHAFT MATERIAL:

Most shafts are made from a carbon steel or cast iron, typically a material that can produce a surface hardness above 30 HRc is recommended.

Chrome or nickel plating can provide a hard surface and prevent corrosion in harsh environments. Brass, bronze, aluminum, zinc, magnesium and other soft metals should not be used due to the excessive shaft wear and grooving. Wear sleeves of mild steel should be pressed over the shaft if these materials are used.

SHAFT HARDNESS: Rockwell C30

The seal contact area of the shaft should be hardened to a minimum of 30 HRc under normal conditions. There is no conclusive evidence that a hardness above HRc will improve wear resistance except under extreme abrasive conditions. A Rockwell hardness of 45 HRc or higher is recommended if the shaft is subject to being nicked by handling prior to assembly.

SHAFT SURFACE FINISH: 10-20 Micro Inches

Seal leakage in some applications could be directly linked to such shaft imperfections as machining lead. Therefore, machine lead is held to a tight tolerance of $0^{\circ}\pm 0.05^{\circ}$. Seal counter surfaces should be plunge ground to 10-20 micro-inches Ra roughness (0.25-0.50 micro-meters) in order to create satisfactory sealing performance.

Machining Lead:	$<0^{\circ}\pm 0.05^{\circ}$
Grinding Chatter:	No grinding chatter allowed > 45 cycles
Roundness:	Out of roundness must be less than 0.0002" (0.00508 mm) and a minimum number of lobes
Lobing:	Maximum of 7 lobes at 0.0001"

SHAFT TOLERANCE

Shaft tolerances are normally held tight because they are often used in conjunction with bearings or bushings. In general applications, be sure the shaft diameter is within the following recommended tolerances. The tolerance range should be decreased for high speed or high pressure applications.

SEAL DESIGN

Shaft Diameter (millimeters)	Tolerance
Over 6 to 10	+0.000/-0.090
Over 10 to 18	+0.000/-0.110
Over 18 to 30	+0.000/-0.130
Over 30 to 50	+0.000/-0.160
Over 50 to 80	+0.000/-0.190
Over 80 to 120	+0.000/-0.220
Over 120 to 180	+0.000/-0.250
Over 180 to 250	+0.000/-0.290
Over 250 to 315	+0.000/-0.320
Over 350 to 400	+0.000/-0.360
Over 400 to 500	+0.000/-0.400

Shaft Diameter (inches)	Tolerance
Up to and including 4.000	±0.003
4.001 to 6.000	±0.004
6.001 to 10.000	±0.005
10.001 and larger	±0.006



Shaft Specifications.

When designing the shaft, the material, hardness, surface finish and tolerance need to be considered.

SHAFT CHAMFER OR LEAD IN RADIUS

A shaft should always have a burr free lead-in chamfer or radius to prevent damage to radial shaft seal during installation. The chamfer or radius allows the seal to change from its free diameter to the installed diameter without the sealing lip rolling or tearing. If a shaft does not have the recommended lead-in chamfer or radius, an assembly cone should be used during installation.

SEAL DESIGN

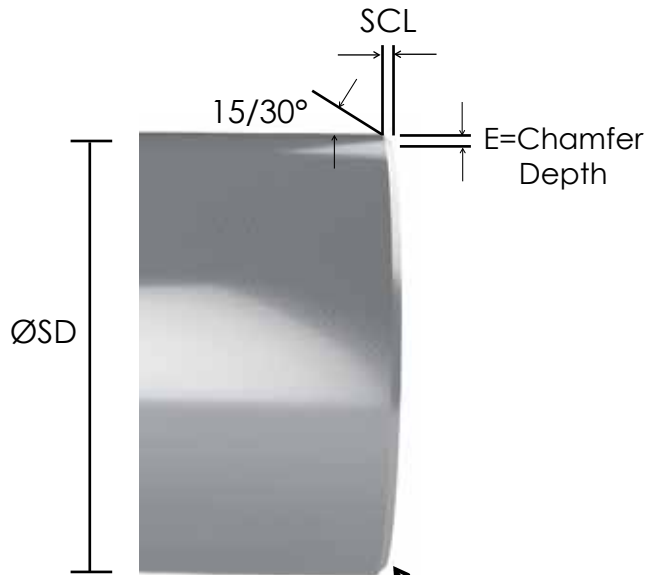

Shaft Chamfer.

Should always have a burr free lead-in chamfer or radius to prevent damage to the seal during installation.

These corners must be burr free and blended



Shaft Dia. ØSD (inches)	E	R	Preferred SCL@15°	Optional SCL@30°
Up to 4.000	0.093	0.188	0.347	0.156
4.001 to 7.000	0.125	0.250	0.466	0.218
7.001 to 40.000	0.188	0.375	0.702	0.323
40.001 and up	0.250	0.500	0.933	0.433

SEAL DESIGN

Shaft Dia. ØSD (millimeters)	E	R	Preferred SCL@15°	Optional SCL@30°
Up to 100.0	2.5	4.5	8.5	4.0
100.1 to 180.0	3.0	6.0	11.5	5.0
180.1 to 1000.0	5.0	9.5	18.0	8.0
1000.1 and larger	6.5	12.7	24.0	11.0

SHAFT ECCENTRICITY

To ensure a high performing radial shaft seal, Shaft-To-Bore-Misalignment (STBM) and Dynamic Run-Out (DRO) should be kept to a minimum.

STBM is the amount by which the shaft is off center with respect to the bore's center. STBM is caused by machining and assembly inaccuracies. To measure, attach a dial indicator to the shaft (between shaft and bore), rotate the shaft and read the indicator. STBM is HALF the Total Indicator Reading (TIR).

SEAL DESIGN

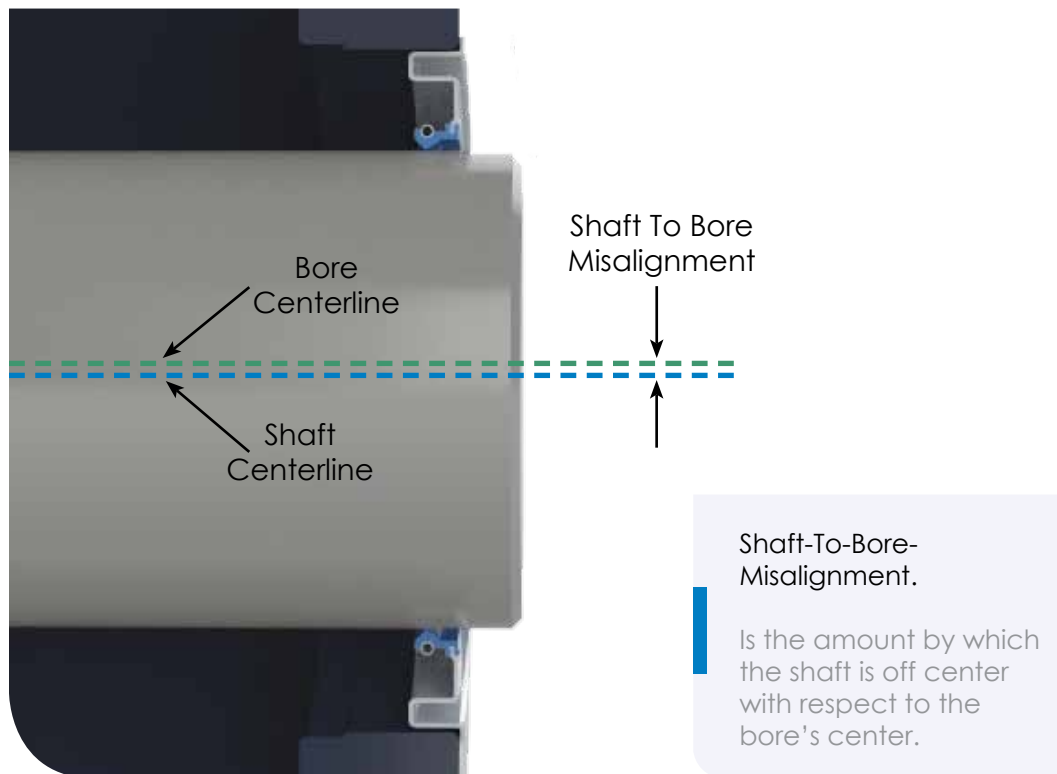

DRO is the amount by which the shaft does not rotate around the true center. Misalignment, shaft bending, lack of shaft balance and other manufacturing inaccuracies are common causes. To measure, slowly rotate the shaft and read the TIR of a dial indicator as shown below.

SEAL DESIGN

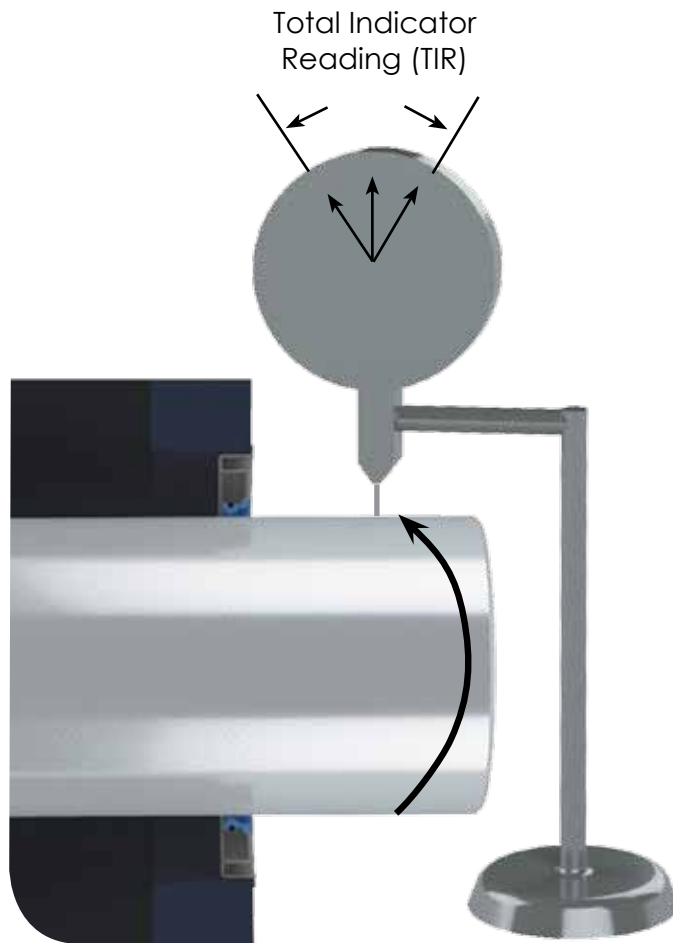

Dynamic-Run-Out.
 Is the amount by which the shaft does not rotate around the true center.

BORE SPECIFICATIONS

BORE MATERIAL

Ferrous metal such as steel and cast iron are acceptable, but aluminum and plastic housings may also be used. If an aluminum or plastic housing is used, then a rubber OD radial lip seal is recommended due to the differences in thermal expansion between the seal and the housing, because rubber has a higher thermal expansion than carbon steel, rubber will tighten in the bore as the temperature rises.

BORE SURFACE FINISH: 100 micro-inches

Excessively rough bore finishes may allow paths for fluid to leak between the radial lip seal OD and bore. For metal OD radial lip seals, a maximum bore finish of approximately 100 micro-inches (2.5 micro-meters) should be maintained to avoid leakage.

For rubber OD radial lip seals, a maximum bore finish of approximately 150 micro-inches (3.7 micro-meters) should be maintained to avoid leakage. Rubber will conform to the housing roughness and allows the rubber OD radial lip seal to function with a rougher finish.

BORE HARDNESS

No specific hardness is recommended here. However, bore hardness should be high enough to maintain interference with the seal's outside diameter after it is installed. If the bore is too soft and a seal is installed, the material in the bore will likely be abraded away, allowing the seal to be installed, but resulting in a reduced interference fit with the bore due to the abraded material.

BORE CHAMFER AND DEPTH

The bore should always have a burr free lead in chamfer to allow for problem free installation of the radial shaft seal. The inside corner should have a maximum radius of 0.03" (0.8mm).

SEAL DESIGN

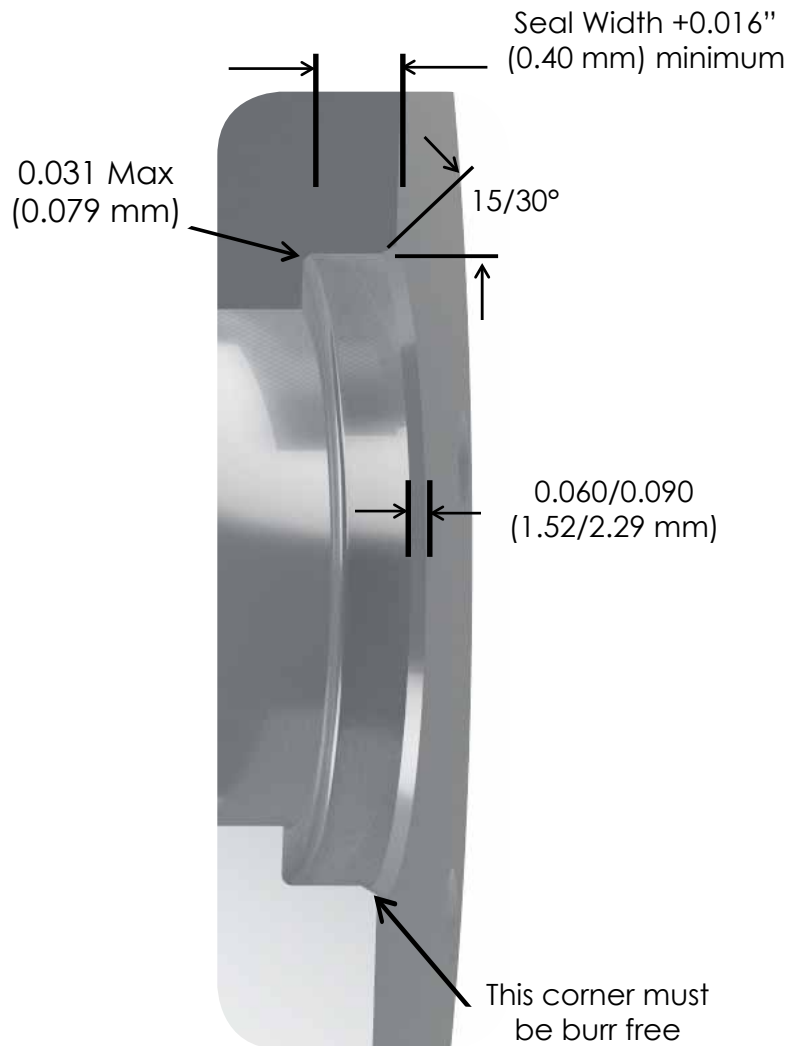

Bore Chamfer.

Should always have a burr free lead-in chamfer to allow for problem free installation of the seal.

BORE TOLERANCE

The interference between the radial shaft seal and bore is controlled by the bore and seal OD tolerance. A seal's press-fit is designed according to the following standard.

SEAL DESIGN

Bore Diameter (inches)	Tolerance
Up to and including 2.000	± 0.001
2.001 to 3.000	± 0.001
3.001 to 5.000	± 0.0015
5.001 to 7.000	± 0.0015
7.001 to 12.000	± 0.002
12.001 to 20.000	$+0.002/-0.004$

Bore Diameter (millimeters)	Tolerance
Over 6 to 10	$+0.022/-0.000$
Over 10 to 18	$+0.027/-0.000$
Over 18 to 30	$+0.033/-0.000$
Over 30 to 50	$+0.039/-0.000$
Over 50 to 80	$+0.046/-0.000$
Over 80 to 120	$+0.054/-0.000$
Over 120 to 180	$+0.063/-0.000$
Over 180 to 250	$+0.072/-0.000$
Over 250 to 315	$+0.081/-0.000$
Over 315 to 400	$+0.089/-0.000$
Over 400 to 500	$+0.097/-0.000$

RADIAL SHAFT SEAL INSPECTION TOLERANCES

Radial Shaft Seal Width Tolerance		
Units	Width Range	Tolerance
Inches	All	+0.015/-0.015
Millimeters	Up to 10	+0.20/-0.20
Millimeters	Over 10	+0.30/-0.30

SEAL DESIGN

Radial Shaft Seal Press Fit Allowance (millimeter)			
Bore Dia. (millimeters)	Metal Case	Rubber Covered Case	Permissible Eccentricity
Up to 50.0	+0.20/+0.10	+0.30/+0.15	0.25
50.1 to 80.0	+0.23/+0.13	+0.35/+0.20	0.35
80.1 to 120.0	+0.25/+0.15	+0.35/+0.20	0.50
120.1 to 180.0	+0.28/+0.18	+0.45/+0.25	0.65
180.1 to 300.0	+0.30/+0.20	+0.45/+0.25	0.80
300.1 to 500.0	+0.35/+0.23	+0.55/+0.30	1.00

Radial Shaft Seal Press Fit Allowance (inch)				
Bore Dia. (inches)	Press-fit Allowance		Tolerance	
	Metal Case	Rubber Covered Case	Metal Case	Rubber Covered Case
Up to 1.000	+0.004	+0.006	+0.002/-0.002	+0.003/-0.003
1.001 to 2.000	+0.004	+0.007	+0.002/-0.002	+0.003/-0.003
2.001 to 3.000	+0.004	+0.008	+0.002/-0.002	+0.003/-0.003
3.001 to 4.000	+0.005	+0.010	+0.002/-0.002	+0.004/-0.004
4.001 to 6.000	+0.005	+0.010	+0.003/-0.002	+0.004/-0.004
6.001 to 8.000	+0.006	+0.010	+0.003/-0.002	+0.004/-0.004
8.001 to 10.000	+0.008	+0.010	+0.004/-0.002	+0.004/-0.004
10.001 to 20.000	+0.008	+0.010	+0.006/-0.002	+0.004/-0.004

PROFILES

ESP International has created an organized Profile Selection Matrix that is customer friendly and easy to understand. Although it helps to be rehearsed in how system sealing parameters can affect lip and OD styles it is not required. To fully utilize this section a brief explanation is needed to provide instruction and explanation of its intended use.

The Profile Matrix is designed in rows and columns based on lip and case type designations. When moving from left to right the lip type remains constant as the case options change. In a similar manner, moving up and down reveals different lip options. The “type” designation and description are at the beginning of each column and row. These descriptions are intended to provide general usage information to aid in the selection process. For applications with limited profile choices the matrix has been reduced to single row format. If a profile option does not appear in the matrix please contact ESP International.

Various Operation Tables are placed after the Profile Matrix to help further determine the appropriate profile for an application. These tables can be used before and after profile selection. When using before profile selection, the type of lip style can be narrowed and help determine which profiles are designed to operate under the applications conditions.

After a profile has been selected this table should be consulted to reaffirm proper selection. For parameters outside the ranges given for operation please contact ESP International.

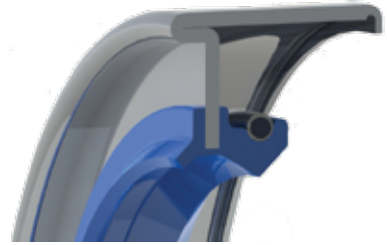











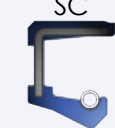





















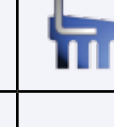

Profiles.

If a profile option does not appear in the matrix please contact ESP International. Custom solutions can be provided upon request.

PROFILE MATRIX

GENERAL APPLICATIONS

		Cast or steel housing where structural rigidity is required	Cast or steel housing	Soft alloy or plastic housing or as replacements if housing surface is damaged	Soft alloy or plastic housing, ribs reduce installation forces	Steel or soft alloy housing, provides metal to metal fit and sealing ability of rubber, reducing springback
	Case Type	A2 Dual metal case, metal OD	B2 Single metal case, metal OD	C Rubber coated case	G Rubber coated case with ribs added to OD	BC Single metal case, metal OD, with half/half design
	Lip Type					
General standard pressure fluid sealing and severe grease sealing	S - Single spring loaded lip					
General standard pressure fluid sealing and severe grease sealing with light duty exclusion of foreign materials	T - Single spring loaded lip with dust lip					
General standard pressure grease and viscous fluid sealing	V - Single lip					
General standard pressure grease and viscous fluid sealing with light duty exclusion of foreign materials	K - Single lip with dust lip					
General fluid sealing and severe grease sealing where separation of two fluids is required	D - Dual spring loaded lips					
General standard pressure grease retention with heavy duty exclusion of mud and water	U - Triple sealing lip					
General standard pressure grease retention with heavy duty exclusion of mud and water and sealing element contacting bore	OU - OD triple sealing lips					

PROFILES

N STYLE

General medium pressure fluid sealing applications (50-100 PSI, 3.4-6.9 Bar max), seals are designed for soft alloy or steel housing.

PROFILES

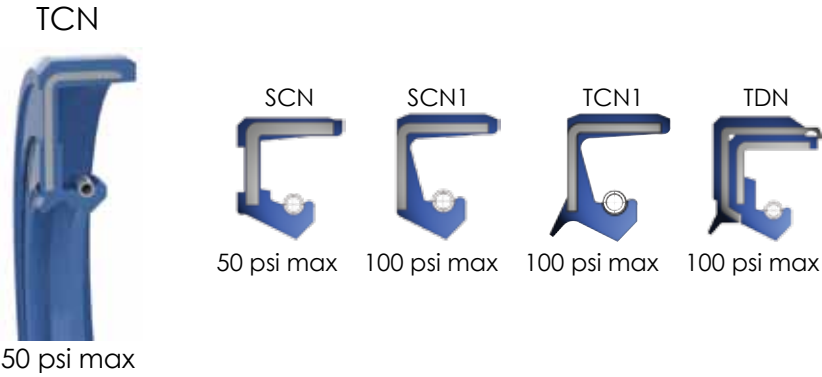

RECOMMENDED OPERATING CONDITIONS			
Maximum shaft dynamic run-out (DRO)		RPM	0-2000
		TIR	0.003" 0.08 mm
Maximum shaft to bore misalignment (STBM)		FPM (MPM)	0-2000 (0-610)
		STBM	0.005" 0.13 mm
Maximum shaft surface speed	RPM for given shaft size	1" (25.4 mm)	7639
		2" (50.8 mm)	3820
		3" (76.2 mm)	2546
	FPM (MPM)		2000 (610)

4 STYLE

General standard pressure applications where linear movement is prevalent, seals with metal OD are designed for cast or steel housing while rubber OD seals are for soft alloy or plastic housing.

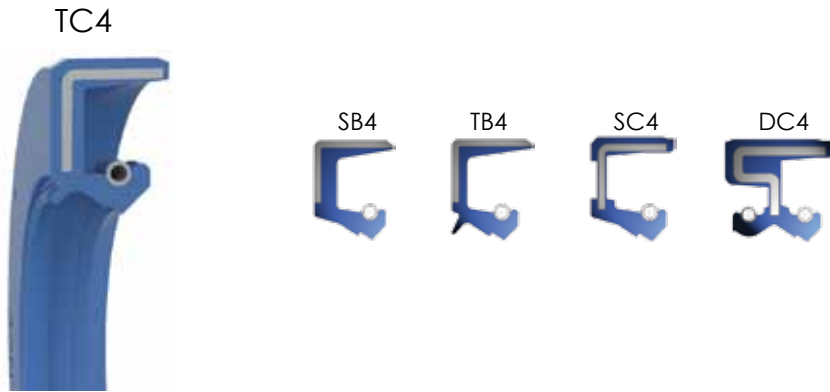

PROFILES

RECOMMENDED OPERATING CONDITIONS				
Maximum shaft dynamic runout (DRO)	RPM	0-1000	1000-2500	2500-4500
	TIR	0.020" 0.51 mm	0.015" 0.38 mm	0.010" 0.25 mm
Maximum shaft to bore misalignment (STBM)	FPM (MPM)	0-1000 (0-305)	1000-3600 (305-1097)	
	STBM	0.015" 0.38 mm	0.010" 0.25 mm	
Maximum pressure	FPM (MPM)	0-1000 (0-305)	1000-2000 (305-609)	2000-3600 (610-1097)
	PSI (BAR)	10 (0.69)	5 (0.34)	0 (0)
Maximum shaft surface speed	RPM for given shaft size	1" (25.4 mm)	13751	
		2" (50.8 mm)	6875	
		3" (76.2 mm)	4584	
	FPM (MPM)	3600 (1097)		

8-9 STYLE

General standard pressure applications, lip on outside face is designed to act as rotary axial face seal, seals with metal OD are design for cast or steel housing while rubber OD seals are for soft alloy housing.

TB29

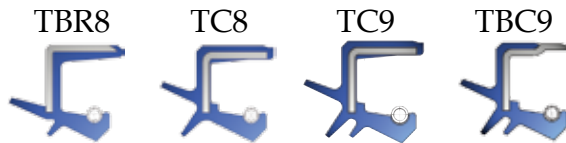

PROFILES

RECOMMENDED OPERATING CONDITIONS				
Maximum shaft dynamic run-out (DRO)	RPM	0-1000	1000-2500	2500-4500
	TIR	0.020" 0.51 mm	0.015" 0.38 mm	0.010" 0.25 mm
Maximum shaft to bore misalignment (STBM)	FPM (MPM)	0-1000 (0-305)	1000-3600 (305-1097)	
	STBM	0.015" 0.38 mm	0.010" 0.25 mm	
Maximum pressure	FPM (MPM)	0-1000 (0-305)	1000-2000 (305-609)	2000-3600 (610-1097)
	PSI (BAR)	10 (0.69)	5 (0.34)	0 (0)
Maximum shaft surface speed	RPM for given shaft size	1" (25.4 mm)	13751	
		2" (50.8 mm)	6875	
		3" (76.2 mm)	4584	
	FPM (MPM)	3600 (1097)		

R STYLE

General standard pressure axial face seal for heavy duty foreign material exclusion. Metal case might be used to protect the elastomer from being destroyed.

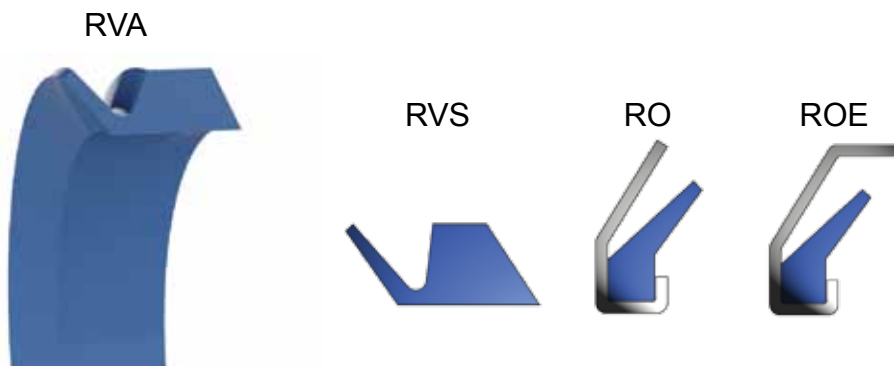

PROFILES

RECOMMENDED OPERATING CONDITIONS				
Maximum shaft dynamic run-out (DRO)	RPM	0-1000	1000-2500	2500-4500
	TIR	0.020" 0.51 mm	0.015" 0.38 mm	0.010" 0.25 mm
Maximum shaft to bore misalignment (STBM)	FPM (MPM)	0-1000 (0-305)	1000-3600 (305-1097)	
	STBM	0.015" 0.38 mm	0.010" 0.25 mm	
Maximum pressure	FPM (MPM)	0-1000 (0-305)	1000-2000 (305-609)	2000-3600 (610-1097)
	PSI (BAR)	10 (0.69)	5 (0.34)	0 (0)
Maximum shaft surface speed	RPM for given shaft size	1" (25.4 mm)	13751	
		2" (50.8 mm)	6875	
		3" (76.2 mm)	4584	
	FPM (MPM)	3600 (1097)		

C STYLE

General standard pressure fluid sealing and severe grease sealing with light duty exclusion of foreign materials, designed for applications where shaft eccentricity is excessive (0.060", 1.5 mm max).

TBCC

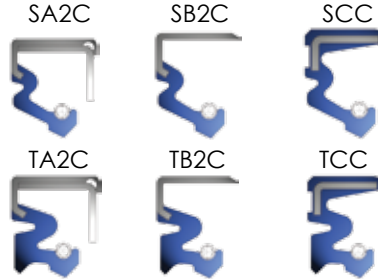

PROFILES

RECOMMENDED OPERATING CONDITIONS				
Maximum shaft dynamic run-out (DRO)	RPM	0-1000	1000-2500	2500-4500
	TIR	0.050" 0.51 mm	0.030" 0.38 mm	0.020" 0.25 mm
Maximum shaft to bore misalignment (STBM)	FPM (MPM)	0-1000 (0-305)	1000-3600 (305-1097)	
	STBM	0.040" 0.38 mm	0.020" 0.25 mm	
Maximum pressure	FPM (MPM)	0-1000 (0-305)	1000-2000 (305-609)	2000-3600 (610-1097)
	PSI (BAR)	10 (0.69)	5 (0.34)	0 (0)
Maximum shaft surface speed	RPM for given shaft size	1" (25.4 mm)	13751	
		2" (50.8 mm)	6875	
		3" (76.2 mm)	4584	
	FPM (MPM)	3600 (1097)		

E STYLE

Solid cap (no center hole) for sealing additional shaft location holes.

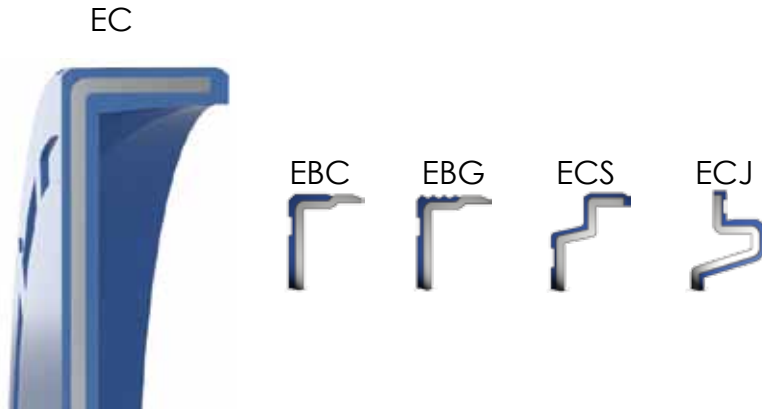

PROFILES

RECOMMENDED OPERATING CONDITIONS		
Maximum pressure	PSI (BAR)	20 (1.4)

V STYLE

Single lip without spring for general standard pressure grease and viscous fluid sealing, install with lip facing to the air side for maximum dirt exclusion, not typically recommended for oil retention.

VB2

PROFILES

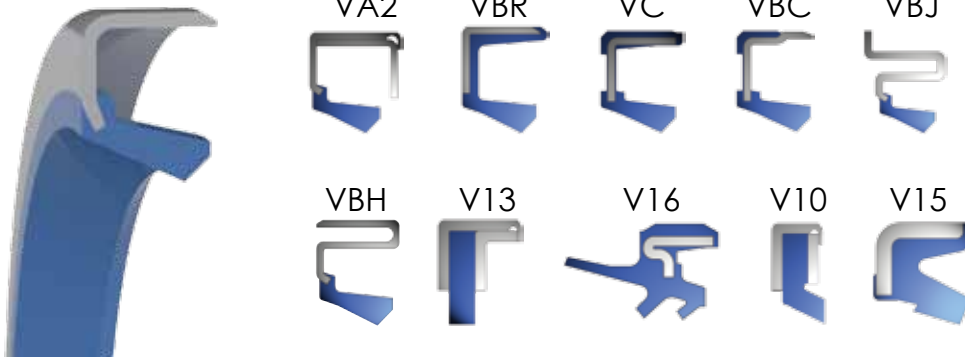

RECOMMENDED OPERATING CONDITIONS			
Maximum shaft dynamic run-out (DRO)	RPM	0-2000	
	TIR	0.003" 0.08 mm	
Maximum shaft to bore misalignment (STBM)	FPM (MPM)	0-2000 (0-610)	
	STBM	0.005" 0.13 mm	
Maximum pressure	FPM (MPM)	0-2000 (0-610)	
	PSI (BAR)	3 (0.21)	
Maximum shaft surface speed	RPM for given shaft size	1" (25.4 mm)	7639
		2" (50.8 mm)	3820
		3" (76.2 mm)	2546
	FPM (MPM)		2000 (610)

K STYLE

Dual lip without spring for general standard pressure grease and viscous fluid sealing, secondary lip is designed for light duty exclusion of foreign materials, not typically recommended for oil retention.

KB2

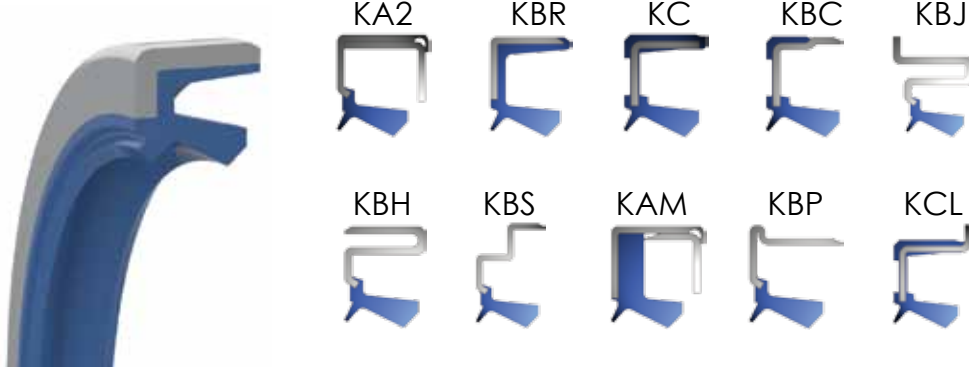

PROFILES

RECOMMENDED OPERATING CONDITIONS			
Maximum shaft dynamic run-out (DRO)	RPM	0-2000	
	TIR	0.003" 0.08 mm	
Maximum shaft to bore misalignment (STBM)	FPM (MPM)	0-2000 (0-610)	
	STBM	0.005" 0.13 mm	
Maximum pressure	FPM (MPM)	0-2000 (0-610)	
	PSI (BAR)	3 (0.21)	
Maximum shaft surface speed	RPM for given shaft size	1" (25.4 mm)	7639
		2" (50.8 mm)	3820
		3" (76.2 mm)	2546
	FPM (MPM)	2000 (610)	

S STYLE

Single spring loaded lip for general standard pressure fluid sealing and severe grease sealing applications.

SB2

PROFILES

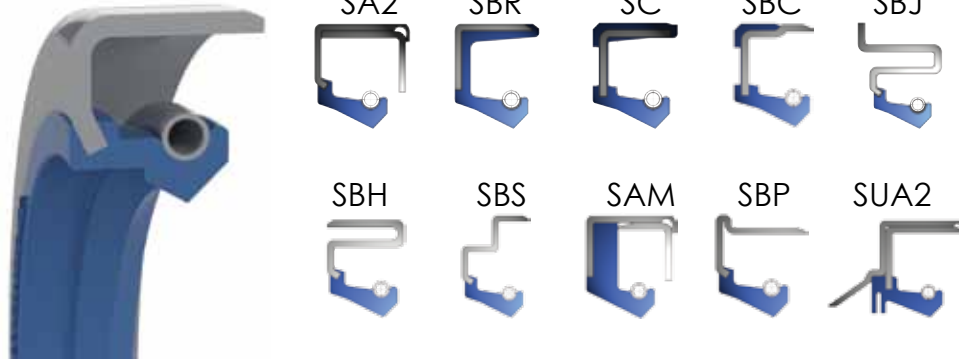

RECOMMENDED OPERATING CONDITIONS				
Maximum shaft dynamic run-out (DRO)	RPM	0-1000	1000-2500	2500-4500
	TIR	0.020" 0.51 mm	0.015" 0.38 mm	0.010" 0.25 mm
Maximum shaft to bore misalignment (STBM)	FPM (MPM)	0-1000 (0-305)	1000-3600 (305-1097)	
	STBM	0.015" 0.38 mm	0.010" 0.25 mm	
Maximum pressure	FPM (MPM)	0-1000 (0-305)	1000-2000 (305-609)	2000-3600 (610-1097)
	PSI (BAR)	10 (0.69)	5 (0.34)	0 (0)
Maximum shaft surface speed	RPM for given shaft size	1" (25.4 mm)	13751	
		2" (50.8 mm)	6875	
		3" (76.2 mm)	4584	
	FPM (MPM)	3600 (1097)		

T STYLE

Single spring loaded lip with dust lip for general standard pressure fluid sealing and severe grease sealing applications, secondary lip is designed for light duty exclusion of foreign materials.

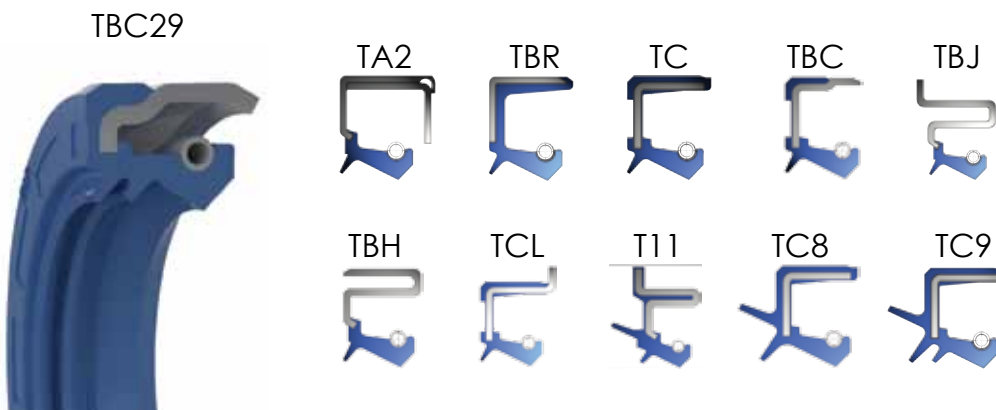

PROFILES

RECOMMENDED OPERATING CONDITIONS				
Maximum shaft dynamic run-out (DRO)	RPM	0-1000	1000-2500	2500-4500
	TIR	0.020" 0.51 mm	0.015" 0.38 mm	0.010" 0.25 mm
Maximum shaft to bore misalignment (STBM)	FPM (MPM)	0-1000 (0-305)	1000-3600 (305-1097)	
	STBM	0.015" 0.38 mm	0.010" 0.25 mm	
Maximum pressure	FPM (MPM)	0-1000 (0-305)	1000-2000 (305-609)	2000-3600 (610-1097)
	PSI (BAR)	10 (0.69)	5 (0.34)	0 (0)
Maximum shaft surface speed	RPM for given shaft size	1" (25.4 mm)	13751	
		2" (50.8 mm)	6875	
		3" (76.2 mm)	4584	
	FPM (MPM)	3600 (1097)		

D STYLE

Dual spring loaded lips, typically used to separate two fluids but can also be used in high contamination situations to keep out foreign materials and to retain fluid.

PROFILES

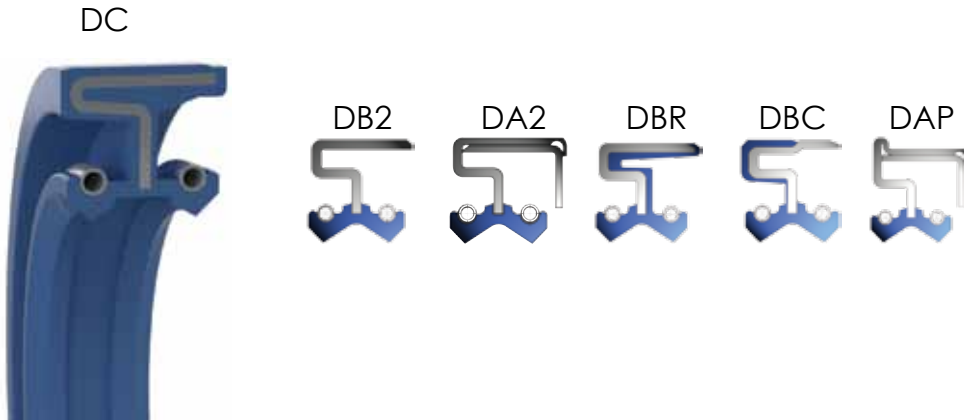

RECOMMENDED OPERATING CONDITIONS			
Maximum shaft dynamic run-out (DRO)	RPM	0-1000	1000-2000
	TIR	0.010" 0.25 mm	0.005" 0.13 mm
Maximum shaft to bore misalignment (STBM)	FPM (MPM)	0-1000 (0-305)	1000-2000 (305-610)
	STBM	0.010" 0.25 mm	0.005" 0.13 mm
Maximum pressure	FPM (MPM)	0-1000 (0-305)	1000-2000 (305-609)
	PSI (BAR)	10 (0.69)	5 (0.34)
Maximum shaft surface speed	RPM for given shaft size	1" (25.4 mm)	7639
		2" (50.8 mm)	3820
		3" (76.2 mm)	2546
	FPM (MPM)		2000 (610)

U STYLE

Triple flat lips for general standard pressure grease retention with heavy duty exclusion of mud and water, commonly used in agricultural equipment.

UB2

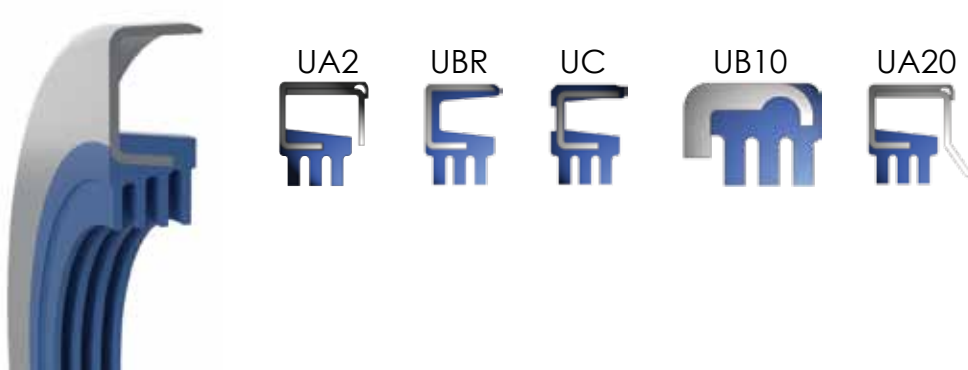

RECOMMENDED OPERATING CONDITIONS			
Maximum shaft dynamic run-out (DRO)	RPM	0-800	
	TIR	0.003" 0.08 mm	
Maximum shaft to bore misalignment (STBM)	FPM (MPM)	0-500 (0-152)	
	STBM	0.015" 0.38 mm	
Maximum pressure	FPM (MPM)	0-500 (0-152)	
	PSI (BAR)	3 (0.21)	
Maximum shaft surface speed	RPM for given shaft size	1" (25.4 mm)	1910
		2" (50.8 mm)	955
		3" (76.2 mm)	637
	FPM (MPM)		500 (152)

OU STYLE

Triple flat lips for general standard pressure grease retention with heavy duty exclusion of mud and water, commonly used in agricultural equipment.

OUB2

PROFILES



RECOMMENDED OPERATING CONDITIONS			
Maximum shaft dynamic run-out (DRO)	RPM	0-800	
	TIR	0.003" 0.08 mm	
Maximum shaft to bore misalignment (STBM)	FPM (MPM)	0-500 (0-152)	
	STBM	0.015" 0.38 mm	
Maximum pressure	FPM (MPM)	0-500 (0-152)	
	PSI (BAR)	3 (0.21)	
Maximum shaft surface speed	RPM for given shaft size	1" (25.4 mm)	1910
		2" (50.8 mm)	955
		3" (76.2 mm)	637
	FPM (MPM)	500 (152)	

O STYLE

External lip seals designed to press-fit on shaft or spindle with sealing element contacting bore, all may be used with lip facing outward to exclude dirt and allow purging.

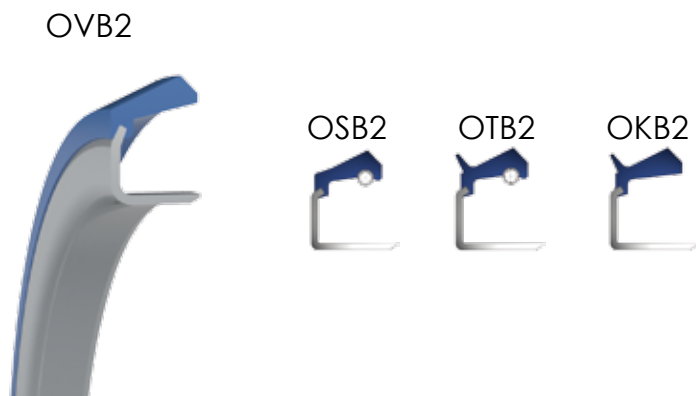

PROFILES

RECOMMENDED OPERATING CONDITIONS					
Maximum shaft dynamic run-out (DRO)		Oil Lip			Grease Lip
	RPM	0-1000	1000-2500	2500-4500	0-2000
	TIR	0.020" 0.51 mm	0.015" 0.38 mm	0.010" 0.25 mm	0.003" 0.08 mm
Maximum shaft to bore misalignment (STBM)	FPM (MPM)	0-1000 (0-305)	1000-3600 (305-1097)		0-1000 (0-610)
	STBM	0.015" 0.38 mm	0.010" 0.25 mm		0.005" 0.13 mm
Maximum pressure	FPM (MPM)	0-1000 (0-305)	1000-2000 (305-609)	2000-3600 (610-1097)	0-2000 (0-610)
	PSI (BAR)	10 (0.69)	5 (0.34)	0 (0)	3 (0.21)
Maximum shaft surface speed	RPM for given shaft size	1" (25.4 mm)	13751		7639
		2" (50.8 mm)	6875		3820
		3" (76.2 mm)	4584		2546
	FPM (MPM)	3600 (1097)		2000 (610)	

WP STYLE

This style of lip is used for scraping and wiping in hydraulic and pneumatic cylinder applications.

WPB

PROFILES

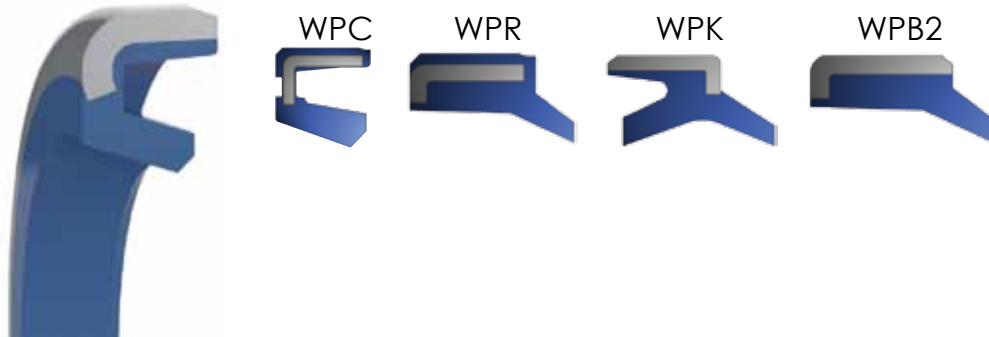

RECOMMENDED OPERATING CONDITIONS		
Maximum shaft to bore misalignment (STBM)	STBM	0.008" 0.20 mm
	FPM (MPM)	0-200 (0-60)
Maximum pressure	PSI (BAR)	4 (0.28)
	FPM (MPM)	0-200 (0-60)
Maximum Shaft Surface Speed	FPM (MPM)	Linear velocity 200 (60) maximum stroke length 78" (1.98 m)

TSL STYLE

General standard pressure fluid sealing and severe grease sealing, seals are designed for exclusion of foreign materials, usually used in harsh environments where seals will see large amount of dirt and debris.

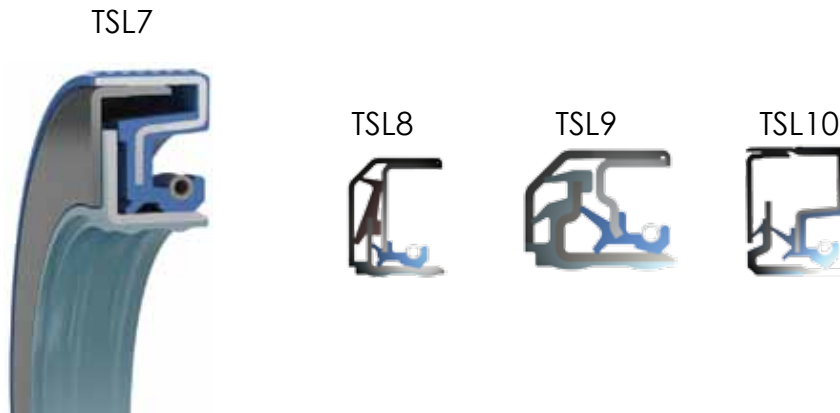

PROFILES

RECOMMENDED OPERATING CONDITIONS			
Maximum shaft dynamic run-out (DRO)	TIR	0.010" 0.08 mm	
	RPM	0-2500	
Maximum shaft to bore misalignment (STBM)	STBM	0.010" 0.25 mm	
	FPM (MPM)	0-500 (0-152)	
Maximum pressure	PSI (BAR)	10 (0.69)	
	FPM (MPM)	0-500 (0-152)	
Maximum shaft surface speed	RPM for given shaft size	1" (25.4 mm)	1910
		2" (50.8 mm)	955
		3" (76.2 mm)	637
	FPM (MPM)		500 (152)

INSTALLATION DIRECTION

The installation direction determines the primary task of the seal.

It can be installed facing the air side, this is the common way to use a seal, this way the seal function is to keep the oil inside of the application.

If the function of the seal is to keep contamination out it may be installed facing the oil side. In some applications where both function are required two seals may be used, for specific applications please contact ESP International.

PROFILES

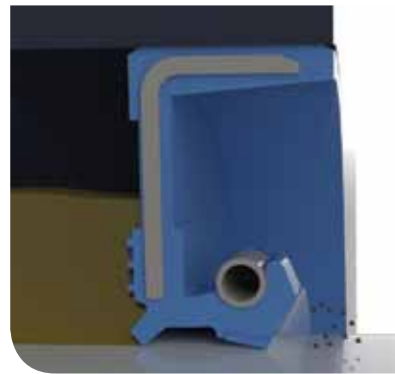
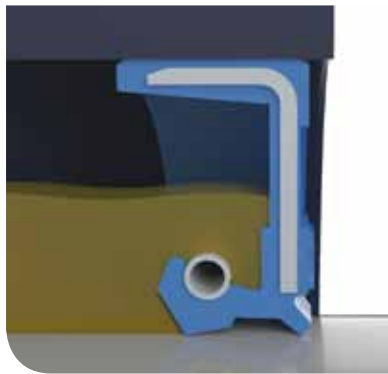

Installation direction.

The installation direction determines the primary concern of the seal, it can be to keep the oil inside or to keep the contamination out.

HYDRODYNAMIC AID DESIGNS

Hydrodynamic aids can provide vital sealing assistance for a given lip style. This section provides a 2-D view of the air side angle with an aid style designation. The use of a hydrodynamic aid is represented by placing an “H” in front of the radial shaft seal profile designation. If a “TC” profile utilizes a hydrodynamic aid the designation would be “HTC”. More specifically, the aid style will be attached to the end of the profile designation. For a “U5” style aid, in the above example, the complete profile designation would be “HTCU5”.

For example, the “L” style aid is a series of molded ribs located on the air side at an angle of 15° to 20° to the circumferential contact width.

PARAMETER	HYDRODYNAMIC AID
Shaft only rotates in clockwise direction	Type “R”
Shaft only rotates in counter-clockwise direction	Type “L”
Shaft rotates in both clockwise and counter-clockwise direction	Type “U”

PROFILES

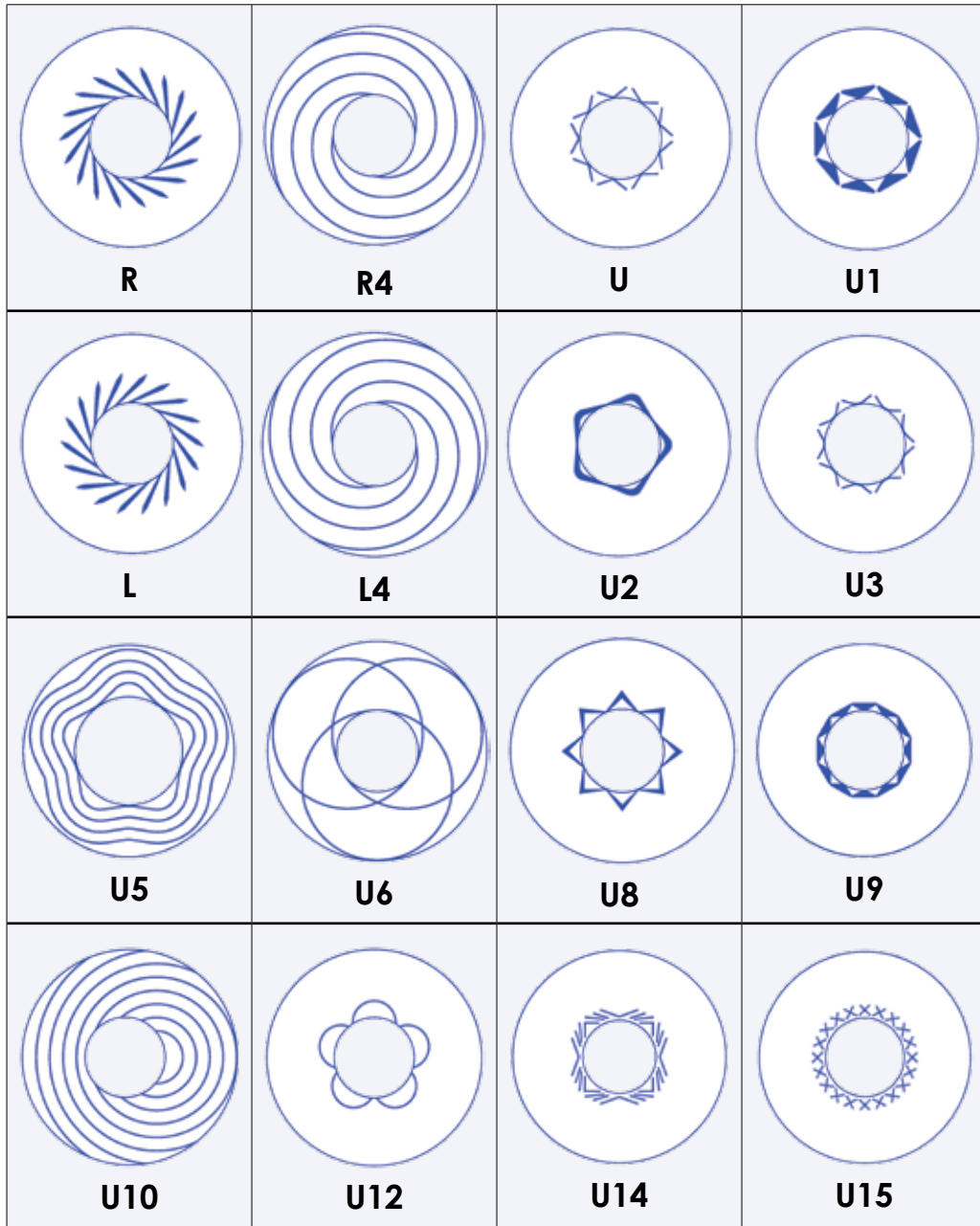

For more information on hydrodynamic aids contact ESP International



Request for Quotation

ESP International
 5920 Dry Creek Lane NE
 Cedar Rapids, IA 52402
 Ph: 319-393-4310
 Fax: 319-393-5327
 www.espint.com

Company:	Date:
Contact Name:	E-Mail:
Phone:	Fax:

Dim	Description	Value
SD	Shaft Diameter	
BD	Bore Diameter	
L	Bore Depth	
SA	Shaft Chamfer Angle	
SCL	Shaft Chamfer Length	
BA	Bore Chamfer Angle	
BCL	Bore Chamfer Length	
W	Seal Width	

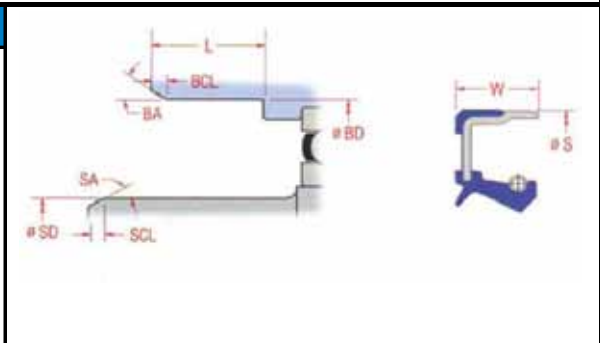

Shaft

Horizontal Vertical

Material:

Hardness:

Surface Finish:

Lead Angle:

Dynamic Runout:

Shaft Offset:

Bore

Straight Counterbore

Material:

Hardness:

Surface Finish:

Chamfer: Yes No

Shaft Motion

Rotating Normal Max

RPM:

Shaft Speed (ft / min) **

1 2 3 4 5

(0-500) (500-750) (750-1750) (1750-4000) (4000-up)

Reciprocating Oscillating

Stroke Length: Degrees of Arc

Cycle / Min: Normal Max

Contamination Level **

1 2 3 4 5

Particle Type:

% of Exposure:

% Submerged:

Temperature **

F C

Sump: Underlip: Outside:

Pressure (PSI) **

Standard Med/Low Med High

(0-10) (10-50) (500-1000) (< 1000)

Fluid / Lubrication

Grease Oil

Assembly

Removal: Rare Often

Space Restrictions: Yes No

Pilot Gap: ** Yes No

Shaft Installation Direction

Installation Direction into Bore

Type:

VI Index:

Sump Fill Level:

Application Description:

Usage **

Continuous Intermittent

Cycle Time: 1 2 3 4 5

Down Time: 1 2 3 4 5

MANUFACTURING PROCESS

Each radial shaft seal is made for an application, which uses a particular fluid, runs at a pre-determined speed, has certain temperatures and pressures, and is in a specific environment. Because of this the manufacturing process of each type of seal may have some additional steps or modifications.

In general the seal consists of three main components, a rubber portion, a metal can and a spring. Of which, the rubber and can are bonded together and the spring is assembled to the rubber portion.

The elastomer that is used in the seal is called a compound and consists of a variety of different materials (base polymer, fillers, plasticizers, vulcanizing agents, accelerators, cure activator, inhibitors, anti-degradant, pigments). The ingredients for the compound is placed in a mixing machine, where the rotating rotors mix the ingredients creating a homogeneous substance. Because the movement of the rotor creates high temperatures the rotors need to have an internal refrigerant system to avoid the vulcanization of the rubber during this step.

After the compound is homogeneous, it is sent to an open mill, where two cylinders rotate in opposite directions. The speed of the cylinders are different, that way the rubber builds onto one of the cylinders, creating a rubber sheet. The cylinder temperature is also controlled so that it does not exceed the vulcanization temperature of the compound.



Mixing Machine.

The rotating rotors mix the ingredients creating a homogeneous substance.



Open Mill.

After the compound is homogeneous, it is sent to the open mill, where two cylinders rotate in opposite direction.

MANUFACTURING PROCESS



Stamping Machine.

The metal sheet is placed on the top of the bottom plate, and the upper die comes down and presses the die into the metal sheet.

Before the rubber moves to the molding department, it is inspected to make sure that it meets the minimum requirements for the material. Various tests are performed to evaluate, hardness, tensile strength, elongation, compression set. The compound may also be tested to those criteria after it has been immersed in a fluid or heated in air. After the batch has been qualified it moves to the molding department and is ready for use.

The metal case is typically manufactured from low carbon steel or stainless steel. Typically metal strip is purchased and the case is formed from a stamping process.

To avoid oxidation in the metal, the parts are coated shortly after stamping. After the stamping process the case is cleaned to remove any metal shavings, grease and dirt. When the case is clean they are coated with zinc phosphate. This coating protects against corrosion and helps improve the surface for later bonding to the elastomer.

After the plated parts have dried, a primer and bonding agent are applied to the case. The bonding agent is required in order for the rubber to bond to the metal during molding. The primer and bonding agent can be applied with a spray gun, a brush or by dipping.

MANUFACTURING PROCESS

The bonding of the case and rubber occurs during vulcanization. There are three methods that can be used to mold radial shaft seals:

- Compression molding: The metal case is placed into the lower part of the mold and the pre cut shape of the compound (or preform) is set on top of the case. The upper and lower molds, which contains the shape of the seal, is heated to the vulcanization temperature of the compound. The upper mold is pressed down, forcing the compound to flow into the areas of the mold. After a specific period of time the compound is fully cured, the mold is then opened and the parts are removed.

MANUFACTURING PROCESS



Compression Molding

The upper mold is pressed down, forcing the compound into the areas of the mold

- Transfer molding: Again the metal case is placed into the lower part of the mold and the upper and lower molds are heated to the vulcanization temperature. The preform in transfer molding is placed into a transfer pot and not in the mold itself. The mold is then closed and the elastomer is transferred into the mold via the later compression of the transfer pot. This type of molding presents less flash in the part than compression molding.



Transfer Molding

The preform is placed into the transfer pot and not into the mold itself

MANUFACTURING PROCESS

- **Injection molding:** In this type of molding the compound is poured into a barrel, where it is heated at higher temperatures than the compression or transfer molding. This is done because the distance to the mold is generally longer. The barrel contains a screw that moves the compound forward while it is being heated. The compound is then forced into the mold through a nozzle. Once the mold is full the screw stops moving, ceasing the flow into the mold. After the elastomer has cured the mold opens and the parts are removed.



Injection Molding

The compound is forced into the mold through a nozzle

After the rubber and can are bonded together they are transferred to the trimming machine; there are different kinds of machines for trimming a seal, the main difference is the way the seal is held down while is being trimmed, some use a vacuum and others use a tight fit to a collet. During trimming the seal rotates at a high RPM while knives trim the part.

The spring in a radial shaft seal is manufactured from high carbon steel wire that is placed in a spring coiling machine.

The seals and springs are inserted into the seal either in an insertion machine or by hand. The seals may go through a machine to help orient them properly for assembly of the spring.

After the spring has been loaded the seals may be checked in the same insertion machine or in a checking machine, where a camera will measure the inner diameter of the seal to make sure that the spring was correctly installed.

MANUFACTURING PROCESS

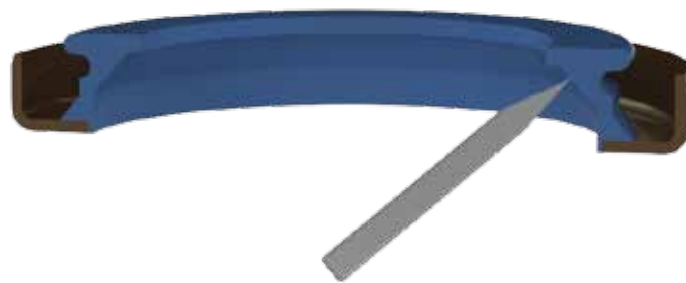

Knife Trimming

During trimming the seal rotates at a high RPM while the knives trim the part.

Some seals require added manufacturing steps. A few of the more common steps are listed below:

- The outside diameter can be ground. Grinding the OD helps to control a tighter tolerance on the OD of the metal portion of the seal.
- OD sealant may be added to the outside diameter. This helps to prevent leaks due to bore imperfections. OD sealant is typically applied to all seals that have metal only OD's, such as a TB2 or VB2 cross section.
- The edge of some seal cases can be rolled to make the installation of the seal easier and prevent seal-cocking during installation
- Seals can also be pre-greased before packaging. The added grease acts as a pre-lubrication for the seal lip and helps to provide initial lubrication to the lip for installation and initial run-in of the lip.

MANUFACTURING PROCESS



Greased Seal.

Grease can be added to some seals to keep the lip lubricated during the break in period.

START

1



ESP engineers work with the customer to design a seal for their application.

2

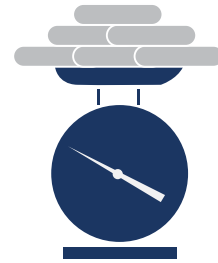

Select and weigh compound ingredients

5



Material is inspected and tested

6

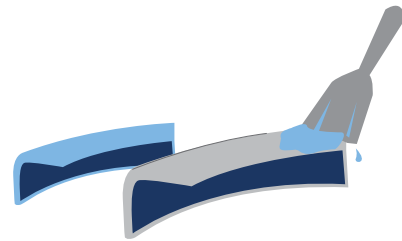

Metal cans are stamped, zinc phosphate coated and a bonding agent is applied

8

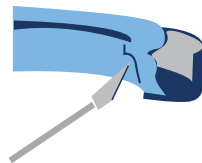

The seals are trimmed as needed

9



Springs are inserted into the seals

12



Sample parts are tested and inspected

13

Parts are packaged and shipped from one of the ESP worldwide locations



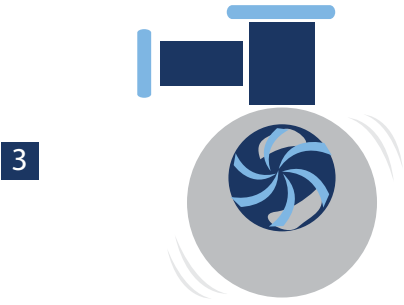

3
Compound is combined in a mixing device

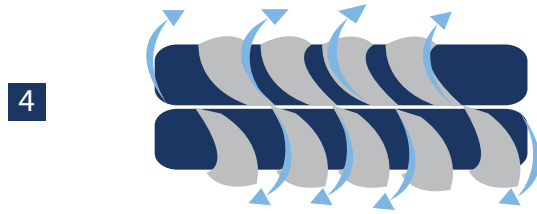

4
The compound is transferred to an open mill

The parts are molded using one of this methods

7



Injection Molding

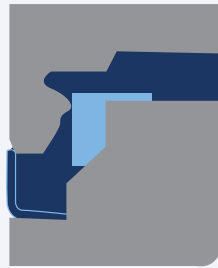

Compression Molding

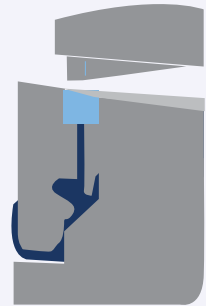

Transfer Molding

10



10
The OD can be ground, OD sealant applied and the edge of the case can be rolled as needed

11



11
Seals are greased as needed

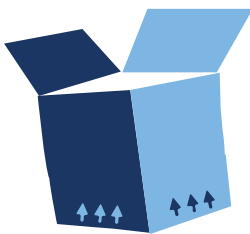

INSTALLATION

The subject of installation represents an area commonly overlooked when selecting a radial shaft seal for an application. Improper installation methods are a major cause of premature seal failure. The most expertly designed and manufactured seal will not function properly if the installation is incorrect.

ALIGNMENTS

There are two areas that need to be checked before installing the seal, the Shaft to Bore Misalignment and the Shaft Run-out.

The shaft to bore misalignment is the deviation of the center axis of the shaft and the receiving bore, if this value is higher than required it will cause an irregular distribution of force around the seal.

Shaft run out or dynamic run out is the distance that the shaft does not rotate around the center axis. At high RPM the shaft sealing surface will run in a different center line than the seal center line, and create a leakage.

INSTALLATION

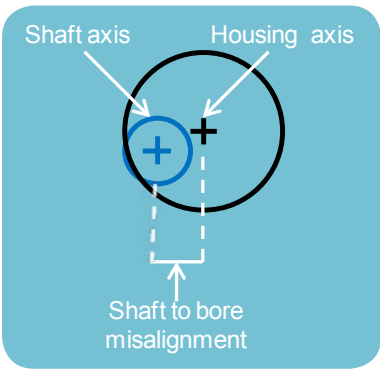
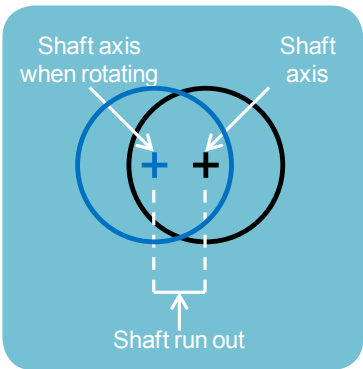

Alignments.
The shaft to bore misalignment and the shaft run-out, need to be checked prior to installation.

PRE-INSTALLATION

Before starting the installation, the seal should be inspected to make sure it does not have any abnormalities or damage.

Even if the seal has a small cut on the OD it can cause the seal to leak. The bore should be also checked to be sure it does not have any scratches or contamination that could affect the seal.

The seal and shaft need to have some level of lubrication, before starting to run, this will protect the lip during the initial break-in. Some seals have grease between the main lip and the dust lip to protect the lip during the break-in period.

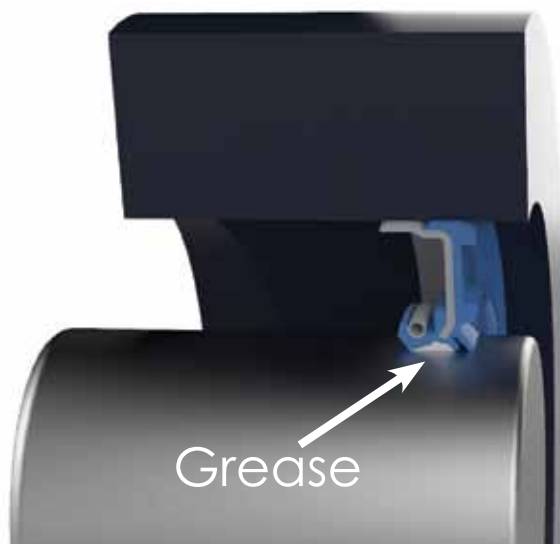

Pre-Installation.

The seal and shaft need to have some level of lubrication before starting to run.

INSTALLATION

INSTALLATION METHODS

An installation tool should always be used when installing a radial shaft seal. The use of a tool improves ease of installation and reduces the possibility of seal cocking (non-perpendicular to shaft). Press-fitting tools should have an outside diameter approximately 0.010" (0.25 mm) smaller than the bore size.

A hydraulic or pneumatic press is advised to supply the necessary force to install the seal.

SEAL COCKING

Cocking can seriously affect the function of the seal. Seal cocking causes one side of the sealing lip to have greater interference with the shaft. This can generate more heat which is harmful for the lip because it can harden and crack. If the cocking is severe the spring may also dislodge from the lip.



Cocked Seal.

Seal cocking causes one side of the sealing lip to have greater interference with the shaft.

INSTALLATION

SPRING BACK

When the OD of a seal is rubber covered, the seal may spring back after it has been installed. The friction between the rubber OD of the seal and the bore can cause the seal to retract from the installation position, after it has been pressed in.

Springback 1: Seal being installed.

When the seal is being installed, it contacts the bottom of the bore.

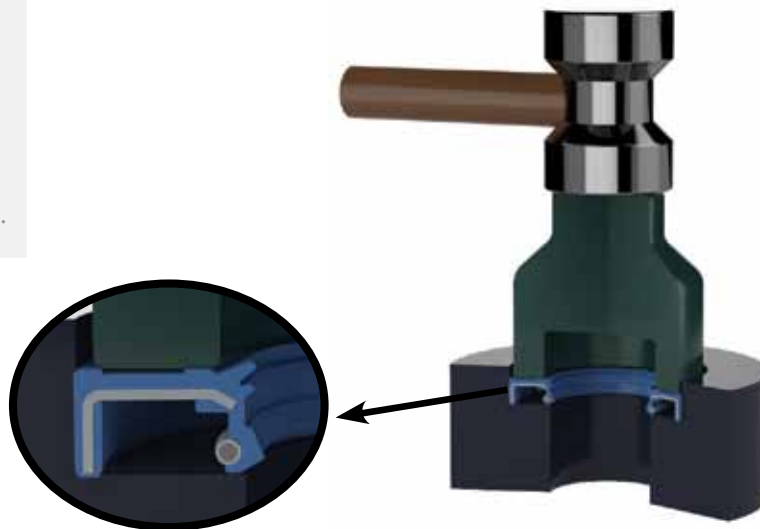

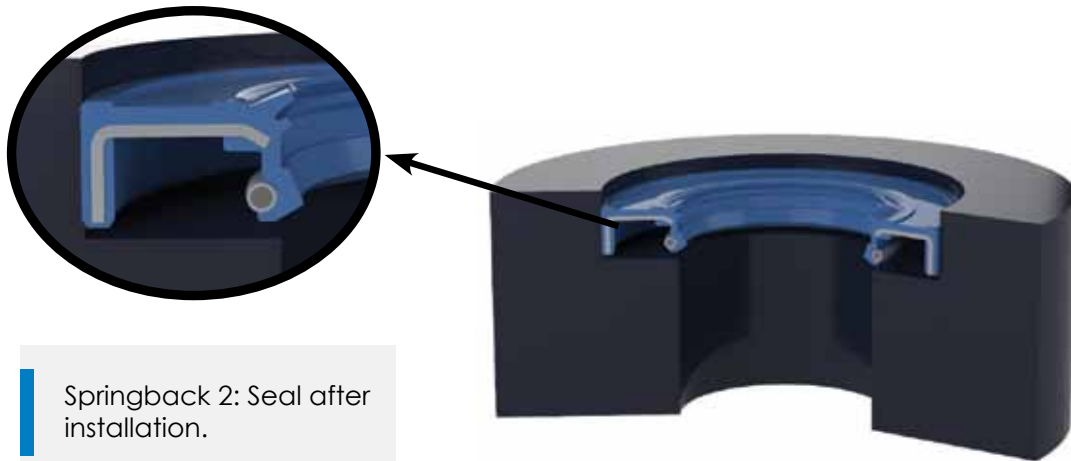

Springback 2: Seal after installation.

After the installation force is removed, the seal will shift slightly away from the bottom of the bore, this effect is called springback.

INSTALLATION

ACCEPTABLE INSTALLATION METHODS

HOUSING SURFACE STOP INSTALLATION

The machined face of the installation tool bottoms on the machined housing face.

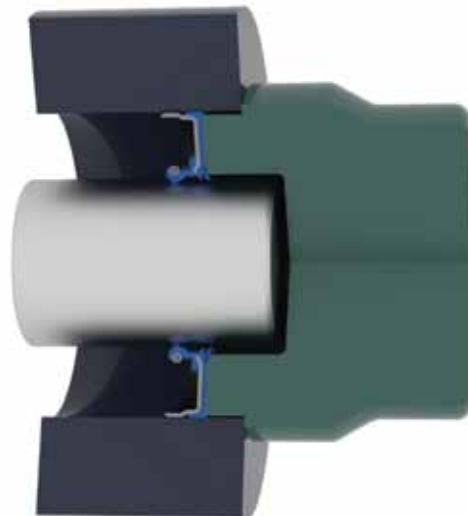

HOUSING STOP INSTALLATION

The seal bottoms on the interior shoulder of the bore.

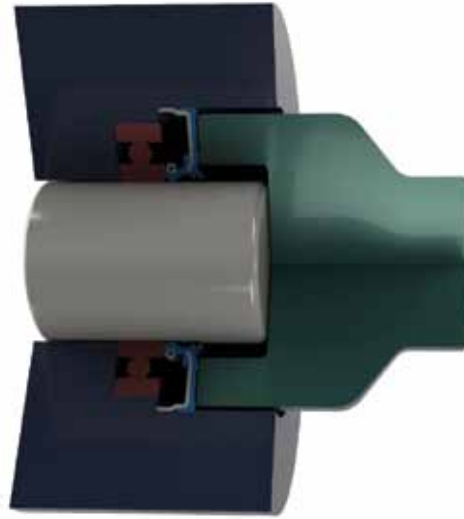

SURFACE STOP INSTALLATION

The installation tool bottoms on the machined housing face.

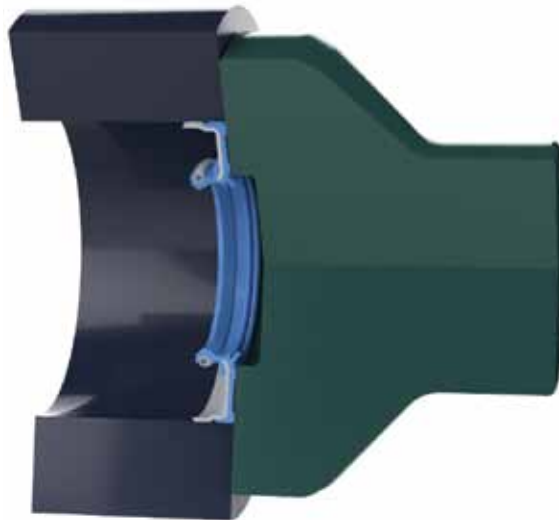

INSTALLATION

INSTALLATION OF SEAL OVER SPLINES

A thin walled lubricated assembly sleeve prevents damage to seal lip from the splines, keyways and unchamfered shafts.

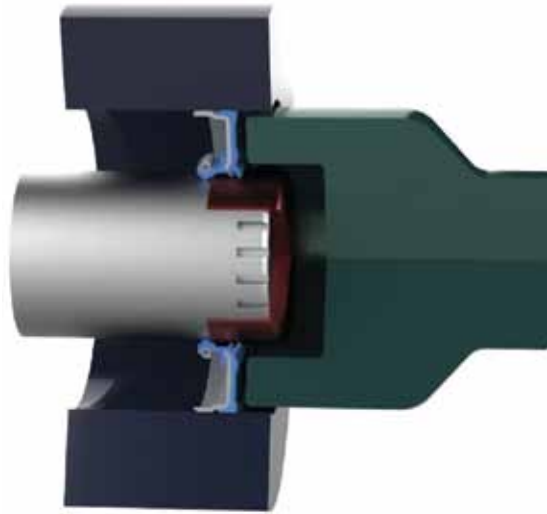

INSTALLATION

STRIKE PLATE INSTALLATION

The face of strike plate bottoms on the machined housing face. Care must be taken to insure proper seal to bore alignment while the seal is being installed.

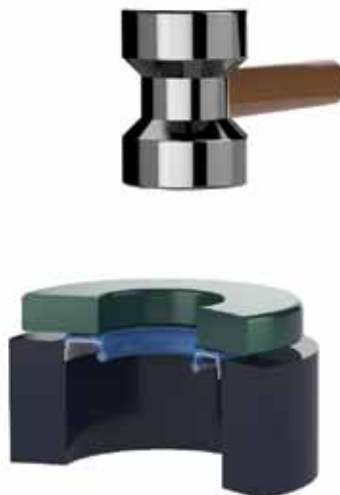

SHAFT STOP INSTALLATION

The installation tool bottoms on the face of the shaft.

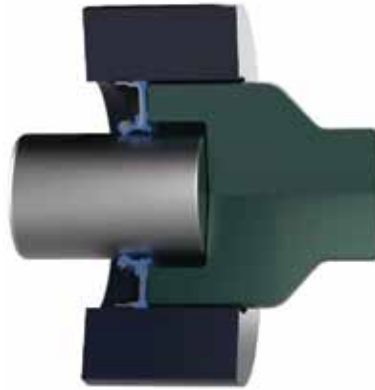

UNACCEPTABLE INSTALLATION METHODS

INSTALLATION

The following are schematics of common improper installation procedures. These methods are presented because they are commonly seen and not recognized as being incorrect in the industry. If a seal is improperly installed, it could be deformed or severely damaged, greatly reducing its life. Typically, when a seal is not properly installed, it will be cocked in the bore and fail in application.

IMPROPER DRIVING

Always use an appropriate type of driving ring to install the seal. Without it, localized seal deformation may occur.



UNDERSIZED INSTALLATION TOOL

If the driving diameter of the installation tool is too small, it may cause the seal to deform during installation.



INSTALLATION

POORLY ENGINEERED INSTALLATION TOOL

When the installation tool is not appropriate for the seal, deformation may occur. In this situation the installation tool should be designed similar to the Surface Stop Installation Tool.

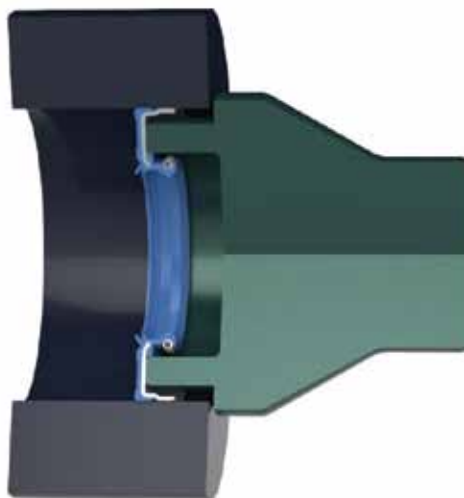

MISALIGNMENT ERRORS

When the center line of the tool and bore do not coincide, the seal may be deformed or cocked in the bore, providing a leak path for the media being sealed.

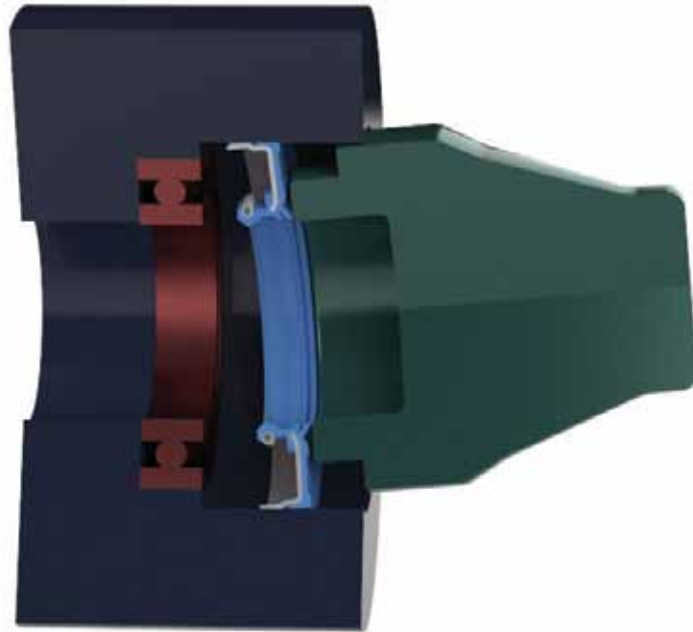

INSTALLATION

INSTALLATION CHECKLIST

- Bore: Verify the proper chamfer and remove any contamination, burrs or nicks.
- Shaft: Verify the proper lead in chamfer on end of shaft. Remove any burrs nicks, grooves or lead that could come in contact with the seal.
- Spline and keyways: Sharp edges should be covered with a lubricated assembly sleeve, shim stock or tape to protect the seal lip.
- Component Specifications: Check all components that come in contract with the seal and verify proper dimensions within tolerances, surface roughness and hardness.
- Part Interference: Verify that other machine parts do not rub against the seal, causing friction and damaging heat.
- Radial Shaft Seal: Visually inspect seal for cuts, nicks or other damage or contaminations. Verify that the spring is in place.
- Seal Direction: If replacing an existing seal, face in the same direction. Otherwise, generally, the lip faces the media being sealed.
- Pre-Lubrication: It is common practice to use lubrication to aid in installation for both the ID and OD of the seal. This is also beneficial for initial startup for the primary lip in application.
- Correct Installation Tool: Press-fitting tools should have an outside diameter approximately 0.010" (0.25mm) smaller than the bore size. For best results, the center of the tool should be open so pressure is applied only at the seal outer edge.
- Improper Driving Tool: Use proper driving tool such as a soft-face tool arbor press or soft work piece (wood). To avoid cocking the seal, apply force evenly around the outer edge.
- Avoid Cocking: Bottom out the tool on the shaft, the housing or bottom out the seal in the housing counter bore.

INSTALLATION

APPLICATIONS

TRACTOR PTO

PTO applications have one primary challenge, the ingress of fiber debris, either from weeds, straw, or sometimes baler twine. Fiber debris tends to wrap on the PTO shaft and collect next to the seal. That material can get forced into the seals dust lip and then into the main lip causing an aggressive leak.

The T26 design shown here is used to help guard against any ingress of fiber material. The design incorporates a metal guard, sometimes called a weed cutter. This guard has a slight clearance to the shaft and helps to cut up any straw or weeds before it has a chance to present itself at the dust lip.

Tractor PTO.

Seals are designed to help prevent plant fibers that tend to wrap on the PTO shaft from damaging the main lip.



T26



HIGH CONTAMINATION SEALING DESIGNS

The EVO and TSL series of seals are specifically designed for high contamination applications. Seals contain multiple lips and a labyrinth type pathway that slows the progression of mud and dirt into the seal.

The TSL is a unitized type design, incorporating multiple components that are crimped together forming one single piece for installation. The TSL series come pregreased, and incorporate a seal sleeve that eliminates any wear on the shaft surface. The TSL series are very effective at protecting your application from mud and debris.

The EVO series incorporates our patent pending EVO technology, a metal on metal sealing element that keeps large and small contamination from entering into the seal. The EVO technology can be used on it's own or incorporated with multiple exclusion lips for improved performance.



TSL11



TSL9



EVO
(patent pending)



APPLICATIONS

High Contamination Sealing Designs.

The EVO and TSL series seals are specially designed for high contamination applications.

TRACTOR AXLE - STANDARD FIELD ENVIRONMENT

Tractor axles are known for living in a dirty environment. Dirt and mud can get kicked up by the tires and at times fording through mud is required. This application requires a seal with higher than normal dirt exclusion capabilities.

With this application there are many choices available. Here we are showing a couple of common seals concepts, they can be modified to fit specific applications.

The T26 style shown incorporates a main seal lip for retention of oil in the axle, three dust lips for good dirt and dust exclusion and a metal can excluder that helps to keep large debris and weeds from entering the main lip.

The OUB2 style shown utilizes four long lips that run on a stamped metal insert. This style has a good life in dust/dirt environments when a greasing interval is specified in the application. The lips are designed such that grease will purge past the lips and effectively replace old dirty grease with fresh clean grease.

APPLICATIONS



T26



OUB2

Tractor Axle.

This applications requires a seal with higher than normal dirt exclusion capabilities.

HIGH SHAFT RUNOUT

Generally, radial shaft seals are installed in a location near a bearing, where the shaft is well supported and the runout or misalignment of the shaft to the bore is minimal. But at times seals are needed in locations where shaft runout can be excessive.

Our high runout line of seals can extend the runout capability of a standard seal and help to fix some runout issues that come up. The seal cross section incorporates a flexible membrane that helps the main lip follow a shaft with a high runout issue.

High Shaft Runout.

Sometimes seals are needed in locations where shaft runout can be excessive.



TBCC

APPLICATIONS



FLUID SPLITTING

Fluid splitting seals utilize a double sealing lip and are used in applications that involve the separation of two fluids.

These types of seals can be found in grease/oil applications. Or most commonly in wet clutch applications where a seal is needed between the engine and transmission/clutch.

Fluid Splitting Seals.

These types of seals can be found in grease/oil applications.

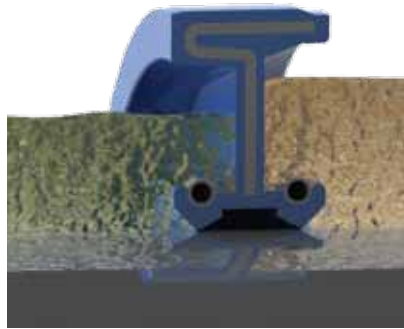

APPLICATIONS



DUO CONE FACE SEALS

Metal face seals are used in high contamination environments at moderate speeds. The seal consists in two metal rings that spin, one against the other, keeping out contamination in extreme conditions.

Metal faces are loaded with rubber o-rings which help to apply an even load to the face of the seal for the life of the seal, when the o-rings fail they can be replaced and the metal faces can be used again.



Duo Cone Face Seals.

Metal face seals are used in high contamination environments at moderate speeds.



APPLICATIONS



FL SEAL SERIES

The patent pending FL Series Seal™ offers a unique exclusion design that accommodates for production and application seal gap variability.

The FL Series Seal™ installs onto a chamfer with a specifically engineered angle and length. As the seal gap changes during use, the FL seal slides up and down the chamfer, maintaining constant contact with the sealing face.

Typical pivot pin applications utilize a standard pin or wiper seal to keep dirt out of the bearing or bushing. These standard pin seals will seal on the outer diameter of the pin, but as the seal lip wears, leakage can occur. The FL seal self-adjusts as the lip wears, extending the life of the seal itself.

FL Series Seals.

The patent pending FL design uses a seal cross section that rides on a chamfer.

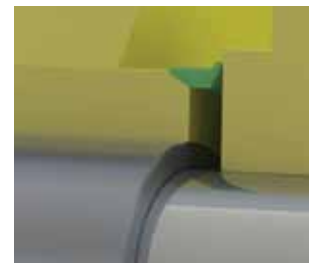
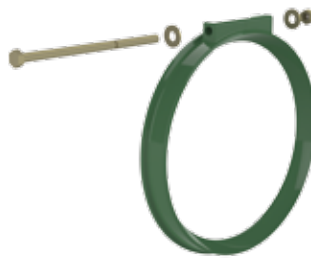

FL Seal Cross Section

APPLICATIONS

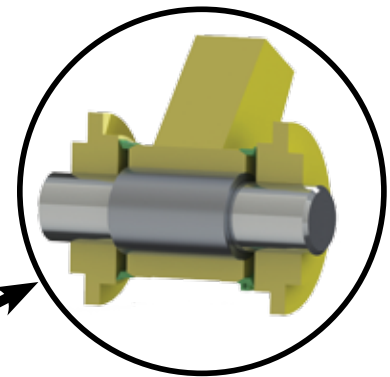



Request for Quotation

ESP International
 5920 Dry Creek Lane NE
 Cedar Rapids, IA 52402
 Ph: 319-393-4310
 Fax: 319-393-5327
 www.espint.com

Company:	Date:
Contact Name:	E-Mail:
Phone:	Fax:

Dim	Description	Value
SD	Shaft Diameter	
BD	Bore Diameter	
L	Bore Depth	
SA	Shaft Chamfer Angle	
SCL	Shaft Chamfer Length	
BA	Bore Chamfer Angle	
BCL	Bore Chamfer Length	
W	Seal Width	

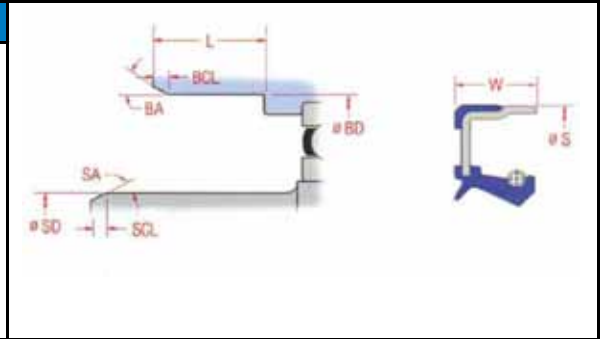

Shaft

Horizontal Vertical

Material:

Hardness:

Surface Finish:

Lead Angle:

Dynamic Runout:

Shaft Offset:

Bore

Straight Counterbore

Material:

Hardness:

Surface Finish:

Chamfer: Yes No

Shaft Motion

Rotating Normal Max

RPM:

Shaft Speed (ft / min) **

1 2 3 4 5

(0-500) (500-750) (750-1750) (1750-4000) (4000-up)

Reciprocating Oscillating

Stroke Length: Degrees of Arc

Cycle / Min: Normal Max

Contamination Level **

1 2 3 4 5

Particle Type:

% of Exposure:

% Submerged:

Temperature **

F C

Sump: Underlip: Outside:

Pressure (PSI) **

Standard Med/Low Med High

(0-10) (10-50) (500-1000) (< 1000)

Fluid / Lubrication

Grease Oil

Assembly

Removal: Rare Often

Space Restrictions: Yes No

Pilot Gap: ** Yes No

Shaft Installation Direction

Installation Direction into Bore

Type:

VI Index:

Sump Fill Level:

Application Description:

Usage **

Continuous Intermittent

Cycle Time: 1 2 3 4 5

Down Time: 1 2 3 4 5

CUSTOM SHAFT SEAL TESTING

ESP International specializes in sealing applications with a focus on radial shaft seal technology and testing. We offer customize radial shaft seal testing.

ESP Engineering's advanced shaft seal test facility utilizes shaft seal test machines that perform tests like Hot Oil tests, Dust and Slurry tests, Torque Testing, Pump Rate Testing, Lip Opening Force and Shaft Lead.



CUSTOM SEAL TESTING

Oil Testing Machine.

Seal testing machines allow different tests.

HOT OIL

ESP's test machines can simulate a shaft seal application by running a duty cycle similar to the actual application. Modification of the sealing parameters are possible during the running of test.

It is common to run varying shaft speeds over a set period of time. The table below shows a list of the parameters that can be modified:

PARAMETERS THAT CAN BE CHANGED	
Shaft speed	0-10,000 RPM
Fluid temperature	Ambient - 200°C
Fluid type	Customer specifications
Shaft run-out	0 - 0.5 mm
Shaft to bore misalignment	0 - 5 mm
Oil fill level	Half shaft, full shaft
Oil pressure	0 - 200 bar

CUSTOM SEAL TESTING

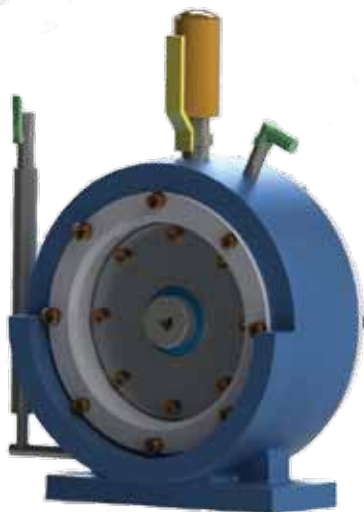

Hot Oil Testing Machine.

ESP's test machines can simulate a shaft seal application.

TORQUE TESTING

All shaft seals create some friction on the rotating shaft. That friction results in some power loss to the vehicle and in situations where maintaining vehicle power is important the selection of shaft seal becomes important as well.

Our seal power consumption test equipment can determine the amount of power drawn from various seal designs, giving you the proper information you need when selecting a shaft seal design.

PARAMETERS THAT CAN BE CHANGED

Shaft speed	200-10,000 RPM
Fluid temperature	Ambient
Fluid type	Customer specifications
Shaft run-out	0-0.5 mm
Shaft to bore misalignment	0-5 mm
Oil fill level	Half shaft, full shaft

CUSTOM SEAL TESTING

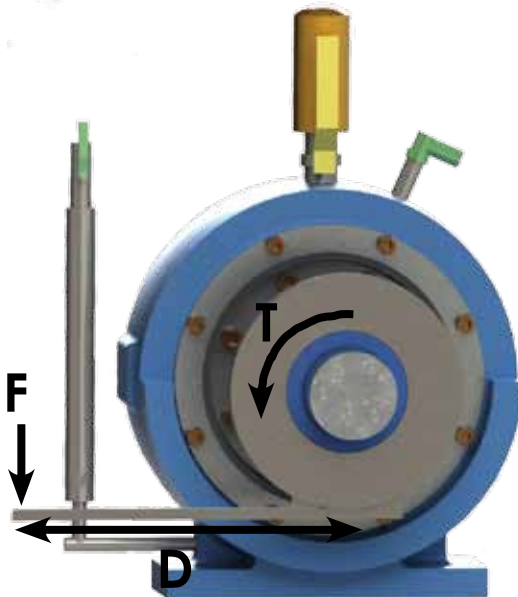

Torque Testing.

Our seal power consumption test equipment can determine the amount of power drawn from various seal designs.

DUST AND SLURRY SOLUTION

This is a bolt on option to our hot oil test machines. It allows you to introduce media to the excluding features of the seal. Mixtures of ISO 12103-1 test dust with bentonite clay and water are standard but it is possible to run any media such as belt dust, volcanic ash or water.

The sump and dust chamber are monitored daily for ingress of debris and failure of the seal. Comparison of seal designs is common with this type of test.

PARAMETERS THAT CAN BE CHANGED

Shaft speed	0-10,000 RPM
Fluid temperature	Ambient - 200°C
Fluid type	Customer specifications
Shaft run-out	0 - 0.5 mm
Shaft to bore misalignment	0 - 5 mm
Oil fill level	Half shaft, full shaft
Oil pressure	0 - 200 bar
Media on chamfer	Slurry, dust, water or other substance

CUSTOM SEAL TESTING

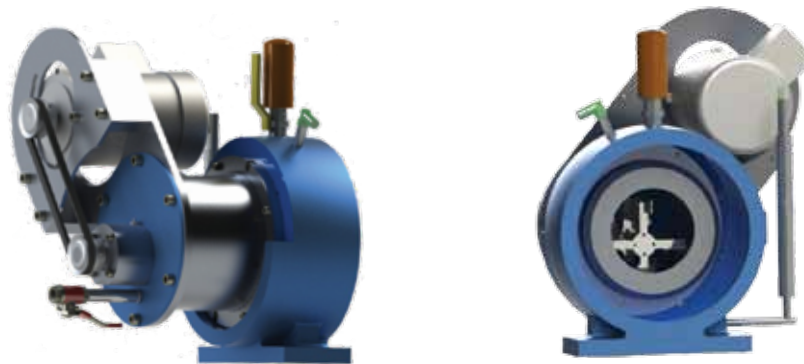

Slurry Chamber Assembly.

This is a bolt on option to our hot oil test machine.

PUMP RATE TESTING

Shaft seals work by the generation of a fluid pumping action under the seal lip.

The amount of oil pumped through the seal can be measured by placing another chamber on the front of the seal and introducing oil into that chamber. This effectively places oil on the air side of the seal and allows measurement of the amount of oil that transfers from the air side to the oil side, giving you the pump rate of the seal lip.

PARAMETERS THAT CAN BE CHANGED

Shaft speed	200-10,000 RPM
Fluid temperature	Ambient - 200°C
Fluid type	Customer specifications
Shaft run-out	0-0.5 mm
Shaft to bore misalignment	0-5 mm
Oil fill level	Half shaft, full shaft

CUSTOM SEAL TESTING

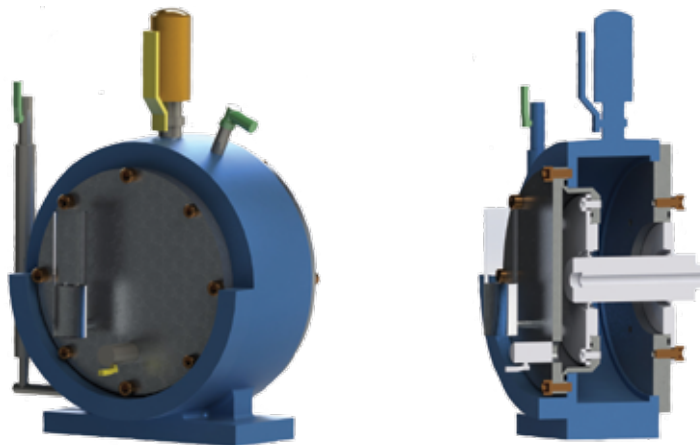

Pump Rate Testing.

Our pump rate testing equipment can determine the amount of oil that is pumped through the seal.

SHAFT LEAD TESTING

The surface of a shaft is normally formed from a machining process called lathe turning. This is where a cutting tool is along the surface of a spinning work piece or shaft and material is removed until the desired size is achieved. The one issue with lathe turned surfaces in radial shaft seals is the process creates a spiral groove on the shaft surface, or machining lead. That spiral groove acts to pump oil underneath the seal lip. Depending on the direction of lead and direction of rotation machining lead can improve sealability of a radial shaft seal or cause it to leak very quickly.

Because of the latter it is important to limit the amount of machining lead present in a shaft surface. If you ever have a seal with a leak it's important to understand the presence of this condition on the suspect shaft. ESP's radial shaft seal lab can provide support by inspecting shafts for machining lead problems and help identify a possible root cause for a seal leak issue.

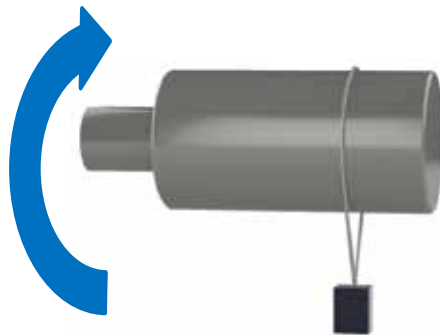

CW Rotation and weight stays stationary

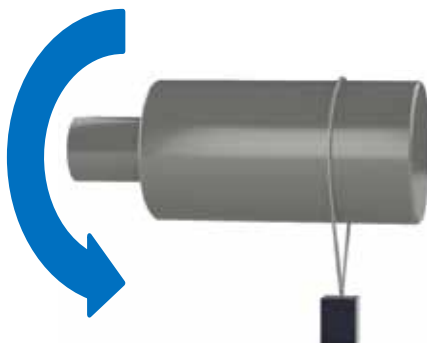

CCW Rotation and weight stays stationary

CUSTOM SEAL TESTING

Shaft Lead Testing.

The shaft surface may have spiral grooves that create lead on the shaft, potentially causing the seal to leak.

LIP OPENING FORCE TEST

Radial shaft seal use a spring to keep the lip pressed onto the shaft. After the seal has run for some time and the lip material has swelled and softened, the spring increases the ability of the lip to follow the shaft's dynamics.

The radial sealing force, also call load, that the lip exerts in the shaft affects the life of the seal. If the load is too high, it will wear out the lip faster causing it to fail. And if the load is not strong enough it will not generated enough force on the lip to seal when it swells. This load can be measure with ESP's LOF Machine.

PARAMETERS THAT CAN BE CHANGED

ID

10 - 150 mm

CUSTOM SEAL TESTING



Lip Opening Force.

Our LOF tester can determine the load that the lip exerts on the shaft.

CUSTOM TEST

ESP specializes in custom seals, which sometimes calls for custom testing machines. This is an example of one machine designed and built at ESP International to test the FL series.

Flod Seal Testing.

ESP International designed and built the testing machine to test a custom made seal.

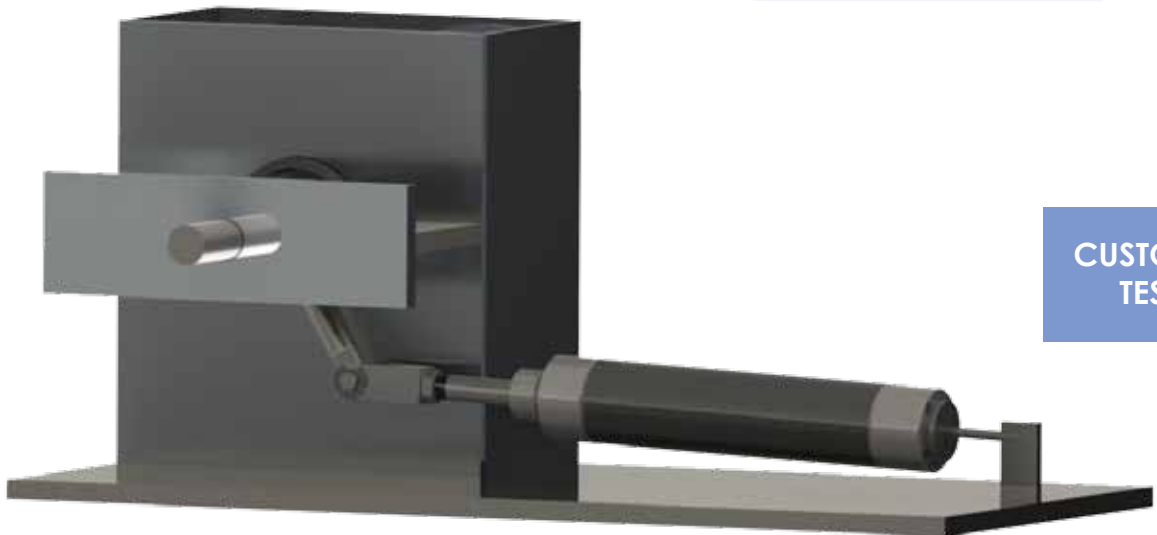

**CUSTOM SEAL
TESTING**

SEALING SYSTEM LEAKAGE

SEALING SYSTEM LEAKAGE ANALYSIS GUIDE

SECTION 1: Introduction

The Oil Seal Manufacturing Industry is committed to provide functional, efficient radial lip seals for all applications. If a sealing system leaks, it is most important that the manufacturer be provided with as much data about the sealing system and its environment as possible in order to provide a timely and correct solution.

The mere return of a leaking seal is not sufficient information on which to base corrective action. The following is a Leakage Analysis Guide prepared by the Technical Committee of the Oil Seal Subdivision of the Rubber Manufacturers Association.

SECTION 2: Sealing System

There are four elements to any sealing system:

- 2.1 The sealing device
- 2.2 The shaft or running surface
- 2.3 The housing bore
- 2.4 The medium to be sealed

It is not possible to provide an accurate analysis of a leaking sealing system without examination of all four elements.

SECTION 3: Purpose

The purpose of this document is:

- 3.1 To provide the seal user with a systematic method of documenting all factors related to a sealing system and its immediate environment.
- 3.2 To provide a comprehensive list of probable causes for the factors of conditions found.

**TROUBLE
SHOOTING**

3.3 To provide possible corrective actions for conditions found. This may enable the user to solve the problem without consulting the seal manufacturer.

3.4 To provide the seal manufacturer with comprehensive documentation of a sealing system deficiency.

SECTION 4: Use of this document

This document contains a three-part checklist designed to lead an investigator through a sequential sealing system leakage analysis.

Part 1 Examination of the sealing system and immediate environment with the seal in place.

Part 2 Examination of the seal after removal

Part 3 Examination of the other three elements (i.e., housing, shaft and lubricant) of the sealing system.

Completion of this three-part checklist should provide the examiner and eventually the seal manufacturer with sufficient information to diagnose the problem.

For each abnormal condition of the checklist, there is a reference code. Each reference code represents a page in the Causes and Countermeasures section of this guide. If a condition is checked on the list, the guide will provide a number of possible causes for that condition, as well as a number of possible countermeasures or corrective actions that could be taken by the responsible agency.

If the problem is not correctable by the user, the checklist should be forwarded, with the seal in question, to the seal manufacturer.

If it is not possible to provide all of the information requested on the checklist, it would be of benefit to the seal manufacturer to have access to all elements of the sealing system so that all relevant information can be gathered.

**TROUBLE
SHOOTING**

SEALING SYSTEM LEAKAGE ANALYSIS CHECKLIST

PART 1

An examination of the sealing system and immediate environment with the seal in place.		
Seal Application: Miles/Hours of Operation:		Equipment Identification: Complaint:
Before removal, carefully inspect the seal, the shaft and the immediate area around the leakage site. Follow this check-list:		
Amount of Leakage		
Slight <input type="checkbox"/>	Immediate area damp <input type="checkbox"/>	Heavy leakage <input type="checkbox"/>
Source of Leakage		
Check <input type="checkbox"/> <input type="checkbox"/> <input type="checkbox"/> <input type="checkbox"/> <input type="checkbox"/> <input type="checkbox"/>	Location Between shaft and seal lip Between OD of seal and bore At retainer bolt holes At retainer gasket Between wear sleeve and shaft Through seal on assembled seal	Reference Code ----- B.2.5 B.3.1 B.3.2 B.3.7 B.3.8
Condition of Immediate Environment		
Seal area clean <input type="checkbox"/>	Mud or dust packed in seal area <input type="checkbox"/>	B.2.1
Wipe Immediate Area Clean and Inspect		
Check <input type="checkbox"/> <input type="checkbox"/> <input type="checkbox"/> <input type="checkbox"/> <input type="checkbox"/> <input type="checkbox"/> <input type="checkbox"/>	Condition Nicks on bore chamfer Seal loose in bore Paint spray on seal lip Seal cocked in bore (amount) _____ Seal installed in wrong orientation (backwards) Seal case deformed Shaft to bore misalignment	Reference Code B.1.1 B.1.2 B.2.2 B.2.3 B.2.4 B.2.6 B.3.5
Rotate Shaft if Possible Check for Radial & Axial Play		
<input type="checkbox"/>	Excessive shaft end play (amount) _____	B.3.3
<input type="checkbox"/>	Excessive shaft runout (amount) _____	B.3.4
Note: If location of leakage cannot be confirmed at this point, either introduce ultra-violet dye into the sump or spray area with white powder, operate for 15 minutes and check for leakage with ultraviolet or regular light. When above analysis is complete, mark the seal at the 12 o'clock position and carefully remove from the application.		
<input type="checkbox"/>	Oil sample obtained	B.3.6
Completed by: _____		Date: _____

TROUBLE SHOOTING

SEALING SYSTEM LEAKAGE ANALYSIS CHECKLIST

PART 2

Clean the removed seal in a mild solvent. Do not attempt to scrape away carbon, etc. Inspect the seal using this checklist.

Primary Lip Area		
Check	Condition	Reference Code
<input type="checkbox"/>	Normal wear	C.2.1.1
<input type="checkbox"/>	No wear	C.2.1.1
<input type="checkbox"/>	Excessive wear	C.2.1.1
<input type="checkbox"/>	Eccentric wear	C.2.1.3
<input type="checkbox"/>	Inverted lip due to poor installation	C.2.1.10
<input type="checkbox"/>	Nicks, scratches or cuts at lip contact area	C.2.1.4
<input type="checkbox"/>	Hardened or cracked rubber	C.2.1.6
<input type="checkbox"/>	Coked oil on lip	C.2.1.8
<input type="checkbox"/>	Softening or swelling	C.2.1.9
Seal Outside Diameter		
Check	Condition	Reference Code
<input type="checkbox"/>	Normal	-----
<input type="checkbox"/>	Severe axial scratches	C.2.2.2
<input type="checkbox"/>	Peeled rubber	C.2.2.3
<input type="checkbox"/>	Hardened rubber	C.2.2.4
<input type="checkbox"/>	Nonfills or cuts	C.2.2.5
Spring and Spring Groove Area		
Check	Condition	Reference Code
<input type="checkbox"/>	Spring normal and in place	-----
<input type="checkbox"/>	Spring missing	C.2.3.1
<input type="checkbox"/>	Spring corroded	C.2.3.2
<input type="checkbox"/>	More than one spring	C.2.3.4
<input type="checkbox"/>	Separated spring	C.2.3.5
Make the Following Measurements		
Primary lip inside diameter?	(_____)	C.2.1.7
Primary lip radial force?	(_____)	C.2.1.7
Seal outside diameter?	(_____)	C.2.2.1
Spring inside diameter?	(_____)	C.2.3.3
Spring tension?	(_____)	C.2.3.3
Primary lip wear band width?		
Min.	(_____)	
Max.	(_____)	
Comments:		
Completed By: _____		Date: _____

TROUBLE SHOOTING

SEALING SYSTEM LEAKAGE ANALYSIS CHECKLIST

PART 3

An examination of the housing, shaft and lubricant (after seal removal).		
Inspect the Housing Bore Area		
Check	Condition	Reference Code
<input type="checkbox"/>	Measure bore diameter: (_____)	C.1.1
<input type="checkbox"/>	Bore chamfer damaged	C.1.2
<input type="checkbox"/>	Flaws or voids in housing	C.1.3
<input type="checkbox"/>	Tool withdrawal marks in bore	C.1.4
<input type="checkbox"/>	Bore surface scratched or galled	C.1.5
Inspect the Shaft in the Seal Contact Area		
Check	Condition	Reference Code
<input type="checkbox"/>	Measure shaft diameter: (_____)	C.3.1
<input type="checkbox"/>	Shaft surface corroded	C.3.3
<input type="checkbox"/>	Seal wear path in wrong location	C.3.4
<input type="checkbox"/>	Scratches or nicks at lip contact area	C.3.5
<input type="checkbox"/>	Measure wear path width: (_____)	C.3.7
<input type="checkbox"/>	Discoloration on shaft surface	C.3.8
<input type="checkbox"/>	Coked lubricant present	C.3.8
<input type="checkbox"/>	Shaft chamfer damaged or missing	C.3.11
<input type="checkbox"/>	Wear sleeve loose on shaft (if applicable)	C.3.13
Remove Shaft from Application for Further Inspection		
	Characteristic	Reference Code
<input type="checkbox"/>	Measure surface roughness: (_____Ra)	C.3.2
<input type="checkbox"/>	Measure depth of wear path: (_____)	C.3.6
<input type="checkbox"/>	Measure shaft lead: (_____Deg)	C.3.9
<input type="checkbox"/>	Measure shaft hardness: (_____Rc)	C.3.10
<input type="checkbox"/>	Check for proper shaft material	C.3.12
Inspect the Lubricant		
Check		Reference Code
<input type="checkbox"/>	Contaminates (particulates) in filtered lube	C.4.1
Compare Lubricant from Application with New Lubricant for Proper Type		
Check	Condition	Reference Code
<input type="checkbox"/>	Color different	C.4.2
<input type="checkbox"/>	Viscosity different	C.4.2
<input type="checkbox"/>	Odor different	C.4.2
Completed By: _____		Date: _____

TROUBLE SHOOTING

SEALING SYSTEM LEAKAGE ANALYSIS CHECKLIST

SHORT FORM

Intended for field or shop work where the more comprehensive 3-part checklist may not be practical.			
Seal Application:		Equipment Identification:	
Miles/Hours of Operation:		Complaint	
Step 1: Inspect the Seal Application Before Removal			
Amount of leakage Condition of area Leakage source	<input type="checkbox"/> Slight <input type="checkbox"/> Clean <input type="checkbox"/> Between lip and shaft <input type="checkbox"/> At retainer gasket <input type="checkbox"/> At retainer bolt holes	<input type="checkbox"/> Seal area damp <input type="checkbox"/> Dusty <input type="checkbox"/> Between OD and bore <input type="checkbox"/> Between elements of seal <input type="checkbox"/> Between wear sleeve and shaft	<input type="checkbox"/> Heavy leakage <input type="checkbox"/> Mud packed
Step 2: Wipe Area Clean and Inspect			
Check Conditions Found	<input type="checkbox"/> Nicks on bore chamfer <input type="checkbox"/> Seal cocked in bore <input type="checkbox"/> Seal installed wrong <input type="checkbox"/> Shaft to bore misalignment	<input type="checkbox"/> Seal loose in bore <input type="checkbox"/> Seal case deformed <input type="checkbox"/> Paint spray on seal <input type="checkbox"/> Other	
Step 3: Rotate Shaft if Possible			
Check Conditions	<input type="checkbox"/> Excessive end play	<input type="checkbox"/> Excessive runout	
Step 4: If the location of the leak cannot be confirmed at this point, either introduce ultra violet dye into the sump or spray area with white powder, operate for 15 minutes and check for leakage with ultraviolet or regular light.			
Step 5: Mark the Seal at the 12 O'Clock Position and Remove it Carefully			
	<input type="checkbox"/> Retain an oil sample		
Step 6: Inspect the Application with Seal Removed			
Check Conditions Found	<input type="checkbox"/> Rough bore surface <input type="checkbox"/> Shaft clean <input type="checkbox"/> Coked lube on shaft <input type="checkbox"/> Shaft damaged	<input type="checkbox"/> Flaws or voids in bore <input type="checkbox"/> Shaft corroded <input type="checkbox"/> Shaft discolored	
Step 7: Inspect the Seal			
Primary Lip Wear	<input type="checkbox"/> Normal <input type="checkbox"/> None	<input type="checkbox"/> Excessive <input type="checkbox"/> Damaged	<input type="checkbox"/> Eccentric <input type="checkbox"/> Hardened (stiff)
Primary Lip Condition	<input type="checkbox"/> Normal <input type="checkbox"/> Soft (flexible)	<input type="checkbox"/> Axial scratches	<input type="checkbox"/> Damaged rubber
Seal OD	<input type="checkbox"/> Normal	<input type="checkbox"/> Missing	<input type="checkbox"/> Separated
Spring	<input type="checkbox"/> In Place <input type="checkbox"/> Corroded		
Comments:			
Completed By: _____		Date: _____	

TROUBLE SHOOTING

SEALING SYSTEM LEAKAGE

B.1.1 Nicks on Bore Chamfer

Probable Causes	Action or Countermeasures
1. Mishandling prior to seal installation (Fig. 1)	Check bore/housing machining
2. Insufficient material removal	Check casting dimensions for proper material allowance. Check machining locations for proper gage points.
3. Tool chatter on chamfer surface (Fig. 2)	Review machining procedures for proper tool configuration, feed, speed and coolant.



Fig. 1



Fig. 2

B.1.2 Check for Looseness in Bore

Probable Causes	Action or Countermeasures
1. Oversized bore ID.	Check bore machining dimensions for out of tolerance condition.
2. Undersize seal OD.	Check seal OD for out of tolerance.
3. Rolling of seal into bore during installation.	Review installation procedure and use proper installation tools.
4. Bore sizing.	Increase bore material hardness or use bore sealant.
5. Excessive shrinkage/hardening of rubber OD seal.	Review application temps, and seal material specifications.
6. Deformation of seal during installation (Fig 1).	Review installation procedure and use of proper tool.



Fig. 1

TROUBLE SHOOTING

B.2.1 Contaminants (Mud or Dust) Packed in Seal Area

Probable Causes	Action or Countermeasures
1. Failure of auxiliary lip. (Fig. 1)	Look for cut or damaged auxiliary lip. Look for auxiliary lip worn excessively.



Fig. 1

B.2.2 Paint Spray on Seal Lip

Probable Causes	Action or Countermeasures
1. Lack of paint mask	Review paint procedure, recommend a mask
2. Service or in field paint procedure	Issue a service bulletin to prevent paint overspray or specify a mask

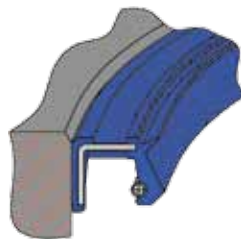

Paint spray particles

TROUBLE SHOOTING

B.2.3 Check for Seal Cocking

Probable Causes	Action or Countermeasures
1. Seal installation (Fig. 1)	Use proper installation tool. Check installation force to insure complete installation
2. Insufficient or improper bore chamfer	Provide proper amount and lead in angle for chamfer
3. Excessive seal interference with rubber OD seal	Check bore ID and seal OD for proper dimensions



Fig. 1

B.2.4 Check for Proper Installation and Orientation Relative to Assembly

Probable Causes	Action or Countermeasures
1. Backward installation caused by lack of proper installation tool or visual aide (Fig. 1)	Provide foolproof installation tool and/or visual aide to identify proper orientation
2. Improper axial location of seal (Fig. 2)	Provide proper installation tool
3. Improper axial position of shaft (Fig. 3)	Provide proper installation tool and visual aide for proper position



Fig. 1



Fig. 2

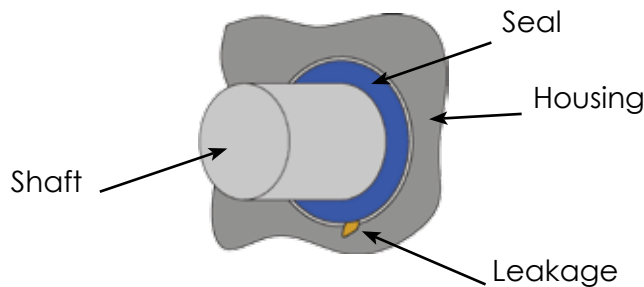

Fig. 3

TROUBLE SHOOTING

B.2.5 Check for OD Leakage

Probable Causes	Action or Countermeasures
1. Oversized bore/undersized seal	Check bore and seal diameters at removal
2. Damaged housing	Check upon removal
3. Damaged seal	Check for OD damage upon removal
4. Differential thermal expansion (aluminum or magnesium housing)	Calculate fit at maximum temperature



B.2.6 Check for Case Deformation (dishing or damage)

Probable Causes	Action or Countermeasures
1. Dented heel face caused by hammer installation	Provide proper installation tool
2. Dished heel face caused by improper tool	Provide proper installation tool

TROUBLE SHOOTING

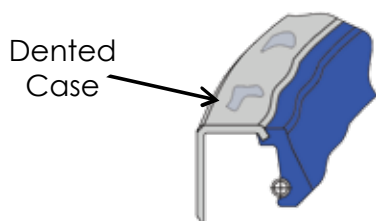

Fig. 1

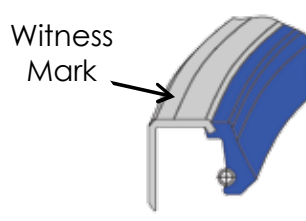

Fig. 2

B.3.1 Check Bolt Holes for Leakage

Probable Causes	Action or Countermeasures
1. Threads in housing tapped into fluid reservoir	Review product machining specifications
2. Insufficient bolt tightening	Provide proper installation tool
3. Undersize bolt diameter or oversize thread tap	Measure bolt and bolt hole for fit
4. Material thermal expansion incompatibility	Insure the bolt, housing material have similar thermal characteristics for temperature extremes
5. Vibration	Use locking method so bolt won't work loose
6. Bolt fracture	Check bolt loading specs and operating parameters
7. Contamination	Insure bolt hole is free of particles or corrosive fluids prior to bolt installation
8. Corrosion	Insure bolt housing and material are compatible with application environment
9. Bolt missing	Install specified bolt
10. Cross threading	Retap and use correct bolt
11. Improper bolt	Change to correct bolt size
12. Improper head type	Change to correct bolt

TROUBLE SHOOTING

B.3.2 Check Gaskets for Leakage

Probable Causes	Action or Countermeasures
1. Heat aging causes stress or cracking	Use high temperature gasket material compression set
2. Improper machining or mating surface	Review machining procedure for proper machining techniques
3. Casting porosity or other hardware surface	Inspect hardware surface for visual defects prior to gasket installation
4. Excess gasket preload resulting in compression	Review bolt torque requirements set
5. Gasket swell, soft, hard from chemical attack	Check fluid compatibility of gasket material
6. Torn gasket	Use proper installation procedures and tools
7. Crimped or folded gasket	Use proper installation procedures and tools
8. Gasket blown out	Review system pressure specs, field application conditions, check gasket hardness
9. Dry gasket	Replace gasket
10. Wrong size	Use correct gasket
11. No sealant on gasket	Apply sealant
12. No gasket	Install gasket

TROUBLE SHOOTING

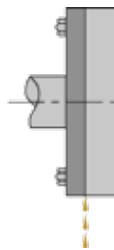

B.3.3 Check for Axial Shaft End Play

Probable Causes	Action or Countermeasures
1. Worn thrust bearing	Replace bearing
2. Shearing of lock ring or locking key	Check hardness of lock device and dynamic
3. Wear sleeve on shaft is loose	Check press or bond fit for sleeve
4. Negative stack-up in hardware tolerances	Review product prints

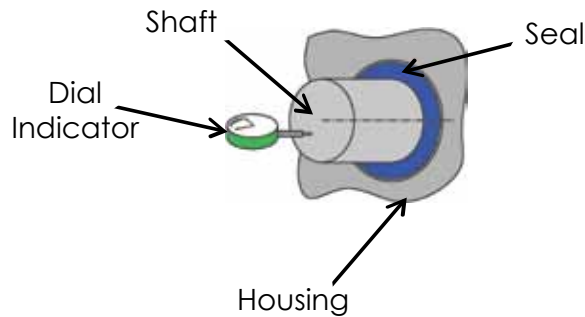

B.3.4 Check for Excessive Shaft Runout

Probable Causes	Action or Countermeasures
1. Failed bearing	Exceeded bearing load capacity. Excessive wear or contamination-replace bearing.
2. Excessive shaft deflection	Balance shaft and/or support shaft better
3. Shaft machined out of tolerance	Review shaft print specs and production limits and tolerances, and adjust process

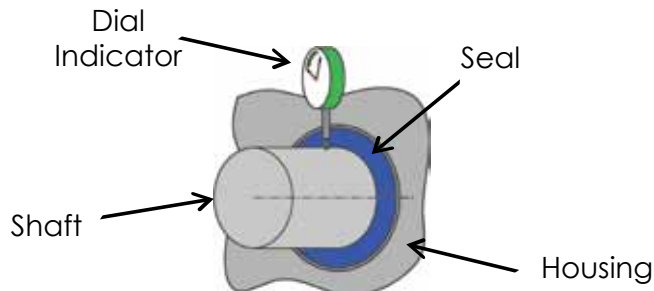

TROUBLE SHOOTING

B.3.5 Check for Shaft to Bore Misalignment

Probable Causes	Action or Countermeasures
1. Poor initial alignment (Fig. 1)	Review design and assembly operations and provide accurate alignment
2. Seal manufactured with high radial wall variation	Review production quality data, adjust process

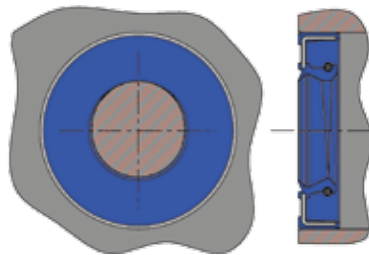

Fig. 1

B.3.6 Obtain Oil or Sealed Lubricant Sample

Probable Causes	Action or Countermeasures
1. Wrong fluid	Correct procedure for initial fill
2. Degraded fluid	Review fluid specification verses sump temperature and change the fluid requirement or sump temperatures
3. Degraded pre-lube	Specify pre-lube with temperature capabilities equal or better than fluid sealed
4. Contaminated fluid	Locate source of contamination and remove

TROUBLE SHOOTING

B.3.7 If a Wear Sleeve is Used, Check for Leakage Between Shaft and Sleeve

Probable Causes	Action or Countermeasures
1. Improper sleeve press fit	Inspect at removal
2. Damaged shaft	Inspect at removal
3. Improperly finished shaft (chatter)	Inspect at removal

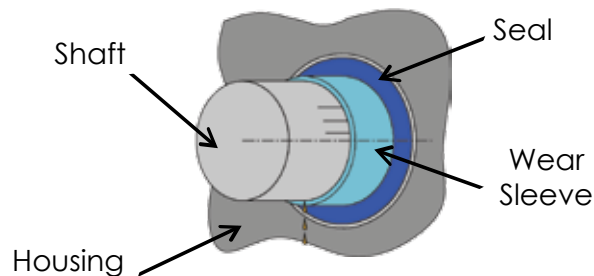

B.3.8 If Assembled Seal, Check for Leakage Between Clamped Elements

Probable Causes	Action or Countermeasures
1. Improper seal manufacturing (insufficient clamping force) (Fig. 1)	Consult seal manufacturer
2. Severe dish or bulge of seal assembly at time of installation (Fig 2)	Excessive interference between seal OD and bore

TROUBLE SHOOTING

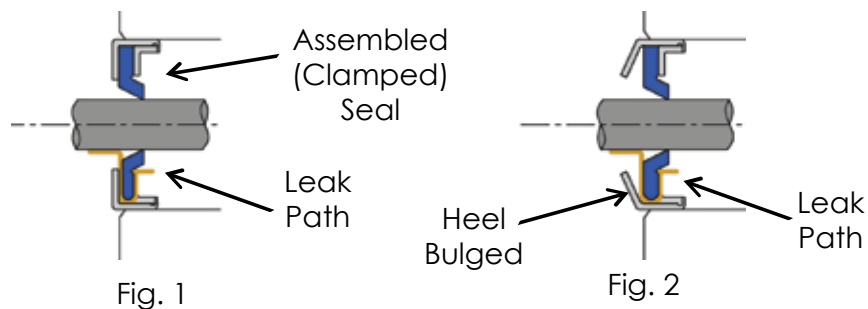

C.1.1 Measure Bore Diameter

Probable Causes	Action or Countermeasures
1. Seal loose	Use correct OD seal- machine bore to correct size
2. Oversize bore diameter resulting from seal press fit deformation	Check seal for proper OD size. Increase housing radial wall in area of seal gland
3. Tapered bore diameter resulting from improper machining techniques	Specify maximum axial diameter taper
4. Undersize or oversize bore due to design error	Contact OEM for corrective action
5. Oversize bore not in dimensional agreement with OEM specification	Unit may be a rebuild. Check seal OD diameter and order proper replacement part
6. Seal collapsed	Replace damaged seal with correct size

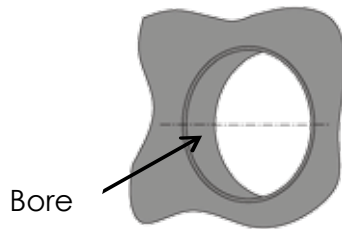

TROUBLE SHOOTING

C.1.2 Check Bore Chamfer

Probable Causes	Action or Countermeasures
1. Chamfer lead-in not adequate to install seal due to improper chamfer angle	Review machining practices and product drawing
2. Deformation of lead-in chamfer edge due to chamfer diameter less than maximum OD of seal	Check OD of seal to insure not oversize, check ID of chamfer to insure it meets specs
3. Chamfer not present due to machining or product drawing error	Review product drawing and make the appropriate changes
4. Chamfer deformed due to seal installation	Increase bore hardness, use rubber OD seal
5. Chamfer too long causing insufficient flat area for seal retention	Check drawing and chamfer angle. Measure seal width to insure proper part and fit.

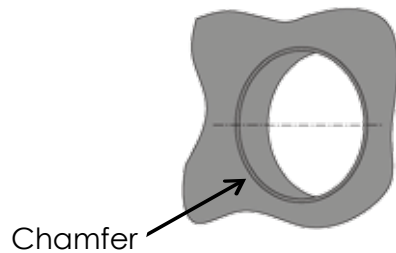

TROUBLE SHOOTING

C.1.3 Inspect for Flaws or Voids in Housing

Probable Causes	Action or Countermeasures
1. Porosity in housing resulting from casting defect	Review foundry practices
2. Circumferential scratches, burrs, and gouges due to machining	Review machining techniques and specification
3. Cracks in housing due to heat treating or mishandling	Review material heat treating specification and handling practice
4. Grinding media embedment producing rough surface	Review machining practices

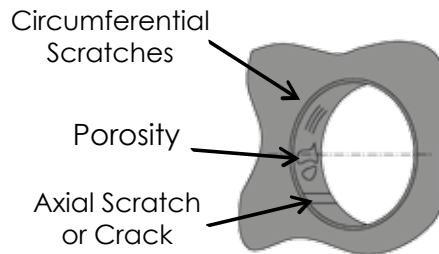

C.1.4 Check for Tool Withdrawal Marks on Bore

Probable Causes	Action or Countermeasures
1. Poor machining practices. Tool in contact with surface during removal	Review machining techniques
2. Leakage thru machine marks	Apply OD sealant to seal and/or bore. Machine to larger OD and use larger seal. Machine bore and install sleeve.

TROUBLE SHOOTING

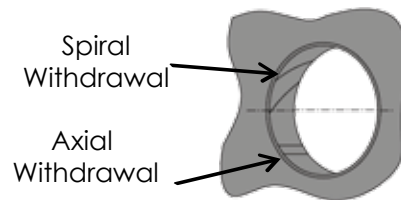

C.1.5 Check for Severe Scratches or Galling Marks on Bore

Probable Causes	Action or Countermeasures
1. Scratches and galling due to poor handling techniques	Review handling and shipping practices
2. Scratches and galling due to machining operations	Review machining practices
3. Scratches and galling due part assembly; i.e. shaft, seal and bearings	Review assembly practices
4. Leakage through imperfections.	Machine and use larger OD seal. Machine and install sleeve.

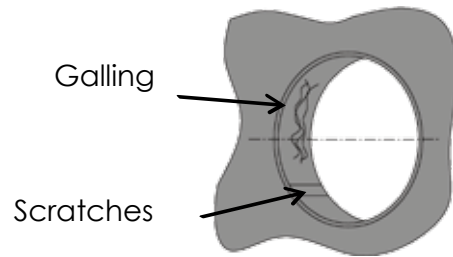

TROUBLE SHOOTING

C.2.1.1 Lack of Wear

Usually associated with insufficient radial force or over-abundance of lubrication

Probable Causes	Action or Countermeasures
1. No interference with shaft	Check seal ID for garter spring. Check shaft dia. Observe shaft for evidence of contract. Look for concave distortion on outside face of seal
2. Very light interference with shaft	Check seal ID for low radial load. Look for concave distortion on seal outside face
3. Seal installed backwards	Check installation method and teardown report
4. Heavy continuous leakage from startup, possible from another source	Check fluid consumption reports – look for excessive interference. Leakage may be occurring through a defect; check seal ID and shaft for defects
5. Dynamic lift-off centrifugal force, flutter or stick-slip action	Check for low radial load and spring presence. Check lip opening pressure on shaft size mandrel.
6. Reverse hydrodynamic pumping direction	Check shaft rotation direction with helix. Check for spiral lead or axial scratches on shaft.

TROUBLE SHOOTING

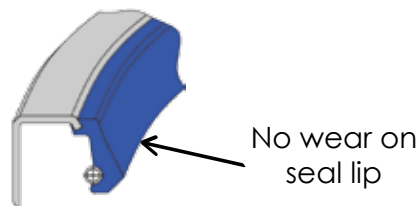

C.2.1.1 Excessive Wear

Probable Causes	Action or Countermeasures
1. Excessive interference	Check seal ID and shaft size (interference)
2. Excessive radial force	Check for high radial load. Look for small ID garter spring
3. Excessive pressure on lip	Check system pressure at operating conditions
4. Rough shaft finish	Inspect shaft for defects, measure surface finish
5. Insufficient lubrication at seal lip	Provide lube on seal airside or between lips



C.2.1.3 Eccentric Wear

Probable Causes	Action or Countermeasures
1. Seal cocked in assembly (Fig. 1)	Check shaft for wide wear path. Check installation procedure and equipment
2. Excessive radial wall variation of lip	Measure seal radial wall variation and relate to wear pattern
3. Excessive shaft to bore misalignment	Check shaft to bore offset (Fig. 2)
4. Angled or cocked shaft (Fig. 3)	Check shaft alignment, excessive runout or bent shaft
5. Side load applied to shaft	Check possible side deflection or loose bearings

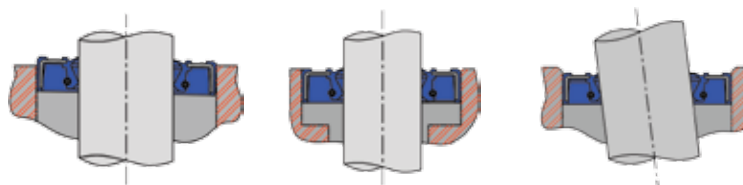

Fig 1
Cocked Seal

Fig 2
Excessive STBM

Fig 3
Cocked Shaft

C.2.1.4 Nicks, Scratches or Cuts at Lip Contact Area

Probable Causes	Action or Countermeasures
1. Sharp edge or burrs on end of shaft	Inspect shaft for burrs or sharpness
2. Sharp edge or burrs on installation tool	Inspect installation tool for burrs, sharp edge
3. Seal installed over keyway or splines	Use installation sleeve for splines, keyways
4. Trimming knife cuts	Check supplier's knife trimming methods
5. Nibbled appearance at sealing edge	Defects may be caused by bulk finishing or handling by supplier
6. Cuts from packaging method	Check supplier's packaging and shipping methods

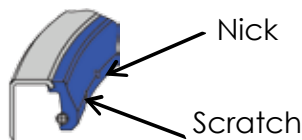

C.2.1.5 Tears or Separations in Lip Area

Probable Causes	Action or Countermeasures
1. Stress fatigue in flex section (Fig. 1)	Check system pressure. Seal may be deformed in ID flex section
2. Bond separation at ID of metal case (Fig. 2)	Check seal for bond, burrs, and blisters
3. Migration of low temperature crack	Check lip contact area for minor cold cracks. Suspect severe side load at low temperature
4. Circumferential tear behind lip (Fig. 3) possibly from another source	Look behind lip at base for circumferential tear caused by pressure or fatigue
5. Caused during disassembly or removal	Review teardown and seal removal methods and check tools used

TROUBLE SHOOTING

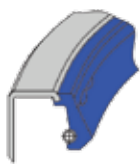

Fig. 1



Fig. 2



Fig. 3

C.2.1.6 Hardening or Cracking of Rubber

Probable Causes	Action or Countermeasures
1. Prolonged or excessive high temp exposure	Check rubber spec. vs. system temp profile
2. Flexing of lip at temps below rubber capability	Check rubber spec. vs. system temp profile. Check offset, runout and sideplay
3. Extended dry running causing localized high temperature under lip	Check fluid level, check that shaft isn't too smooth
4. Cracking from disassembly or observation techniques	Review procedures and look for other damages
5. Ozone exposure	Check other dry areas of rubber, consider excessive solar or electrical exposure

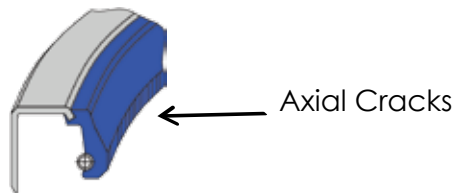

C.2.1.7 Measure ID and Radial Load

Probable Causes	Action or Countermeasures
1. Measure ID using non-contact device	Use optical comparator or linear scope. Record min/max readings and relate to leak
2. Measure wear pattern width and variation	Use optical means, photographic, or cross sections in comparator
3. Compare profile with profile of new seal	Section seal and mount on glass slide for magnified comparator viewing
4. Measure radial ID force	Use electronic split mandrel type radial load device (ref: RMA doc. OS-6)

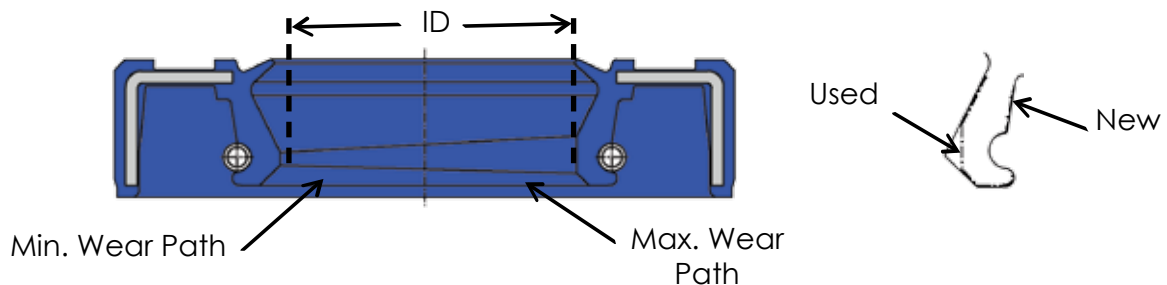

TROUBLE SHOOTING

C.2.1.8 Coked Oil on Lip

Probable Causes	Action or Countermeasures
1. Hard and glazed deposit on ID	Possibly decomposed fluid. Scrape and analyze
2. Insufficient hydrodynamic pumping action	Helices ineffective
3. Excessive under-lip temperature	Check fluid specs vs. operating parameters

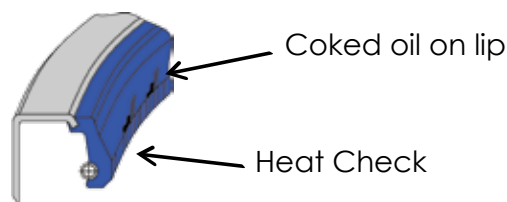

C.2.1.9 Softening or Swelling

Probable Causes	Action or Countermeasures
1. Volume change of material very high	Refer to elastomer physical data, check fluid
2. Reversion	Check elastomer/fluid compatibility specs
3. Exposure to solvent used during teardown	Review teardown procedure and elastomer compatibility with solvents
4. Operational contamination of fluid being sealed	Check for possible exposure to unspecified media coming in contact with seal

TROUBLE SHOOTING

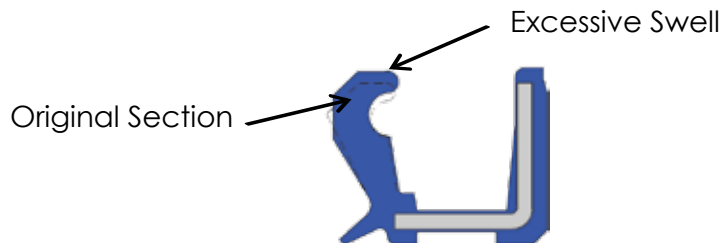

C.2.1.10 Inverted Lip Due to Poor Installation

Probable Causes	Action or Countermeasures
1. Oil to air side assembly	Provide installation aide such as bullet nose for shaft
2. Lack of proper concentricity assembly	Provide centering aide for assembly such as locating pins

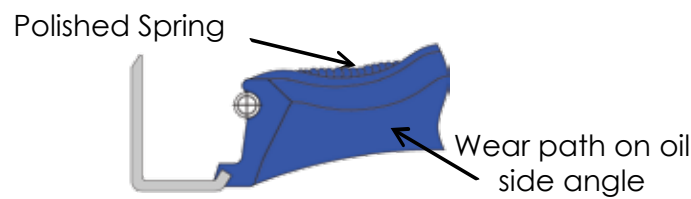

C.2.2.1 Measure Seal Outer Diameter

Probable Causes	Action or Countermeasures
1. Wrong seal for application	Check for proper seal identification
2. Bore or housing reworked	Check housing print. Also check for evidence of rework such as chuck marks

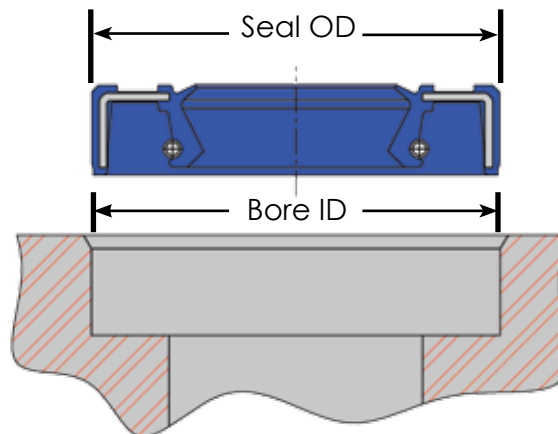

TROUBLE SHOOTING

C.2.2.2 Check for Severe Scratches on OD

Probable Causes	Action or Countermeasures
1. Damaged bore or bore chamfer (Fig. 2)	Check bore and chamfer condition
2. Die scratches from case operation	Check for OD coating or sealant in scratch (Fig. 1)

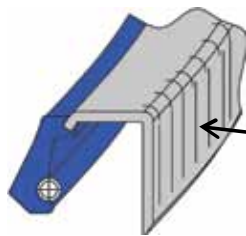

Fig. 1

Coating or Sealant in scratches

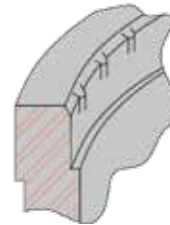

Fig. 2

C.2.2.3 Check for Peeled Rubber on OD

Probable Causes	Action or Countermeasures
1. Poor rubber bond to case (Fig.1)	Case OD clean at rubber interface
2. Lack of lubrication of OD at assembly	Case OD has rubber adhering to it
3. Lack of proper lead-in chamfer (Fig. 2)	Check bore chamfer condition

TROUBLE SHOOTING



Fig. 1

Chamfer too small or sharp

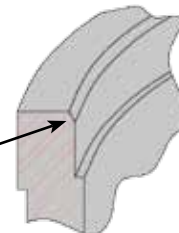
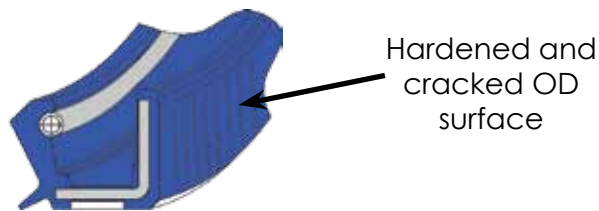

Fig. 2

C.2.2.4 Check for Hardened Rubber on OD (Rubber OD Design)

Probable Causes	Action or Countermeasures
1. Excessive heat in application	Check for other evidence of overheating
2. Improper seal material selection	Check material vs. operating temperature of lube compatibility



C.2.2.5 Rubber OD Nonfills/Cuts

Probable Causes	Action or Countermeasures
1. Improper seal manufacture. Prep weight or shape out of spec. (Fig. 1)	Consult seal manufacturer
2. Bore chamfer sharp or damaged. (Fig. 2)	Inspect bore chamfer

TROUBLE SHOOTING



Fig 1

Chamfer too small or sharp or burred

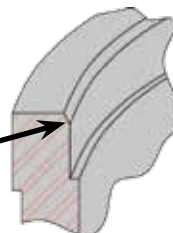
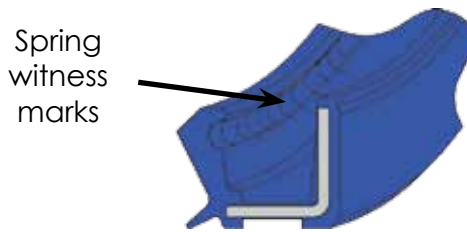

Fig 2

C.2.3.1 Missing Spring

Probable Causes	Action or Countermeasures
1. Seal may never have had a spring	Check for spring witness marks in spring groove. Also light wear on primary lip
2. Spring may have become dislodged during seal or shaft installation	Check installation procedures
3. Spring joint may have separated	Check installation procedures. Check garter spring joint quality (RMA OS-5)



C.2.3.2 Corroded Spring

Probable Causes	Action or Countermeasures
1. Spring may not have had proper rust.	Check new seals from same supplier
2. Application may be exposed to excessive moisture	Check for moisture in lube or corroded components
3. Application may contain a corrosive fluid	Specify stainless steel spring
4. Seal may have been improperly packaged and/or stored prior to installation	Check service stock
5. Wrong spring material	Consult supplier

TROUBLE SHOOTING

C.2.3.3 Check for Correct Dimensions and Spring Load

Probable Causes	Action or Countermeasures
1. Wrong spring on seal (excessive or no wear on primary lip groove)	Check seal drawing for spring dimensions. Also light wear on primary lip groove
2. Spring not properly normalized	Check seal drawing. Check for proper heat treatment (RMA OS-5)
3. Improperly manufactured spring	Check seal drawing for spring dimensions

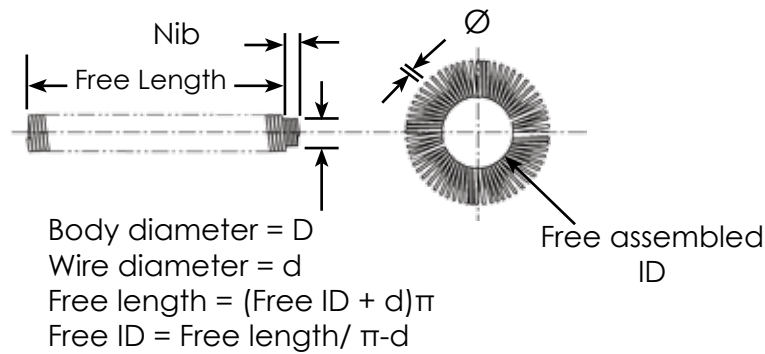

C.2.3.4 Multiple Springs

Probable Causes	Action or Countermeasures
1. Malfunctioning spring installation equipment at seal manufacturing location.	System audit at supplier.
2. Loose springs at seal installation station. Extra spring installed by assembler	Review installation station. Remove any loose springs. Review seal design and packaging.



TROUBLE SHOOTING

C.2.3.5 Separated Spring

Probable Causes	Action or Countermeasures
1. Improper spring nib configuration	Inspect spring per RMA OS-5
2. Excessive vibration or stick-slip of seal.	Inspect primary lip for excessive, cyclical seal wear
3. Improper seal installation. Review installation procedures.	

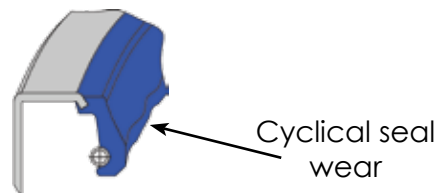
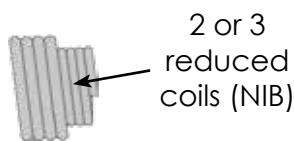

C.3.1 Shaft Diameter

Probable Causes	Action or Countermeasures
1. Oversize shaft may accelerate lip wear, increase heat generation, shaft wear may cause lip to invert during installation	Replace shaft, or, if oversize, machine to proper diameter.
2. Undersize shaft may result in insufficient lip interference to seal properly, resulting in premature leakage.	

TROUBLE SHOOTING

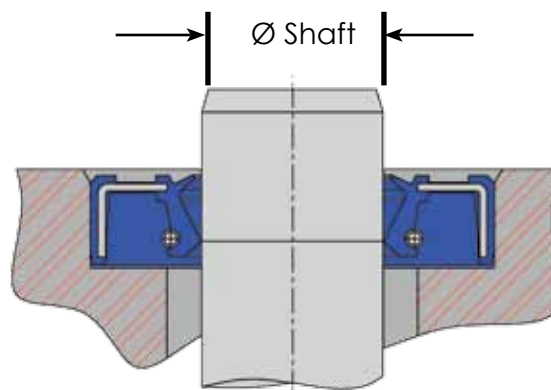

C.3.2 Shaft Surface Roughness (Primary Sealing Surface)

Probable Causes	Action or Countermeasures
1. Excessively rough shaft may accelerate lip wear and if too rough, leak upon initial startup	Replace shaft or, if oversize, machine to proper diameter
2. Undersize shaft may result in insufficient lip interference to seal properly, resulting in early leakage	

C.3.3 Shaft Corrosion

Probable Causes	Action or Countermeasures
1. Corrosion on the shaft in the area of the lip contact will interfere with lip's ability to seal against the shaft surface properly. The increased surface roughness may provide leakage paths and lip wear may increase from higher roughness	Apply corrosion-resistant shaft material
	Use Replaceable corrosion-resistant shaft sleeve
	Change assembly design to limit access of corrosive contaminants
	Change to seal design that will protect shaft from corrosion so lip can function normally.
	If corrosion from inventory storage before assembly- change inventory system.

TROUBLE SHOOTING

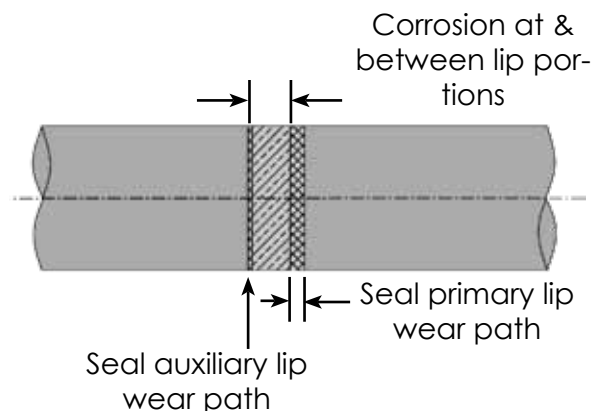

C.3.4 Lip Wear Band in Wrong Location on Shaft

Probable Causes	Action or Countermeasures
1. Insufficient/excessive lip interference may occur affecting lip's ability to seal.	Make sure proper seal is used (width to specs?)
2. Improper seal of seal lip may contact shaft resulting in high temperature or leakage due to improper lip orientation	Make sure seal installed to proper depth (not too deep/shallow) installation tool/procedure may be revised to ensure proper depth. Check shaft or assembly per specs
4. Seal moving after installation	Check install method, seal and bore diameter
5. Metal case of seal deformed during installation.	May orientate lip improperly.

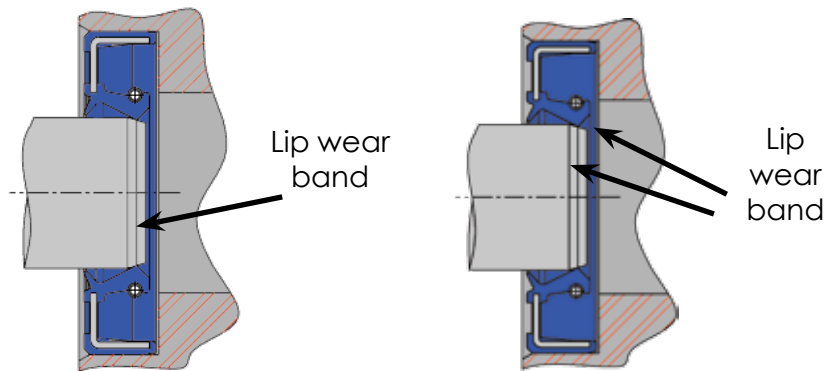

TROUBLE SHOOTING

C.3.5 Scratches or Nicks at Lip Contact Area on Shaft

Probable Causes	Action or Countermeasures
<ol style="list-style-type: none"> 1. Scratches or nicks (if large enough) across the seal contact area of shaft act as leakage paths. 2. Shaft damaged during actual assembly. 3. Worker mishandling causing damage. 	<p>Check handling procedures of shaft from time shaft is machined until it reaches assembly area special carrying trays that protect shafts from hitting each other area suggested. Special cardboard or nylon mesh sleeves are commonly used.</p> <p>May require assembly method or jig change.</p> <p>Improve handling method</p> <p>It may be possible to rework shaft to remove defect but shaft roughness or diameter should not be altered outside of design spec.</p> <p>Harden shaft to minimum RC 45 to improve resistance to scratching or nicking.</p>

TROUBLE SHOOTING

C.3.6 Excessive Shaft Wear

Probable Causes	Action or Countermeasures
<p>1. Seal lip will have difficulty sealing against the shaft wear band if depth is too large or width is too wide.</p>	<p>Check shaft hardness, may get harder shaft</p> <p>Outside contaminant ingestion may cause problem. Use contaminant-resistant design.</p> <p>Improper lubrication can cause accelerated shaft wear. Check lube compatibility with lip and quantity of lubricant reaching seal.</p>
<p>4. Contaminant present in fluid to be sealed.</p>	<p>Check compatibility and change fluid more frequently or filter more effectively.</p> <p>Proper lip interference. Check shaft diameter and seal to make sure to specs.</p>
<p>6. Excessive eccentricity can cause unusual wear.</p>	<p>Check for excessive runout or shaft to bore misalignment.</p>

TROUBLE SHOOTING

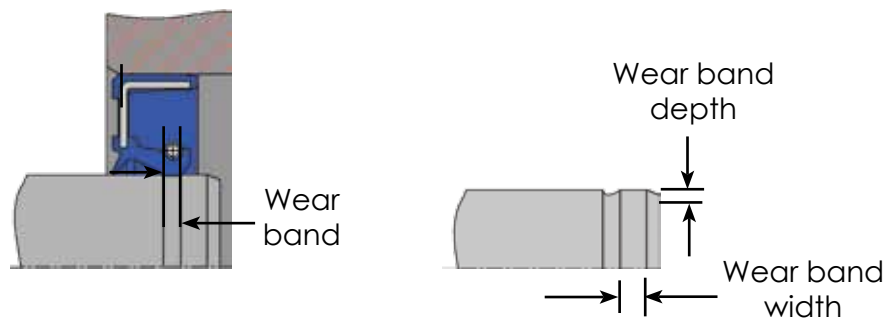

C.3.7 Wide Shaft Wear Band Relative to Seal Wear Band

Probable Causes	Action or Countermeasures
1. Leakage may result prematurely as lip cannot maintain proper orientation against the shaft	Check for seal cocking and correct installation procedure if found.
2. Leakage may occur as wide shaft wear band may act as leakage path.	Excessive axial motion can cause this type of wear. Check assembly and replace bearing if defective or worn.

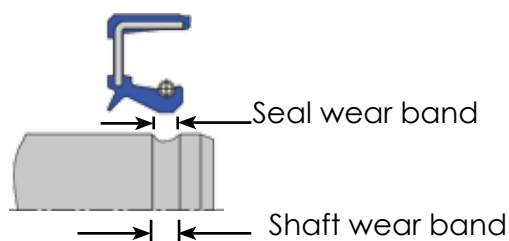

TROUBLE SHOOTING

C.3.8 Shaft Discoloration or Coked Oil on Shaft

Probable Causes	Action or Countermeasures
1. Discoloration may indicate excessively high temperatures. The high temperatures may affect other characteristics of seal (lip hardness) resulting in premature failure.	Check quantity of lubricant reaching seal and increase if necessary.
2. Coked oil buildup will interfere with the seal lip's ability to contact shaft which will result in failure	Was shaft diameter or lip ID causing too much interference? Change to reduce interference.
3. Bearing preload too high causing temperatures in seal area to be very high.	Set bearing to proper preload.
4. Shaft too smooth causing seal to run hot.	Check shaft roughness.
5. Excessive pressures in seal cavity can load seal lip excessively against shaft causing high temperatures.	Reduce pressure or use pressure-resistant seal design. Change oil to high temperature resistant fluid. Reduce operating temperature of final assembly to range compatible with lube and seal material.

TROUBLE SHOOTING

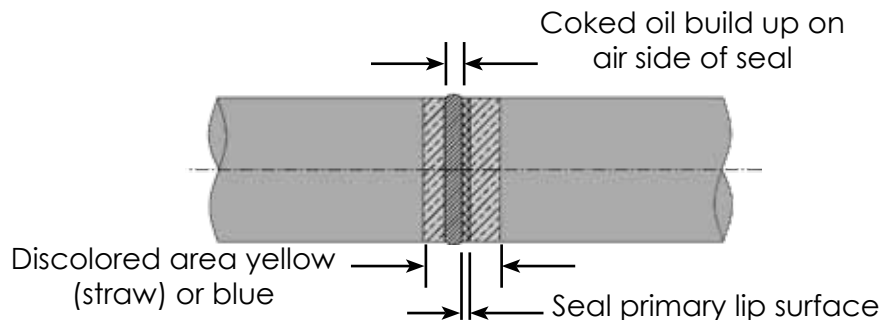

C.3.9 Machine Lead

Probable Causes	Action or Countermeasures
1. Machine lead may hydrodynamically pump medium to be sealed out, depending on shaft rotation direction.	Finish shaft as recommended in RMA document OS-1 to eliminate machine lead.

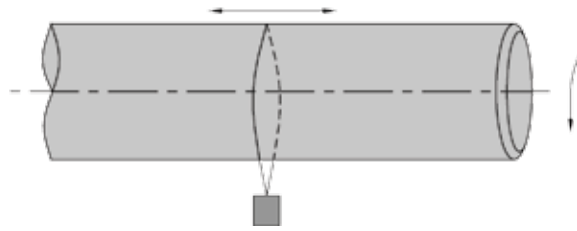

Shaft being checked for lead per procedure in OS-1

C.3.10 Shaft Hardness

Probable Causes	Action or Countermeasures
1. Shaft with hardness less than Rc 30 may experience accelerated wear, especially if sealing in a highly abrasive environment.	Harden shaft or use harder shaft material proper diameter.
2. Rc 45 is the preferred hardness if handling defects (scratches or nicks) are likely.	Use wear sleeve.
	Reduce amount of contaminants reaching seal by changing to contaminant-resistant seal design or changing assembly design to limit outside contaminants. Change fluid more frequently if inside contaminants. Using better wear resistant bearing, gear, or other metal components inside assembly will help reduce contaminants in lubricant.

TROUBLE SHOOTING

C.3.11 Shaft Chamfer Condition

Probable Causes	Action or Countermeasures
1. Insufficient chamfer may cause seal lip to invert, cause garter spring to pop off or make installation very difficult.	Apply proper shaft chamfer as recommended in RMA document OS-4.
2. Sharp edges or burrs may cut seal lip or cause lip to invert.	Use a shaft sleeve, mandrel or bullet to protect seal lip during installation.

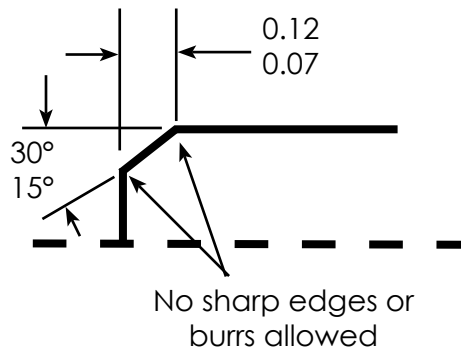

C.3.12 Proper Shaft Material

Probable Causes	Action or Countermeasures
1. Primary concern is achieving recommended shaft hardness and/or resistance to corrosion if in a highly corrosive environment.	Change shaft material to compatible material for application. Shaft wear sleeve may be applied.

TROUBLE SHOOTING

C.3.13 Wear Sleeve Fit

Probable Causes	Action or Countermeasures
1. Improper fit of the sleeve may result in a deformed sleeve.	Follow proper installation methods to insure sleeve is not damaged during installation.
2. Leakage may occur between sleeve ID and shaft diameter	Check shaft chamber for burrs or nicks or improper angle/depth and correct
3. If sleeve is loose, it may rotate separate from shaft resulting in excessive heat generation	Use additional sealant to prevent sleeve ID/shaft interface leakage Check shaft diameter OD/sleeve ID to see if correct-replace if necessary. Also, sealant such as loctite or permatex may prevent sleeve from spinning.

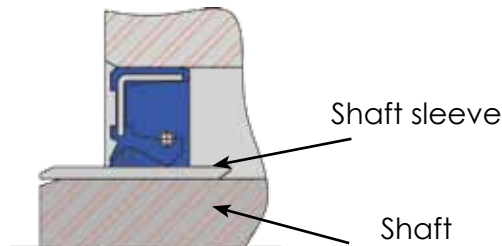

TROUBLE SHOOTING

C.4.1 Contaminants in Oil

Probable Causes	Action or Countermeasures
1. Inadequate cleaning of unit prior to assembly.	Review procedure to insure removal of machining debris prior to part assembly.
2. Ingestion of contaminants past seal.	Inspect seal for presence of exclusion lip. For spring load seal, check for spring.
3. Wear debris: e.g. bearing, shaft and other dynamic contact parts.	Inspect dynamic components for excessive wear.
4. Oil contamination during storage	Check storage procedures for bulk oil supply.
5. Oil contamination by vendor	Check in-house and incoming oil containers for contaminants.
6. Break-down of hydraulic hoses and similar system components due to material deterioration	Check material fluid compatibility.
7. Sabotage	Install tamper-proof fill cap.
8. Worn seal	Replace oil, filter oil, and clean housing.
9. Sintered (powdered metal) components	

C.4.2 Composition of Lubricant Compared to New

Probable Causes	Action or Countermeasures
1. Changes in fluid lubricity, viscosity	Send oil sample to vendor for analysis
2. Apparent color differences	Send oil sample to vendor for analysis
3. Noticeable odor difference	Send oil sample to vendor for analysis
4. Noncompatible "substitute" fluid	Use fluid specified by OEM
5. Contaminates in fluid	Replace fluid; filter fluid

TROUBLE SHOOTING

RADIAL SHAFT SEAL PART NUMBERING SYSTEM

INCH SIZE

Radial shaft seals are manufactured in a large range of sizes and styles. To expedite the ordering process a straightforward part numbering system has been developed. Following is a detailed description of this system.

The part number is composed of the seal profile, shaft diameter, bore diameter, width of seal, O.D. treatment (ODT), lip material, case material and spring material. Below is a representation of how the part number is assembled.

Profile - Shaft Bore Width - ODT Lip Case Spring

- Profile: Selected from Profile Matrix, e.g. TB2, UB2
- Shaft: The diameter of shaft where the seal will operate
- Bore: The diameter of bore where the seal will operate
- Width: the width of the seal case
- ODT: Outside Diameter Treatment
 - : OD sealant (standard)
 - G: Ground OD
 - (Sealant and ground are the only options on metal OD radial shaft seals)
- Lip: Material of primary sealing element
 - N: Nitrile
 - T: Polytetrafluoroethylene (Teflon)
 - F: Fluorocarbon (Viton)
 - P: Polyacrylate
 - S: Silicone
 - E: Ethylene Propylene (EPDM)
 - H: High Temperature Nitrile
 - X: Carboxylated Nitrile

ORDER
INFORMATION

- Case: Case material
C: Carbon steel (1008-1010)
S: Stainless steel (30304)
- Spring: Spring material
C: Carbon steel (1070-1090)
S: Stainless steel (30304)

EXAMPLES:

Typical Part Number

TB2-087513750313-NCC

This is profile TB2 for a 0.875" shaft, 1.375" bore and 0.313" width with OD sealant, nitrile for the primary sealing lip, carbon steel case and carbon steel spring.

Ground OD

SA2-225032510375-GPSS

This is profile SA2 for a 2.250" shaft, 3.251" bore, and 0.375" width with a ground OD, polyacrylate primary sealing lip, stainless steel case, and stainless steel spring.

Hydrodynamic Aid

HSCJR-125022500250-XCS

An "H" is placed in front of the profile designation when a hydrodynamic aid is molded into the lip. The design of the hydrodynamic aid immediately follows the profile designation.

This is profile SCJ with type "R" hydrodynamic aid for a 1.250" shaft, 2.250" bore, and 0.250" width. The seal has a carboxylated nitrile primary sealing lip, carbon steel case and stainless steel spring.

**ORDER
INFORMATION**

METRIC SIZE LIST

Radial shaft seals are manufactured in a large range of sizes and styles. To expedite the ordering process a straightforward part numbering system has been developed. Following is a detailed description of this system.

The part number is composed of the seal profile, shaft diameter, bore diameter, width of seal, OD treatment (ODT), lip material, case material and spring material. Below is a representation of how the part number is assembled.

Profile - Shaft Bore Width - ODT Lip Case Spring

- Profile: Selected from Profile Matrix eg TB2, UB2
- Shaft: The diameter of shaft where the seal will operate.
- Bore: The diameter of bore where the seal will operate.
- Width: The width of the seal case.
- ODT: Outside diameter treatment
 - :OD sealant (standard)
 - G: Ground OD
 - (Sealant and Ground only an option on metal OD radial shaft seals)
- Lip: Material of primary sealing element.
 - N: Nitrile
 - T: Polytetrafluoroethylene (Teflon)
 - F: Fluorocarbon (Viton)
 - P: Polyacrylate
 - S: Silicone
 - E: Ethylene Propylene (EPDM)
 - H: High Temperature Nitrile
 - X: Carboxilated Nitrile

ORDER
INFORMATION

- Case: Case material
C: Carbon steel (1008-1010)
S: Stainless steel (30304)
- Spring: Spring material
C: Carbon steel (1070-1090)
S: Stainless steel (30304)

EXAMPLES

Typical Part Number

TB2-02102800070-NCC

This is profile TB2 for a 21.0 mm shaft, 28.0 mm bore and 7.0 mm width with OD sealant, nitrile for the primary sealing lip, carbon steel case and carbon steel spring.

Ground OD

SA2-035006500120-GPSS

This is profile SA2 for a 35.0 mm shaft, 65.0 mm bore, and 12. Mm width with a ground OD, polyacrylate primary sealing lip, stainless steel case, and stainless steel spring.

Hydrodynamic Aid

HSCJR-080011000100-XCS

An "H" is placed in front of the profile designation when a hydrodynamic aid is molded into the lip. The design of the hydrodynamic aid immediately follows the profile designation.

This is profile SCJ with type "R" hydrodynamic aid for a 80.0 mm shaft, 110.0 mm bore, and 10.0 mm width. The seal has a carboxylated nitrile primary sealing lip, carbon steel case, and stainless steel spring.

**ORDER
INFORMATION**

RELATION BETWEEN SHAFT DIAMETER, FPM, MPM AND RPM

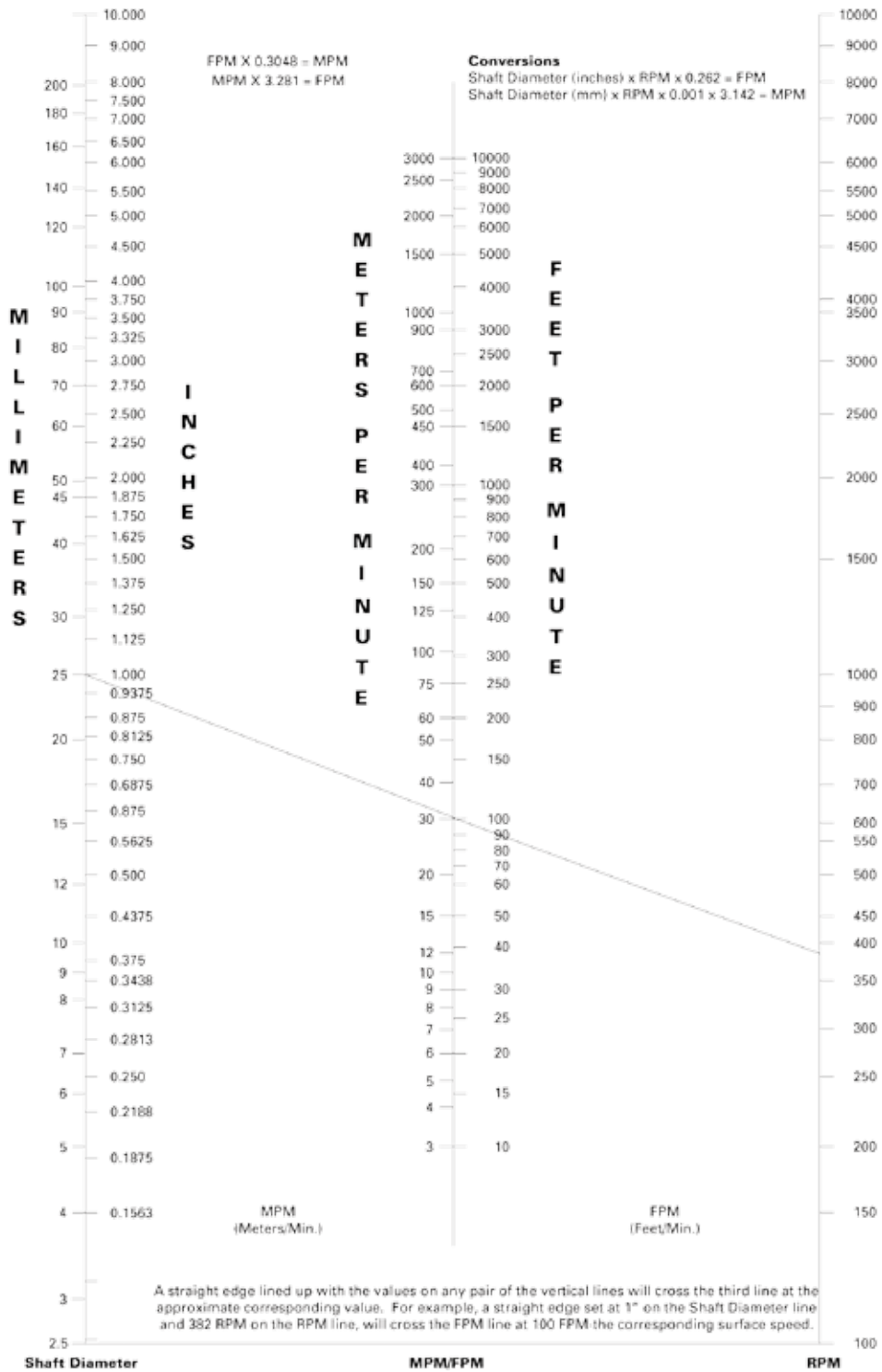

REFERENCE

DECIMAL & MILLIMETER EQUIVALENTS

Decimals		Millimeters		Decimals		Millimeters	
$\frac{1}{64}$	0.015625	—	0.397	$\frac{33}{64}$	0.515625	—	13.097
$\frac{1}{32}$	0.03125	—	0.794	$\frac{17}{32}$	0.53125	—	13.494
$\frac{3}{64}$	0.046875	—	1.191	$\frac{35}{64}$	0.546875	—	13.891
$\frac{1}{16}$	0.0625	—	1.588	$\frac{9}{16}$	0.5625	—	14.288
$\frac{5}{64}$	0.078125	—	1.984	$\frac{37}{64}$	0.578125	—	14.684
$\frac{3}{32}$	0.09375	—	2.381	$\frac{19}{32}$	0.59375	—	15.081
$\frac{7}{64}$	0.109375	—	2.778	$\frac{39}{64}$	0.609375	—	14.478
$\frac{1}{8}$	0.1250	—	3.175	$\frac{5}{8}$	0.6250	—	15.875
$\frac{9}{64}$	0.140625	—	3.572	$\frac{41}{64}$	0.640625	—	16.272
$\frac{5}{32}$	0.15625	—	3.969	$\frac{21}{32}$	0.65625	—	16.669
$\frac{11}{64}$	0.171875	—	4.366	$\frac{43}{64}$	0.671875	—	17.066
$\frac{3}{16}$	0.1875	—	4.763	$\frac{11}{16}$	0.6875	—	17.463
$\frac{13}{64}$	0.203125	—	5.159	$\frac{45}{64}$	0.703125	—	17.859
$\frac{7}{32}$	0.21875	—	5.556	$\frac{23}{32}$	0.71875	—	18.256
$\frac{15}{64}$	0.234375	—	5.953	$\frac{47}{64}$	0.734375	—	18.653
$\frac{1}{4}$	0.2500	—	6.350	$\frac{3}{4}$	0.7500	—	19.050
$\frac{17}{64}$	0.265625	—	6.747	$\frac{49}{64}$	0.765625	—	19.447
$\frac{9}{32}$	0.28125	—	7.144	$\frac{25}{32}$	0.78125	—	19.844
$\frac{19}{64}$	0.296875	—	7.541	$\frac{51}{64}$	0.796875	—	20.241
$\frac{5}{16}$	0.3125	—	7.938	$\frac{13}{16}$	0.8125	—	20.638
$\frac{21}{64}$	0.328125	—	8.334	$\frac{53}{64}$	0.828125	—	21.034
$\frac{11}{32}$	0.34375	—	8.731	$\frac{27}{32}$	0.84375	—	21.431
$\frac{23}{64}$	0.359375	—	9.128	$\frac{55}{64}$	0.859375	—	21.828
$\frac{3}{8}$	0.3750	—	9.525	$\frac{7}{8}$	0.8750	—	22.225
$\frac{25}{64}$	0.390625	—	9.922	$\frac{57}{64}$	0.890625	—	22.622
$\frac{13}{32}$	0.40625	—	10.319	$\frac{29}{32}$	0.90625	—	23.019
$\frac{27}{64}$	0.421875	—	10.716	$\frac{59}{64}$	0.921875	—	23.416
$\frac{7}{16}$	0.4375	—	11.113	$\frac{15}{16}$	0.9375	—	23.813
$\frac{29}{64}$	0.453125	—	11.509	$\frac{61}{64}$	0.953125	—	24.209
$\frac{15}{32}$	0.46875	—	11.906	$\frac{31}{32}$	0.96875	—	24.606
$\frac{31}{64}$	0.484375	—	12.303	$\frac{63}{64}$	0.984375	—	25.003
$\frac{1}{2}$	0.5000	—	12.700	$\frac{1}{1}$	1.000	—	25.400

1 mm= 0.03937"

0.001"=0.0254 mm

REFERENCE

CONVERSION FACTORS

Prefixes for SI Units	Symbol = Prefix	Factor by which unit is multiplied
	T = tera	10^{12}
	G = giga	10^9
	M = mega	10^6
	k = kilo	10^3
	h = hecto	10^2
	da = deka	10
	d = deci	10^{-1}
	c = centi	10^{-2}
	m = milli	10^{-3}
	μ = micro	10^{-6}
	n = nano	10^{-9}
p = pico	10^{-12}	
f = femto	10^{-15}	
a = atto	10^{-18}	
Mass	1 kg = 2.2046 lb _m 1 g = 2.2046 x 10 ⁻³ lb _m 1 slug = 14.59 kg	1 lb _m = 0.4536 kg 1 lb _m = 453.6 g 1 kg = 0.06852 slug
Density	1 kg / m ³ = 0.0624 lb _m / ft ³ 1 g / cm ³ = 62.4 lb _m / ft ³ 1 g / cm ³ = 0.0361 lb _m / in ³ 1 slug / ft ³ = 515.4 kg / m ³	1 lb _m / ft ³ = 16.02 kg / m ³ 1 lb _m / ft ³ = 1.602 x 10 ⁻² g / cm ³ 1 lb _m / in ³ = 27.7 g / cm ³ 1 kg / m ³ = 0.00194 slug / ft ³
Length	1 mm = 0.03937 in 1 m = 3.2808 ft	1 in = 25.4 mm 1 ft = 0.3048 m
Velocity	1 m / s = 3.281 ft / s 1 km / h = 0.9113 ft / s 1 km / h = 0.62137 mile / h	1 ft / s = 0.3048 m / s 1 ft / s = 1.097 km / h 1 mile / h = 1.6093 km / h
Volume	1 m ³ = 1000 liters 1 m ³ = 61,020 in ³ 1 m ³ = 35.31 ft ³ 1 m ³ = 264.2 gal 1 gal = 231.0 in ³ 1 gal = 0.1337 ft ³ 1 in ³ = 578 x 10 ⁻⁶ ft ³	1 liter = 0.001m ³ 1 in ³ = 16.39 x 10 ⁻⁶ m ³ 1 ft ³ = 0.02832 m ³ 1 gal = 0.003785 m ³ 1 in ³ = 0.004329 gal 1 ft ³ = 7.481 gal 1 ft ³ = 1728 in ³
Flow Rate	1 gal / min = 0.06309 liters / s 1 gal / min = 0.002228 ft ³ / s 1 liter / s = 0.03531 ft ³ / s	1 liter / s = 15.85 gal / min 1 ft ³ / s = 448.8 gal / min 1 ft ³ / s = 28.32 liters / s
Force	1 N = 1 kg · m / s ² 1 N = 10 ⁵ dynes 1 N = 0.22481 lb _f	1 kip = 1000 lb _f 1 lb _f = 32.174 lb _m · ft / s ² 1 dyne = 10 ⁻⁵ N 1 lb _f = 4.4482 N

REFERENCE

CONVERSION FACTORS

Energy	1 J = 1 N · m	1 Btu = 778.17 ft · lb _f
	1 J = 0.73756 ft · lb _f	1 ft · lb _f = 1.35582 J
	1 kJ = 0.9478 Btu	1 Btu = 1.0551 kJ
		1 kcal = 4.1868 kJ
Pressure	1 Pa = 1 N / m ²	1 ksi = 1000 lb _f / in ²
	1 bar = 10 ⁵ N / m ²	1 lb _f / in ² = 144 lb _f / ft ²
	1 Pa = 1.4504 x 10 ⁻⁴ lb _f / in ²	1 lb _f / in ² = 6894.8 Pa
	1 MPa = 145 lb _f / in ²	1 lb _f / in ² = 6.90 x 10 ⁻³ MPa
	1 atm = 1.01325 bar	1 atm = 14.696 lb _f / in ²
Power	1 W = 1 J / s	1 hp = 2545 Btu / h
	1 W = 3.413 Btu / h	1 Btu / h = 0.293 W
	1 kW = 1.341 hp	1 hp = 0.7457 kW
		1 hp = 550 ft · lb _f / s
Temp.	T(K) = 273.15 + T(°C)	T(°C) = T(K) - 273.15
	T(K) = 5/9[T(°F) - 32] + 273.15	T(°F) = 9/5[T(K) - 273] + 32
	T(°C) = 5/9[T(°F) - 32]	T(°F) = 9/5[T(°C)] + 32
	T(°R) = 459.67 + T(°F)	T(°F) = T(°R) - 459.67
Specific Heat	1 kJ / kg · K = 0.238846 Btu / lb _m · °R	1 Btu / lb _m · °R = 4.1868 kJ / kg · K
	1 kcal / kg · K = 1 Btu / lb _m · °R	
Thermal Conductivity	1 W / m · K = 2.39 x 10 ⁻³ cal / cm · s · K	1 cal / cm · s · K = 418.4 W / m · K
	1 W / m · K = 0.578 Btu / ft · h · °F	1 Btu / ft · h · °F = 1.730 W / m · K
	1 cal / cm · s · K = 241.8 Btu / ft · h · °F	1 Btu / ft · h · °F = 4.136 x 10 ⁻³ cal / cm · s · K
Universal Gas Constant		R = 8.314 kJ / kmol · K
		R = 1545 ft · lb _f / lbmol · °R
		R = 1.986 Btu / lbmol · °R
Standard Acceleration of Gravity		g = 9.80665 m / s ²
		g = 32.174 ft / s ²
Standard Atmospheric Pressure		1 atm = 1.01325 bars
		1 atm = 14.696 lb _f / in ²

REFERENCE

EQUATIONS FROM GEOMETRY

Triangle

$$h = a \sin \theta$$

$$\text{Area} = 1/2bh$$

(Law of Cosines)

$$c^2 = a^2 + b^2 - 2ab \cos \theta$$

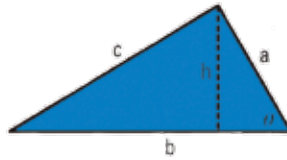

Sector of Circular Ring

(p = average radius,
w = width of ring,

θ in radians)

$$\text{Area} = \theta pw$$

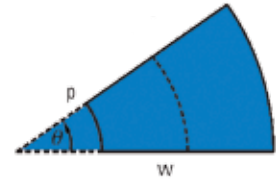

Right Triangle

(Pythagorean Theorem)

$$c^2 = a^2 + b^2$$

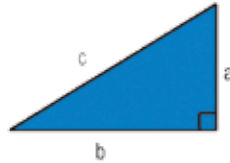

Ellipse

$$\text{Area} = \pi ab$$

$$\text{Circumference} \approx 2\pi \sqrt{\frac{a^2 + b^2}{2}}$$

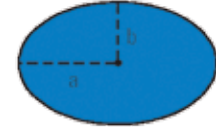

Equilateral Triangle

$$h = \frac{\sqrt{3}s}{2}$$

$$\text{Area} = \frac{\sqrt{3}s^2}{4}$$

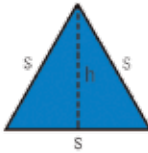

Cone

(A = area of base)

$$\text{Volume} = \frac{Ah}{3}$$

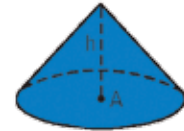

Parallelogram

$$\text{Area} = bh$$

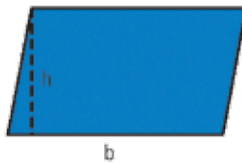

Right Circular Cone

$$\text{Volume} = \frac{\pi r^2 h}{3}$$

$$\text{Lateral Surface Area} = \pi r \sqrt{r^2 + h^2}$$

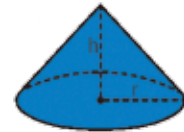

Trapezoid

$$\text{Area} = \frac{h}{2}(a + b)$$

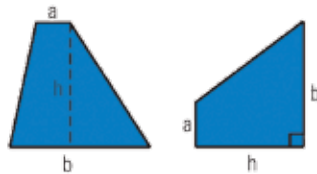

Frustum of Right Circular Cone

$$\text{Volume} = \frac{\pi(r^2 + rR + R^2)h}{3}$$

$$\text{Lateral Surface Area} = \pi s(R + r)$$

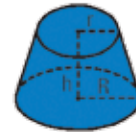

Circle

$$\text{Area} = \pi r^2 = \frac{\pi d^2}{4}$$

$$\text{Circumference} = 2\pi r = \pi d$$



Right Circular Cylinder

$$\text{Area} = \pi r^2 h$$

$$\text{Lateral Surface Area} = 2\pi rh$$



Sector of Circle

(θ in radians)

$$\text{Area} = \frac{\theta r^2}{2}$$

$$s = r\theta$$

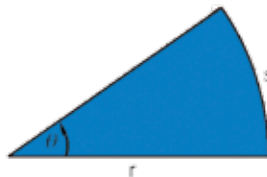

Sphere

$$\text{Volume} = \frac{4}{3} \pi r^3$$

$$\text{Surface Area} = 4\pi r^2$$



REFERENCE

Circular Ring

(p = average radius,
w = width of ring)

$$\text{Area} = \pi(R^2 - r^2) = 2\pi pw$$



Wedge

(A = area of upper face,
B = area of base)

$$A = B \sec \theta$$

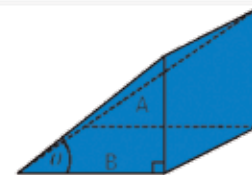

REFERENCE MATERIALS

Approximate Physical Properties of Some Common Liquids (BG Units)

Liquid	Temperature (°F)	Density, ρ (slugs/ft³)	Specific Weight, γ (lb/ft³)	Dynamic Viscosity, μ (lb/ft²)	Kinematic Viscosity, ν (ft²/s)	Surface Tension, σ (lb/ft)	Vapor Pressure, P _v (lb/in² (abs))	Bulk Modulus, E _v (lb/in²)
Carbon tetrachloride	68	3.09	99.5	2.00 E - 5	6.47 E - 6	1.84 E - 3	1.9 E + 0	1.91 E + 5
Ethyl alcohol	68	1.53	49.3	2.49 E - 5	1.63 E - 3	1.56 E - 3	8.5 E - 1	1.54 E + 5
Gasoline ^c	60	1.32	42.5	6.5 E - 6	4.9 E - 6	1.5 E - 3	8.0 E + 0	1.9 E + 5
Glycerin	68	2.44	78.6	3.13 E - 2	1.28 E - 2	4.34 E - 3	2.0 E - 6	6.56 E + 5
Mercury	68	26.3	847	3.28 E - 5	1.25 E - 6	3.19 E - 2	2.3 E - 5	4.14 E + 6
SAE 30 oil ^c	60	1.77	57.0	8.0 E - 3	4.5 E - 3	2.5 E - 3		2.2 E + 5
Seawater	60	1.99	64.0	2.51 E - 5	1.26 E - 5	5.03 E - 3	2.56 E - 1	3.39 E + 5
Water	60	1.94	62.4	2.34 E - 5	1.21 E - 5	5.03 E - 3	2.56 E - 1	3.12 E + 5

^aIn contact with air

^bIsentropic bulk modulus calculated from speed of sound

^cTypical values. Properties of petroleum products vary.

Approximate Physical Properties of Some Common Liquids (SI Units)

Liquid	Temperature (°C)	Density, ρ (kg/m³)	Specific Weight, γ (kN/m³)	Dynamic Viscosity, μ (N x s/m²)	Kinematic Viscosity, ν (m²/s)	Surface Tension, σ (N/m)	Vapor Pressure, P _v (N/m² (abs))	Bulk Modulus, E _v (N/m²)
Carbon tetrachloride	20	1,590	15.6	9.58 E - 4	6.03 E - 7	2.69 E - 2	1.3 E + 4	1.31 E + 9
Ethyl alcohol	20	789	7.74	1.19 E - 3	1.51 E - 6	2.28 E - 2	5.9 E + 3	1.06 E + 9
Gasoline ^c	15.6	680	6.67	3.1 E - 4	4.6 E - 7	2.2 E - 2	5.5 E + 4	1.3 E + 9
Glycerin	20	1,260	12.4	1.50 E + 0	1.19 E - 3	6.33 E - 2	1.4 E - 2	4.52 E + 9
Mercury	20	13,600	133	1.57 E - 3	1.15 E - 7	4.66 E - 1	1.6 E - 1	2.85 E + 10
SAE 30 oil ^c	15.6	912	8.95	3.8 E - 1	4.2 E - 4	3.6 E - 2		1.5 E + 9
Seawater	15.6	1,030	10.1	1.20 E - 3	1.17 E - 6	7.34 E - 2	1.77 E + 3	2.34 E + 9
Water	15.6	999	9.80	1.12 E - 3	1.12 E - 6	7.34 E - 2	1.77 E + 3	2.15 E + 9

^aIn contact with air

^bIsentropic bulk modulus calculated from speed of sound

^cTypical values. Properties of petroleum products vary.

REFERENCE

Approximate Physical Properties of Some Common Gases at Standard Atmospheric Pressure (BG Units)

Gas	Temperature (°F)	Density, ρ (slugs/ft ³)	Specific Weight, γ (lb/ft ³)	Dynamic Viscosity, μ (lb*s/ft ²)	Kinematic Viscosity, ν (ft ² /s)	Gas Constant, °R (ft*lb/slug*°R)	Specific Heat Ratio, ^b κ
Air (standard)	59	2.38 E-3	7.65 E-2	3.74 E-7	1.57 E-4	1.716 E+3	1.40
Carbon dioxide	68	3.55 E-3	1.14 E-1	3.07 E-7	8.65 E-5	1.130 E+3	1.30
Helium	68	3.23 E-4	1.04 E-2	4.09 E-7	1.27 E-3	1.242 E+4	1.66
Hydrogen	68	1.63 E-4	5.25 E-3	1.85 E-7	1.13 E-3	2.466 E+4	1.41
Methane (natural gas)	68	1.29 E-3	4.15 E-2	2.29 E-7	1.78 E-4	3.099 E+3	1.31
Nitrogen	68	2.26 E-3	7.28 E-2	3.68 E-7	1.63 E-4	1.775 E+3	1.40
Oxygen	68	2.58 E-3	8.31 E-2	4.25 E-7	1.65 E-4	1.554 E+3	1.40

^aValues of the gas constant are independent of temperature

^bValues of the specific heat ratio depend only slightly on temperature.

Approximate Physical Properties of Some Common Gases at Standard Atmospheric Pressure (SI Units)

Gas	Temperature (°C)	Density, ρ (kg/m ³)	Specific Weight, γ (N/m ³)	Dynamic Viscosity, μ (N*s/m ²)	Kinematic Viscosity, ν (m ² /s)	Gas Constant, °R (J/kg*K)	Specific Heat Ratio, ^b κ
Air (standard)	15	1.23 E+0	1.20 E+1	1.79 E-5	1.46 E-5	2.869 E+2	1.40
Carbon dioxide	20	1.83 E+0	1.80 E+1	1.47 E-5	8.03 E-6	1.889 E+2	1.30
Helium	20	1.66 E-1	1.63 E+0	1.94 E-5	1.15 E-4	2.077 E+3	1.66
Hydrogen	20	8.38 E-2	8.22 E-1	8.84 E-6	1.05 E-4	4.124 E+3	1.41
Methane (natural gas)	20	6.67 E-1	6.54 E+0	1.10 E-5	1.65 E-5	5.183 E+2	1.31
Nitrogen	20	1.16 E+0	1.14 E+1	1.76 E-5	1.52 E-5	2.968 E+2	1.40
Oxygen	20	1.33 E+0	1.30 E+1	2.04 E-5	1.53 E-5	2.598 E+2	1.40

^aValues of the gas constant are independent of temperature

^bValues of the specific heat ratio depend only slightly on temperature.

GLOSSARY

A

Air Side:	The side of a seal that normally faces away from the fluid being sealed.
Air Side Angle:	The angle between the air-side surface and the shaft. Also barrel angle.
Angle, Contact Approach:	See angle, outside lip.
Angle, Helix:	The angle between a helical rib and the lip line of contact.
Angle, Helix Contact:	The angle formed by the rib leading edge and the lip line of contact.
Angle, Helixseal Rib:	The angle formed by the leading edge of the rib and a line perpendicular to a plane tangent to the outside lip surface at the centerline of the rib base.
Angle, Inside Lip:	The angle between the inside lip surface and the axis of the seal case.
Angle, Molded Toe:	The angle between the toe face of a seal lip and the seal axis.
Angle, Outside Lip:	The angle between the outside lip surface and the axis of the seal case.
Angle, Trimming:	The angle between the trimmed face of a seal lip and the seal axis.
Assembly, Seal:	A group of parts that includes sealing surfaces, provisions for initial loading and a secondary sealing mechanism, which accommodates the radial and axial movement necessary for installation.
Axial Clearance:	See Clearance, Axial.

B

Base, Seal:	See Face, Outside Seal.
Bedding-In:	See Run-in.
Bell Mouth:	A condition where the contact between the sealing element and the shaft occurs on the air side of the seal and not on the seal tip.
Blister:	A raised cavity or sack that deforms a surface of the seal material.

REFERENCE

Bond:	The adhesion established by vulcanization between two cured elastomer surfaces, or between one cured elastomer surface and one nonelastomer surface.
Bore, Housing:	A cylindrical surface that mates with the outside diameter of the outer seal case.
Bore, Seal Case:	See Diameter, Outer-Case Inner.
Buna-N:	See Nitrile.

C

Cap:	The part of the seal head section that is removed during trimming.
Case, Bonded:	A design feature of a type of radial lip seal where in the heel of the sealing element is attached to the seal case by an adhesive during the molding operation.
Case, Clinched:	A design feature of a type of radial lip wherein the heel of the sealing element is attached to the seal case by clamping it between two convolutions, or folds, of the case.
Case, Inner:	A rigid, cup-shaped component of a seal assembly that is placed inside the outer seal case. It has one or more of the following functions: reinforcing member, shield, spring retainer or lip-clamping device.
Checking:	Short axial cracks on the lip contact surface.
Clearance, Axial:	The gap between the toe face of the head sections and the inside surface of the inner case.
Cocked Assembly:	An installation in which the plane of the outside seal face is not perpendicular to the shaft axis.
Coil:	One turn of the coiled wire garter spring.
Composite:	A seal element comprised of two or more compounds bonded together to enhance seal performance and/or reduce costs.
Contact Line:	The circular line formed where the air side and oil side surface of the elastomeric lip element intersect. The contact line is a point when the seal element is viewed in cross-section.

REFERENCE

Contact Line Height:	The axial distance from the outside seal face to the lip contact line.
Case, Molded:	A design feature of a type of radial lip seal wherein the lip and case are made integral in the molding process.
Case, Outer:	The outer thin-wall rigid structure of the lip seal assembly which contains the inner case, the primary-seal ring, the spring parts and the secondary seal.
Case, Seal:	A rigid member to which the seal lip is attached.
Cavity, Mold:	A single unit or assembly of contoured parts in which a material, such as an elastomer, is shaped into a particular configuration.
Cavity, Seal:	The annular area between a housing bore and a shaft, into which a seal is installed.
Contact Point:	The area where the seal lip contacts the shaft.
Contact Width:	The axial dimension of the contact area that results when the seal is installed on the shaft.
Contamination:	Foreign matter on the seal surface.
Crack:	A sharp break or fissure in the sealing element.
Creep:	The time –dependent part of a strain resulting from stress.
Cure Time:	The time required to produce vulcanization at a given temperature.
Curing Temperature:	The temperature at which the elastomeric product is vulcanized.
Cut:	A deep discontinuity in the seal material whereby no material is removed.
Cut, Trim:	Damage to the elastomeric portion of the seal during trimming.

D

Deformation:	A stress induced change of form or shape.
Diameter Assembled Spring Inside:	Assembled spring inside the inner diameter of the garter spring with the ends securely joined.
Diameter, Free-Lip:	See Diameter, Unsprung Lip

REFERENCE

Diameter, Functional Lip:	The apparent inner diameter of the seal lip when the seal case is concentric with the outer diameter of the sizing mandrel in an air gauge, light box or similar inspection equipment.
Diameter, Inside Face Inner:	The inner diameter of the inner case of a radial lip seal.
Diameter, Lip:	The inner diameter of the seal lip, measured with the spring installed.
Diameter, Lip-Inner:	The inside, or smallest, diameter of the outer case on a lip-seal assembly.
Diameter, Seal Outer:	The external diameter of a lip-seal assembly, which normally corresponds to the outer diameter of the outer seal case.
Diameter, Spring Mean Coil:	The spring coil diameter minus the spring wire diameter.
Diameter, Spring Outside Coil:	The outer diameter of an individual helical coil of a garter spring.
Diameter, Trimmed Lip:	The lip diameter in the free state (no spring) developed by knife trimming the molded portion of the sealing element to form the contact line.
Diameter, Unsprung Lip:	The inner diameter of the seal lip, measured without the spring installed.
Dimension, Radial Wall:	The distance between the seal lip contact line and the seal outside diameter measured in a radial direction on a finished seal in the free state.
Dry Running:	Operation of a seal without lubrication at the seal-shaft interface.
Durometer:	An instrument which measures the hardness of rubber by the penetration (without puncturing) of an indenter point into the surface of rubber.

E

REFERENCE

Eccentricity, Lip ID to OD:	See Variation, Radial Wall.
Eccentricity, Shaft:	The radial distance which the geometric center of a shaft is displaced from the axis of shaft rotation.
Elasticity:	The property of a material which causes it to return to its original shape after deformation.

Elastomer:	An elastic rubberlike substance, such as natural or synthetic rubber.
Element, Sealing:	See Lip, Seal.
Elongation:	The increase in length of a specimen due to a tensile force expressed as a percentage of the original specimen length
End Play:	A measure of axial movement encountered or allowed, usually in reference to the shaft on which the seal lip contacts.
Extrusion:	Permanent displacement of part of a seal into a gap, under the action of fluid pressure.

F

FPM:	Feet per minute, used as a measure of shaft speed instead of RPM. To convert RPM to FPM use the formula $0.262 \times \text{RPM} \times \text{diameter (inches)} = \text{FPM}$
Face, Inside:	The surface of the inner case which faces, and is usually in contact with, the fluid being sealed.
Face, Molded Toe:	See Face, Toe.
Face, Outside:	The surface of the seal case, perpendicular to the shaft axis, which is not in contact with the fluid being sealed.
Face, Rib Leading:	The face of the helix seal rib which is closest to the fluid side of the seal.
Face, Toe:	The annular surface of the spring retaining lip.
Face, Trim:	The seal inside lip surface when formed by a trimming operation.
Factor, pv:	An arbitrary term which is the product of face pressure and relative sliding velocity. The term is normally considered to provide some measure of severity of service or seal life.
Filler:	A solid compounding ingredient which may be added usually in finely divided form, in relatively large proportions, to a polymer.
Finish, Shaft Surface:	See Texture, Shaft Surface.
Flash:	Thin extrusions of the elastomer formed by extrusion at the parting lines in the mold cavity or vent points.

REFERENCE

Flashing:	A rapid change in fluid state, from liquid to gaseous. In a dynamic seal, this can occur when frictional energy is added to the fluid as the latter passes between the primary sealing faces, or when fluid pressure is reduced below the fluid's vapor pressure because of a pressure drop across the sealing faces.
Flex Point:	Region where the seal lip will flex when the seal element is stretched over the shaft.
Flex Thickness:	The thickness of the region that flexes when the seal element is stretched over the seal.
Flexibility, Cold:	Flexibility of a material during exposure to a predetermined low temperature for a specific length of time.
Fluid Side:	The side of the seal which in normal use faces toward the fluid being sealed.
Fluoroelastomer:	A saturated polymer in which hydrogen atoms have been replaced with fluorine. It is characterized by excellent chemical and heat resistance.
Followability:	The ability of a seal lip to maintain a dam when the shaft has vibrations or dynamic runout.
Force, Lip:	The radial force exerted by an extension spring and/or lip of a seal on the mating shaft. Lip force is expressed as force per unit of shaft circumference.

G

Groove, Spring:	A depression formed in the head section of the seal. It is generally semicircular in form and serves to accommodate and locate the garter spring.
-----------------	---

H

Hardness:	The resistance to indentation. Measured by the relative resistance of the material to an indenter point of any one of a number of standard hardness testing instruments.
Hardness, Durometer:	An arbitrary numerical value which indicates the resistance to penetration of the indenter point into the rubber surface. Value may be taken immediately or after a very short specified time.

REFERENCE

Hardness, Shore:	The relative hardness of an elastomer obtained by use of a Shore durometer instrument.
Height, Contact Line:	The axial distance from the outside seal face to the lip contact line.
Height, Helix Seal Rib:	The height of the helical ribs, measured perpendicular to the outside lip surface.
Height, Lip:	The axial distance from the outside seal face to the toe face.
Housing:	A rigid structure which supports and locates the seal assembly with respect to the shaft.
Hydroseal:	A sealing system having helically disposed elements formed on the shaft surface.

I

Inclusion:	Foreign matter included in the seal material.
Incomplete Trim:	A trimmed surface which does not have all designated material removed.
Index, Spring:	The ratio of the mean coil diameter to the wire diameter of a garter spring to exclude contaminants.
Insert, Lip:	A material such as PTFE bonded onto a lip of an elastomeric seal to provide improved experiences the closest approach and effects the primary seal.
Interface:	The region between the static and dynamic sealing surfaces in which there is contact, or which experiences the closest approach and effects the primary seal.
Interference, Lip:	See Interference, Seal.
Interference, Seal:	The difference between the seal and shaft diameters.
International Rubber Hardness Degrees (IRHD):	A standard unit used to indicate the relative hardness of elastomeric materials, where zero represents a material having a Young's modulus of zero, and 100 represents a material of infinite Young's modulus.

K

Knit Line:	A blemish of the sealing element created by premature curing during molding operation.
------------	--

REFERENCE

L

Lead, Shaft:	Spiral grooves on a shaft surface caused by relative axial movement of grinding wheel to shaft.
Leakage:	See Rate, Leakage.
Length, Deflected:	Refers to the working circumferential length (measured on spring centerline) of the garter spring with the seal lip assembled on a normal (designed) shaft diameter.
Length, Lip:	The axial distance between the thinnest part of the flex section and the contact line.
Length, Spring Free:	The total unconfined length of a spring. For a garter spring, it would not include the rib length.
Life, Flex:	The length of time to failure which indicates the relative ability of a material to withstand dynamic bending or flexing under specific test conditions.
Line, Contact:	The line of intersection between the outside and inside lip surface of a radial lip seal. In a cross-sectional view, this intersection is illustrated as a point.
Lip, Axial Dirt:	A nonsprung axial lip at the heel of the elastomeric lip that impinges upon a radial flange and is used.
Lip, Auxiliary:	See Lip, Secondary Seal.
Lip, Dirt:	See Lip, Secondary Seal.
Lip Dust:	See Lip, Secondary Seal.
Lip, Molded:	A type of seal lip which requires no trimming to form the contact line.
Lip, Primary:	The normally flexible elastomeric component of a lip seal assembly, which rides against the rotating surface and affects the seal.
Lip, Static:	The section of the helix seal lip incorporating the contact line.
Lip, Secondary:	A short, nonspring-loaded lip, located at the outside seal face of a radial lip seal to prevent ingress of atmospheric contaminants.
Lip, Spring Retaining:	The portion of the primary lip that restricts the axial movement of the extension spring from a predetermined position.

REFERENCE

Load, Radial:	The total force (load) acting on the seal lip which tends to maintain contact of the lip on the shaft. It is the sum of the forces developed from seal interference and the garter spring.
LOP:	See Pressure, Lip Opening.
Lubricant, Mold:	The substance used to coat the surfaces of a mold to prevent the elastomer from adhering to the mold cavity surface during vulcanization.
Lubricant Starvation:	Lack of proper lubrication at the seal interface which may cause premature wear and early failure.

M

Machine Lead:	Spiral grooves similar to a screw thread on a shaft surface that can result from improper finishing process, may result in early leakage.
Modulus, Rubber:	The tensile stress at a specified elongation. A measure of resistance to deformation.
Modulus, Young's:	The ratio of the stress to the resulting strain (the latter expressed as a fraction of the original height or thickness in the direction of the force).
Mold Impression:	A molded imperfection on the surface of the seal.
Monomer:	A single organic molecule usually containing carbon and capable of additional polymerization.

N

Nib, Spring:	A short end section of an extension spring formed by a reduction in the coil diameter used to join the two ends in forming a garter spring.
Nick:	A void created in the seal material after molding.
Nitrile:	A general term for the copolymers of butadiene and acrylonitrile.
Nonfill:	A void in the seal material.
O	
Offset:	The radial distance between the axis of the seal bore and the axis of shaft rotation.
Oil Resistance:	The measure of an elastomer's ability to withstand the deteriorating effect of oil on the mechanical properties.

REFERENCE

Oil Seal:	A seal designed primarily for the retention of oil.
Oil Swell:	The change in volume of a rubber material due to absorption of oil.
O-Ring:	A torodial shaped seal.
Out-of-round, Shaft:	The deviation of the shaft cross section from a true circle. Out-of-round is measured as the radial distance, on a polar chart recording, between concentric, circumscribed, and inscribed circles which just contain the trace and are so centered that the radial distance is minimized.

P

Packing, Mechanical:	A deformable material used to prevent or control the passage of matter between surfaces which move in relation to each other.
Pitch, Helix Seal Rib:	The circumferential displacement between adjacent helical ribs of a lip seal.
Plasticity:	The degree or rate at which unvulcanized elastomer and elastomeric compounds will flow when subjected to forces of compression, shear or extrusion.
Plasticizer:	A material that when incorporated in elastomer or polymer, will change its hardness, flexibility, processability, and/or plasticity.
Plunge Ground:	The surface texture of shaft or wear sleeve produced by presenting the grinding wheel perpendicular to the rotating shaft without axial motion.
Polyacrylate:	A type of elastomer characterized by an unsaturated chain and being a copolymer of alkyl acrylate and some other monomer such as chloroethyl vinyl ether or vinyl chloroacetate.
Polymer:	Generic term for an organic compound of high molecular weight and consisting of recurrent structural groups.
Polymerization:	The ability of certain organic compounds to react together to form a single molecule of higher atomic weight.

REFERENCE

Polytetrafluoroethylene (PTFE):	PTFE is a fluoropolymer with excellent thermal and chemical resistance and low coefficient of friction. PTFE is usually compounded with fillers such as molybdenum disulfide, graphite, pigments, and glass fibers to improve wear characteristics and other properties.
Porosity:	A multitude of minute cavities in the seal material.
Position, Spring:	The axial distance between the seal contact line and the centerline of the spring groove of a radial lip seal, commonly referred to as the "R" value.
Precure-Partial Cure:	The first cure of a material that is given more than one cure in its manufacture.
Pressure-Partial Cure:	The first cure of a material that is given more than one cure is its manufacture.
Pressure, Contact:	The average pressure necessary for flowing air at 10.000 cm ³ /m between the contact surface of a radial lip seal and a shaft-size mandrel under the following conditions: the seal case outer diameter clamped to be concentric with the mandrel and the pressurized air applied to the outside lip surface.
Pressure, Seal Cavity:	The pressure of a fluid being sealed.
Pressure, Spring:	The contact pressure which results from the spring load.
PTFE Seal, Lay Down Lip:	Term used to describe a PTFE sealing element with a wide contact pattern on shaft. Often used with hydrodynamic features.
PTFE Seal, Line Contact Lip:	A seal utilizing an insert of PTFE bonded to an elastomeric back-up material. Shaft contact is over a narrow area similar to most radial lip seals.

R

Ra:	The average of all peaks and valleys from the mean line within cut-off (.10" or .254mm). Ra does not describe the surface profile (texture) and two shafts with the same Ra value can have very different surface characteristics.
-----	--

REFERENCE

Rate, Leakage:	The quantity of fluid passing through a seal is given length of time.
Rate, Spring:	The force, independent of initial tension, which is required for extending the working length of a spring a unit distance.
Rate, Wear:	The amount of seal contact surface wear per unit of time.
Relaxation, Stress:	A characteristics of an elastomer wherein a gradual increase in deformation is experienced under constant load, after the initial deformation.
Resilience:	In elastomer or rubber like materials subjected to and relieved of stress, resilience is the ratio of energy given up on recovery from the deformation to the energy required to produce the deformation. Resilience for an elastomer is usually expressed in percent.
Resistance, Cold:	The ability of a seal or sealing material to withstand the effects of a low temperature.
Resistance, Heat:	The ability of a seal or sealing material to resist the deteriorating effects of elevated temperatures.
Resistance, Ozone:	The ability of a material to withstand the deteriorating effects of ozone (surface cracking).
Rib:	A long, narrow projection which is normally triangular in cross-section and which is molded into the outside lip surface of a helix seal. It is oriented at an angle to the shaft axis. One end of the rib forms part of the seal-lip contact surface.
Rough Trim:	A trimmed surface with irregularities on the outside and inside lip surfaces in the immediate vicinity of the contact line.
Roughness:	Irregularities in shaft surface texture which result from the production process.
Roughness, Axial Surface:	Surface roughness of a shaft measured in a direction (plane) normal to the centerline axis.
Run-In:	The period of initial operation during which the seal-lip wear rate is greatest and the contact surface is developed.

REFERENCE

Runout, Dynamic: Twice the distance the center of the shaft is displaced from the center of rotation and expressed in TIR. That runout to which the seal lip is subjected due to the outside diameter of the shaft not rotating in a true circle.

RZ (din): Average peak to valley height.

S

Scoop Trim: A trimmed surface which is concave.

Scoring: A type of wear in which the working surface is grooved.

Scratch: A shallow discontinuity in the seal material whereby no material is removed.

Scuffing: Metal surface degradation resulting from adhesive wear.

Seal, Bonded: Design feature of a type of radial lip seal. The heel of the sealing element is attached (bonded) to the seal case by an adhesive during the molding operation.

Seal, Birotational: A rotary shaft seal which seal will seal fluid regardless of direction of shaft rotation.

Seal, Dynamic: A seal which has rotating, oscillation, or reciprocating motion between it and its mating surface, in contrast to stationary-type seals, such as a gasket.

Seal, Helix: An elastomeric hydrodynamic lip seal having helical ribs on the outside lip surface.

Seal, Hydrodynamic: A dynamic sealing device which utilizes the viscous shear and inertia forces of the fluid, imparted by a helically grooved O ribbed seal lip, to generate a pressure differential that opposes fluid flow.

Seal, Lip: An elastomeric seal which prevents leakage in dynamic and static applications by reason of controlled interference between the seal lip and the mating surface.

Seal, Mechanical: Any material or device that prevents or controls the passage of matter across the separable members of a mechanical assembly.

REFERENCE

Seal, Radial:	A seal which exerts radial sealing pressure in order to retain fluids and/or exclude foreign matter.
Seal, Radial Lip:	A type of seal which features a flexible sealing member referred to as a lip. The lip is usually of an elastomeric material. It exerts radial sealing pressure on a mating shaft in order to retain fluids and/or exclude foreign matter.
Seal, Shaft:	Generally considered to be a lip seal or an oil seal but a broad definition could include any sealing device mounted on a shaft or sealing a shaft.
Seal, Split:	A seal which has its primary sealing element split, approximately parallel with the shaft axial centerline. Typically used where conventional installation methods are impractical or impossible.
Seal, Unirotational:	A seal designed for applications having a single direction of shaft rotation.
Seal, Unitized:	A seal assembly in which all components necessary for accomplishing the complete sealing function are retained in a single package.
Sealer, Case OD:	A coating applied to the case OD to prevent leakage between the seal case and the housing bore.
Sealing Capacity:	The difference in leakage rates of a hydrodynamic seal and a nonhydrodynamic seal when tested on a shaft with a spiral groove that tends to pump oil out of the sump when the shaft is rotating.
Section, Flex:	The portion of a seal lip which is bounded by the head and heel section of a lip seal. Its primary function is to permit relative motion between the seal lip and the case.
Section, Head:	The portion of a lip seal which is generally defined by the inside and outside lip surface and the spring groove.
Section, Heel:	The portion of a lip seal which is attached to the seal case and bounded by the flex section and the outside face.

REFERENCE

Set, Compression:	The deformation which remains in rubber after it has been subject to and released from a specific percent compression for a definite period of time at a prescribed temperature. Compression set measurements are for the purpose of evaluating creep and stress relaxation properties of rubber.
Set, Permanent:	The residual unrecoverable deformation in an elastomeric part after the load causing the deformation has been removed.
Shaft Diameter:	The outside diameter of the shaft at the location where the seal is mounted.
Shaft Finish:	The relative roughness, usually expressed in micro inches, of the outside diameter of the shaft. The smaller the number, the smoother the finish.
Side, Air:	The side of a seal which in normal use faces away from the fluid being sealed.
Silicone:	A type of elastomer having a basic polymer of dimethyl polysiloxane, with various attached vinyl or phenyl groups.
Slant, Seal:	The difference between the maximum and minimum axial dimensions from the seal-lip contact line to the outside face of the case.
Sleeve, Wear:	A replaceable metal ring, generally used in assemblies to eliminate expensive shaft replacement caused by grooving that may occur at the seal-shaft interface.
Slinger:	A washer-like device used for imparting radial momentum to a liquid in order to keep the latter away from the sealing interface. Often incorporated into a wear sleeve.
Speed, Surface:	The linear velocity calculated from the shaft rotational speed using the nominal shaft diameter.
Spiral Trim:	A trimmed surface which has a spiral pattern.
Spring Axial Position:	The axial distance between the projected intersection of the inside and outside lip surface and centerline of the spring coil diameter (center plane of the spring) with the spring in position and the seal located on the shaft.

REFERENCE

Spring, Finger:	A spring consisting of a multiple number or cantilevered elements located circumferentially on a ring. It can be designed to produce either a radial or an axial force.
Spring, Garter:	A helically coiled wire with its ends connected to form a ring. It is used in tension for maintaining a radial sealing force between the sealing element of a radial lip seal and a shaft.
S.T.B.M:	Shaft to bore misalignment, the amount by which the shaft is off center, with respect to the bore's center.
Stability, Dimensional:	The ability to retain manufactured shape and size after having experienced the combination of operating stresses and temperatures.
Step Trim:	A trimmed surface having a discontinuity perpendicular to the contact line.
Stick, Slip:	A friction related phenomenon where the sealing element tends to adhere and rotate with the shaft surface momentarily until the elastic characteristics of the sealing element overcome the adhesive force, causing the seal lip to lose contact with the rotating shaft long enough to allow leakage. This cycle repeats itself continuously and is normally associated with non-lubricated/boundary lubricated conditions.
Sump Temperature:	The temperature of the fluid contained within the machinery sump.
Surface, Contact:	The portion of the seal lip which circumferentially contacts the shaft to form the seal-shaft interface.
Surface Contamination:	Foreign matter on the seal surface.
Surface, Inside Lip:	The inside truncated conical surface of the lip, the minor diameter of which terminates at the contact point.
Surface, Outside Lip:	The outside truncated conical surface of the lip, the minor diameter of which terminates at the contact point.
Surface Speed:	The linear velocity calculated from the shaft rotational speed, using the nominal shaft diameter.

REFERENCE

Surface, Trimmed Seal:	The lip surface formed by a knife cutting operation to develop the contact line.
Synthetic Rubber:	Synthetic elastomers made by polymerization of one or more monomers.

T

Tear:	The removal or separation of a portion of the sealing element.
Tear Resistance:	The property of an elastomeric material to resist tearing forces.
Tensile Strength, Ultimate:	The force per unit of original cross-sectional area at the moment of a specimen rupture.
Tension, Initial Spring:	The "preload" that has been wound into the coils of a spring during the coiling operation.
Test, Accelerated Life:	Any set of test conditions designed to reproduce in a short time the effects obtained under service conditions.
Test, Bench:	A laboratory test in which the functional operating conditions are approximated, but the equipment is conventional laboratory equipment and not necessarily identical with that in which the product will be used.
Test, Field:	A test performed in the actual environment in which the product will be used.
Test, Flex:	A laboratory method used to evaluate the resistance of a material to repeated bending.
Test, Life:	A laboratory procedure used to determine that period of operation which a component or assembly will operate until it no longer performs its intended function.
Texture, Shaft Surface:	A term used to describe the quality, appearance or characteristic of the shaft surface resulting from operations, such a grinding, polishing, burnishing and so on.
Thickness, Film:	In a dynamic seal, the distance separating the two surfaces which form the primary seal.
Trim:	The removal of the superfluous parts from a molded product, usually removal of parting line flash or feed sprues.

REFERENCE

Trim, Crooked:	See Slant, Seal.
Trim, Rough:	Irregularities on the outside and inside lip surfaces in the immediate vicinity of the contact line.

U

Unbonded Flash:	Flash which does not properly adhere to the mating material to which it is intended to be bonded.
Under Cure:	A degree of cure less than desired.
Underlip Temperature:	The temperature of the oil between the underlip and sump temperature.
Underlip Temperature Rise:	The difference between the underlip and sump temperature.
Unsprung Interference:	The difference between the shaft diameter and the unsprung lip diameter.

V

Value "R":	See position, Spring.
Variation, Contact Line Height:	The difference in the contact line height as measured at any two points on the contact line. Maximum contact line height variation is defined as seal slant.
Variation, Radial Wall:	The difference between the minimum and maximum radial wall dimensions when measured around 360 degrees of the lip seal.
Vibration, Torsional:	A vibration which has a circumferential angular direction. It is often generated by a stick-slip action between mating seal faces.
Volume Swell:	Increase in physical size caused by the swelling action of a liquid, generally expressed as a percent of the original volume.
Vulcanization:	An irreversible process during which a rubber compound, through a change in its chemical structure, becomes less plastic and more resistant to swelling by organic liquids and the elastic properties are confined, improved or extended over a greater range of temperature.

REFERENCE

W

Washer, Bonded:	A flat, metal, washer-type ring which has been molded in place in the elastomeric material forming one of the sealing elements.
Weepage:	A minute amount of liquid leakage by a seal.
Wetting:	A formation of a continuous film of a liquid on a surface.
Width, Case:	The total axial width of the seal case.
Width, Contact:	The width of the lip contact area of a radial lip seal, measured in the axial direction.
Width, Helix Contact:	The axial width of that portion of the contact surface of a helix seal which is formed by the helical ribs. It is equal to the total axial width of the contact surface minus the width of the static lip.
Width, Helix Seal Rib:	The maximum width of a helical rib measured perpendicular to the rib's longitudinal axis.
Width, Static Lip Contact:	The axial width of the contact surface developed by a static lip.
Wind-Up, Spring:	The tendency of a garter spring with ends assembled together to deform from a flat surface. Excessive spring wind-up results in the spring forming a figure "8" configuration.

FLUID COMPATIBILITY

Materials react in different ways depending on the fluid where they are immersed, the next table shows the compatibility of Nitrile, Polyacrylate, Silicon and Fluorocarbon with different fluids.

REFERENCE

CHEMICAL	SEALING MATERIAL			
	N	P	S	F
1-Butene, 2 Ethyl	1	--	4	1
1-Chloro-1-Nitro Ethane	4	4	4	4
51-F-23	1	1	3	1
Acetaldehyde	4	4	2	4
Acetamide	1	4	2	2
Acetic Acid, Glacial	3	4	2	3
Acetic Acid, 30%	2	4	1	2
Acetic Acid, 5%	2	--	1	1
Acetic Acid, hot high pressure	4	--	4	4
Acetic Anhydride	3	4	3	4
Acetone	4	4	3	4
Acetophenone	4	4	4	4
Acetyl Acetone	4	--	4	4
Acetyl Chloride	4	4	3	1
Acetylene	1	4	2	1
Acetylene Tetrabomide	4	--	--	1
Acrylonitrile	4	4	4	3
Adipic Acid	1	--	--	--
Aero Lubriplate	1	--	2	1
Aero Safe 2300	4	--	4	4
Aero Safe 2300W	4	--	4	4
Aero Shell 17 grease	1	--	2	1
Aero Shell 750	2	--	4	1
Aero Shell 7A grease	1	--	2	1
Aero Shell IAC	1	--	2	1
Aerozene 50 (50% Hydrazine, 50% UDMH)	4	--	4	4
Air above 300 F	4	--	1	1
Air below 300 F	2	--	1	1
Alkazene (Dibromoethylbenzene)	4	4	4	2
Alum-NH3-Cr_K (aq)	1	4	1	4
Aluminum Acetate (AQ)	2	4	4	4
Aluminum Bromide	1	--	1	1

REFERENCE

Lip Codes: N = Nitrile P = Polyacrylate S = Silicon F = Fluorocarbon

Ratings: 1 = Minor Affect 2 = Moderate Affect 3 = Static Only 4 = Not Recommended
 -- = Insufficient Data (AQ) = Aqueous

CHEMICAL	SEALING MATERIAL			
	N	P	S	F
Aluminum Chloride (AG)	1	1	2	1
Aluminum Fluoride (AQ)	1	--	2	1
Aluminum Nitrate (AQ)	1	--	2	1
Aluminum Phosphate (AQ)	1	--	1	1
Aluminum salts	1	--	1	1
Aluminum Sulfate(AQ)	1	4	1	1
Ambrex 33 mobile	1	--	4	1
Ammonia and Lithium in solution	2	--	4	4
Ammonia, Anhydrous	2	4	3	4
Ammonia gas (cold)	1	4	1	4
Ammonia gas (hot)	4	4	1	4
Ammonium Carbonate (AQ)	4	4	--	--
Ammonium Chloride (AQ)	1	--	--	1
Ammonium Hydroxide (conc.)	4	4	1	2
Ammonium Nitrate (AQ)	1	2	--	--
Ammonium Nitrite (AQ)	1	--	2	--
Ammonium Persulfate (AQ)	4	4	--	--
Ammonium Persulfate 10%	4	--	--	--
Ammonium Phosphate Dibasic Am- monium Phosphate	1	--	1	--
Monobasic	1	--	1	--
Ammonium Phosphate Tribasic	1	--	1	--
Ammonium Phosphate (AQ)	1	--	1	--
Ammonium salts	1	--	1	4
Ammonium Sulfate (AQ)	1	4	--	4
Ammonium Sulfide	1	--	--	4
Amyl Acetate (banana oil)	4	4	4	4
Amyl Alcohol	2	4	4	2
Amyl Borate	1	--	--	1
Amyl Chloride	--	--	4	1
Amyl Chloronaphthalene	4	4	4	1

REFERENCE

Lip Codes: N = Nitrile P = Polyacrylate S = Silicon F = Fluorocarbon

Ratings: 1 = Minor Affect 2 = Moderate Affect 3 = Static Only 4 = Not Recommended
 -- = Insufficient Data (AQ) = Aqueous

CHEMICAL	SEALING MATERIAL			
	N	P	S	F
Amyl Naphthalene	4	2	4	1
AN-O-3 Grade M	1	--	2	1
AN-O-366	1	--	4	1
AN-O-6	1	--	4	1
AN-W-O-366B Hydr. Fluid	1	--	4	1
Anderol L-774 (MIL-L-7808D)	2	4	1	1
Anderol L-826 (Diester)	2	--	4	1
Anderol L-829 (Diester)	2	--	4	1
ANG (Diester base) (TG749)	2	--	2	1
ANG (Glycerol Ester)	2	--	2	1
Anhydrous Ammonia	2	--	2	4
Anhydrous Hydrazine	4	--	--	4
Anhydrous Hydrogen Fluoride	4	--	--	4
Aniline	4	4	4	3
Aniline dyes	4	4	3	2
Aniline Hydrochloride	2	4	4	2
Aniline oils	4	--	4	4
Animal fats (butter)	1	1	2	1
Ansul Ether (Anesthetics)	3	4	4	4
API GL-5	2	1	4	1
Aqua Regia	4	4	4	2
Argon	4	--	2	1
Aroclor 1248	3	4	2	1
Aroclor 1254	4	4	3	1
Aroclor 1260	1	4	2	1
Aromatic fuel 50%	2	--	4	1
Arsenic Acid	1	3	1	1
Arsenic Trichloride (AQ)	1	--	--	--
Askrel	2	4	4	1
Asphalt	2	2	4	1
ASTM #1 Method D-471	1	1	3	1

REFERENCE

Lip Codes: N = Nitrile P = Polyacrylate S = Silicon F = Fluorocarbon

Ratings: 1 = Minor Affect 2 = Moderate Affect 3 = Static Only 4 = Not Recommended
 -- = Insufficient Data (AQ) = Aqueous

CHEMICAL	SEALING MATERIAL			
	N	P	S	F
ASTM #2 Method D-471	1	1	3	1
ASTM #3 Method D-471	1	1	3	1
ASTM #4 Method D-471	2	--	4	1
ASTM Reference Fuel A (MIL-S-3136B Type 1)	1	2	4	1
ASTM Reference Fuel B (MIL-S-3136B Type 3)	1	--	4	1
ASTM Reference Fuel C	2	4	4	1
ATF Type (Mercon)	1	1	1	1
ATF Type A	1	1	2	1
ATF Type F	1	1	2	1
ATF Type I	1	1	2	1
ATF Type II	1	1	2	1
ATL-857	2	--	4	1
Atlantic Dominion	1	--	4	1
Aurex 903R Mobile	1	--	4	1
Automotive brake fluid	4	--	4	4
B.P. Aero Hydraulic Fluid #1 (DTD585)	--	--	--	1
Banana oil (Amyl Acetate)	4	4	4	4
Bardol	4	--	4	1
Barium Chloride (AQ)	1	1	1	1
Barium Hydroxide (AQ)	1	4	1	1
Barium Sulfate (AQ)	1	4	1	1
Barium Sulfide (AQ)	1	4	1	1
Beer	1	4	1	1
Beer sugar liquors	1	4	1	1
Bel Ray SE 140	1	--	--	1
Bel Ray SE 290	2	--	--	4
Benzaldehyde	4	4	2	4
Benzene	4	4	4	2
Benzene sulfonic acid	4	4	4	1

REFERENCE

Lip Codes: N = Nitrile P = Polyacrylate S = Silicon F = Fluorocarbon

Ratings: 1 = Minor Affect 2 = Moderate Affect 3 = Static Only 4 = Not Recommended
 -- = Insufficient Data (AQ) = Aqueous

CHEMICAL	SEALING MATERIAL			
	N	P	S	F
Benzine (Ligroin) (Nitrobenzine)	1	1	4	1
Benzine (Pet Ether)	1	1	4	1
Benzoic acid	3	3	3	1
Benzophenone	--	--	--	1
Benzoyl Chloride	4	4	--	1
Benzyl Alcohol	4	4	2	1
Benzyl Benzoate	4	4	--	1
Benzyl Chloride	4	4	4	1
Biphenyl (Diphenyl) (Phenylbenzene)	4	4	4	1
Black Point 77	1	--	4	1
Black Sulphate liquors	2	--	2	1
Blast furnace gas	4	4	1	1
Bleach solutions	4	4	2	1
Borax	2	2	2	1
Bordeaux mixture	2	4	2	1
Boric Acid	1	4	1	1
Boron fluids (HEF)	2	--	4	1
Brake fluid (non-Petroleum)	4	--	4	4
Brake fluid (Wagner 21B)	3	--	3	4
Bray GG-130	2	--	4	1
Brayco 719-R (W-H-910)	4	--	2	4
Brayco 885 (MIL-L-6085A)	2	--	4	1
Brayco 910	2	--	4	4
Bret 710	2	--	4	4
Brine	1	4	1	1
BP, ISO 220 Mineral Oil, PM-220	1	1	2	1
Brom-113	4	--	4	--
Brom-114	2	--	4	2
Bromine	4	--	4	1
Bromine Trifluoride	4	4	4	4
Bromine Water	4	4	4	1

REFERENCE

Lip Codes: N = Nitrile P = Polyacrylate S = Silicon F = Fluorocarbon

Ratings: 1 = Minor Affect 2 = Moderate Affect 3 = Static Only 4 = Not Recommended
 -- = Insufficient Data (AQ) = Aqueous

CHEMICAL	SEALING MATERIAL			
	N	P	S	F
Bromine-Anhydrous	4	4	4	1
Bromine-Pentafluoride	4	--	4	4
Bromobenzene	4	4	4	1
Bromochloro Trifluoroethane	4	--	4	1
Bunker oil	1	1	2	1
Butadiene	4	4	4	1
Butane	1	1	4	1
Butane 2, 2-Dimethyl	1	--	4	1
Butane 2, 3-Dimethyl	1	--	4	1
Butanol (Butyl Alcohol)	1	--	2	1
Butter (animal fat)	1	1	2	1
Butyl Acetate	4	4	4	4
Butyl Acetyl Ricinoleate	3	--	--	1
Butyl Acrylate	4	4	--	4
Butyl Alcohol	1	4	2	1
Butyl Amine	3	4	4	4
Butyl Benzoate	4	4	--	1
Butyl Butyrate	4	--	--	1
Butyl Carbitol	4	4	4	1
Butyl Cellosolve	3	4	--	4
Butyl Cellosolve Adipate	4	--	2	2
Butyl Ether	4	--	4	4
Butyl Oleate	4	--	--	1
Butyl Stearate	2	--	--	1
Butylene	2	4	4	1
Butylaldehyde	4	4	4	4
Butyric Acid	4	--	--	2
Calcine liquors	1	--	--	1
Calcium Acetate (AQ)	2	4	4	4
Calcium Bisulfate (AQ)	4	4	1	1
Calcium Carbonate	1	--	1	1

REFERENCE

Lip Codes: N = Nitrile P = Polyacrylate S = Silicon F = Fluorocarbon

Ratings: 1 = Minor Affect 2 = Moderate Affect 3 = Static Only 4 = Not Recommended
 -- = Insufficient Data (AQ) = Aqueous

CHEMICAL	SEALING MATERIAL			
	N	P	S	F
Calcium Chloride (AQ)	1	1	1	1
Calcium Cyanide	1	--	1	--
Calcium Hydroxide (AQ)	1	4	1	1
Calcium Hypochloride	4	--	--	1
Calcium Hypochlorite (AQ)	2	4	2	1
Calcium Nitrate (AQ)	1	1	2	1
Calcium Phosphate	1	--	1	1
Calcium salts	1	--	--	1
Calcium Sulfide (AQ)	1	4	2	1
Calcium Sulfite	1	--	1	1
Calcium Thiosulphate	2	--	1	1
Caliche liquors	1	--	2	1
Cane sugar liquors	1	4	1	1
Caporic Aldehyde	--	--	2	4
Carbamate	3	4	--	1
Carbitol	2	4	2	2
Carbolic Acid (Phenol)	4	4	4	1
Carbon Bisulfide	3	3	4	1
Carbon Dioxide (wet or dry)	1	--	2	1
Carbon Disulfide	4	--	--	1
Carbon Monoxide	1	--	1	1
Carbon Tetrachloride	3	4	4	1
Carbonic Acid	2	--	1	1
Castor oil	1	1	1	1
Caustic soda	2	3	2	2
Cellosolve	4	4	4	3
Cellosolve Acetate	4	4	4	4
Cellosolve Butyl	4	--	4	4
Celluguard	1	--	1	1
Cellulube (Fryquel)	4	4	1	1
Cellulube 220 (see MIL-L-19457)	4	4	3	3

REFERENCE

Lip Codes: N = Nitrile P = Polyacrylate S = Silicon F = Fluorocarbon

Ratings: 1 = Minor Affect 2 = Moderate Affect 3 = Static Only 4 = Not Recommended
 -- = Insufficient Data (AQ) = Aqueous

CHEMICAL	SEALING MATERIAL			
	N	P	S	F
Cellulube 90, 100, 150, 220, 300, 500	4	--	1	1
Cellutherm 2505A	2	--	4	1
Cetane (Hexadecane)	1	--	4	1
China wood oil (Tung oil)	1	--	4	1
Chloracetic Acid	4	--	--	4
Chlorextol	2	--	4	1
Chlorinated salt Brine	4	--	4	1
Chlorinated solvents (wet or dry)	4	--	4	1
Chlorine (dry)	4	4	4	1
Chlorine (wet)	4	4	4	1
Chlorine Dioxide	4	4	--	1
Chlorine Trifluoride	4	4	4	4
Chloroacetic Acid	4	4	--	4
Chloroacetone	4	4	4	4
Chlorobenzene	4	4	4	1
Chlorobenzene (Mono)	4	--	4	1
Chlorobromomethane	4	4	4	1
Chlorobutadiene	4	4	4	1
Chlorodane	2	--	4	1
Chlorododecane	4	4	4	1
Chloroform	4	4	4	1
Chlorosulfonic Acid	4	4	4	4
Chlorotoluene	4	4	4	1
Chlorox (Sodium Hypochlorite NAOC1)	2	4	2	1
Chrom Alum	1	--	1	1
Chrome plating solutions	4	4	2	1
Chromic Acid	4	4	3	1
Chromic Oxide .88 Wt. % Aqueous Sol	4	--	2	1
Circo light processing oil	1	--	4	1
Citric Acid	1	--	1	1
City Service #'s 65, 120, 250	1	--	4	1

REFERENCE

Lip Codes: N = Nitrile P = Polyacrylate S = Silicon F = Fluorocarbon

Ratings: 1 = Minor Affect 2 = Moderate Affect 3 = Static Only 4 = Not Recommended
 -- = Insufficient Data (AQ) = Aqueous

CHEMICAL	SEALING MATERIAL			
	N	P	S	F
City Service Kool Motor-AP gear oil	1	--	4	1
City Service Pacemaker #2	1	--	4	1
CM Coolant #5	1	--	--	--
Coal Tar (Creosote)	1	1	4	1
Cobalt Chloride (2N)	1	--	1	1
Cobalt Chloride (AQ)	1	4	2	1
Coconut oil	1	1	1	1
Cod liver oil	1	1	2	1
Coffee (basically water)	1	--	--	1
Coke oven gas	4	4	2	1
Coliche liquors	2	--	--	--
Convelex 10	4	--	4	--
Coolanol (Monsanto)	1	--	4	1
Coolanol 45 (Monsanto)	1	--	4	1
Copper Acetate (AQ)	2	4	4	4
Copper Chloride (AQ)	1	1	1	1
Copper Cyanide (AQ)	1	1	1	1
Copper salts	1	--	1	1
Copper Sulfate (AQ)	1	4	1	1
Copper Sulfate 10%	1	--	1	1
Copper Sulfate 50%	1	--	1	1
Corn oil	1	1	1	1
Cottonseed oil	1	1	1	1
Creosote (coal tar)	1	1	4	1
Creosote (wood)	1	--	4	1
Cresol	4	4	4	1
Cresylic Acid	4	4	4	1
Crude oil	2	--	4	1
Cumene	4	4	4	1
Cutting oil	1	--	4	1
Cyclohexane	1	1	4	1

REFERENCE

Lip Codes: N = Nitrile P = Polyacrylate S = Silicon F = Fluorocarbon

Ratings: 1 = Minor Affect 2 = Moderate Affect 3 = Static Only 4 = Not Recommended
 -- = Insufficient Data (AQ) = Aqueous

CHEMICAL	SEALING MATERIAL			
	N	P	S	F
Cyclohexanol	3	--	4	1
Cyclohexanone	4	4	4	1
DC44M (Dow Corning)	3	3	3	1
DC44M hi temp Silicone grease	3	3	3	1
Decalin	4	--	4	1
Decane	1	1	2	1
Delco brake fluid	4	--	4	4
Denatured Alcohol	1	4	1	1
Detergent solutions	1	4	1	1
Developing fluids	1	--	1	1
Dextron	1	--	4	1
Di-Ester lubricant (MIL_L-7808)	2	--	4	1
Di-Ester synethic lubricant	2	--	4	1
Diacetone	4	4	4	4
Diacetone Alcohol	4	4	2	4
Diazion	4	--	4	2
Dibenzyl Ether	4	--	--	4
Dibenzyl Sebecate	4	4	3	2
Dibromoethylbenzene (Alkazene)	4	4	4	2
Dibutyl Amine	4	4	3	4
Dibutyl Ether	4	3	4	3
Dibutyl Phthalate	4	4	2	3
Dibutyl Sebecate	4	4	2	2
Dichloro-Butane	2	--	4	1
Dichloro-Isopropyl Ether	4	3	4	3
Dicyclohexylamine	3	4	--	4
Diesel fuel	1	1	4	1
Diethyl Benzene	4	--	4	1
Diethyl ether	4	3	4	4
Diethyl Sebecate	2	4	2	2
Diethylamine	2	4	2	4

REFERENCE

Lip Codes: N = Nitrile P = Polyacrylate S = Silicon F = Fluorocarbon

Ratings: 1 = Minor Affect 2 = Moderate Affect 3 = Static Only 4 = Not Recommended
 -- = Insufficient Data (AQ) = Aqueous

CHEMICAL	SEALING MATERIAL			
	N	P	S	F
Diethylene Glycol	1	2	2	1
Difluorodibromomethane	4	--	4	--
Diisobutylene	2	4	4	1
Diisooctyl Sebacate	4	--	4	2
Diisopropyl Benzene	4	--	--	1
Diisopropyl Ketone	4	4	4	4
Diisopropylidene Acetone (Phorone)	4	4	4	4
Dimethyl Aniline (Xylidine)	3	4	4	4
Dimethyl Disulfite (DMS)	4	4	4	4
Dimethyl Ether (Methyl Ether)	3	4	4	4
Dimethyl Ether (Monomethyl Ether)	1	4	1	1
Dimether Formamide	2	4	2	4
Dimethyl Phthalate	4	4	--	2
Dinitrotolene	4	4	4	4
Dioctyl Phthalate	3	4	3	2
Dioctyl Sebecate	4	4	3	2
Dioxane	4	4	4	4
Dioxolane	4	4	4	4
Dipentene	2	4	4	1
Diphenyl (Biphenyl) (Phenybenzene)	4	4	4	1
Diphenyl oxides	4	4	3	1
DMS (Dimethyl Disulfite)	4	4	4	4
Dow chemical 50-4	--	--	--	4
Dow chemical ET378	4	--	4	--
Dow chemical ET588	4	--	--	4
Dow Corning-11	1	--	4	1
Dow Corning-1208	1	--	4	1
Dow Corning-200	1	--	4	1
Dow Corning-220	1	--	4	1
Dow Corning-3	1	--	4	1
Dow Corning-33	1	--	4	1

REFERENCE

Lip Codes: N = Nitrile P = Polyacrylate S = Silicon F = Fluorocarbon

Ratings: 1 = Minor Affect 2 = Moderate Affect 3 = Static Only 4 = Not Recommended
 -- = Insufficient Data (AQ) = Aqueous

CHEMICAL	SEALING MATERIAL			
	N	P	S	F
Dow Corning-4	1	--	4	1
Dow Corning-4050	1	--	4	1
Dow Corning-44	1	--	4	1
Dow Corning-5	1	--	4	1
Dow Corning-510	1	--	4	1
Dow Corning-55	1	--	4	1
Dow Corning-550	1	--	4	1
Dow Corning-6620	1	--	4	1
Dow Corning-704	2	--	4	1
Dow Corning-705	2	--	--	1
Dow Corning-710	1	--	4	1
Dow Corning-F60	1	--	4	1
Dow Corning-F61	1	--	2	1
Dow Corning-XF61	1	--	4	1
Dow Guard	1	--	1	1
Dowtherm 209, 50% solution	4	--	4	4
Dowtherm A or E	4	--	4	1
Dowtherm oil	4	4	3	1
Drinking water (see note re. water)	1	--	1	1
Dry cleaning fluids	3	4	4	1
Elco 28-EP lubricant	1	--	4	1
Engine oil (Diester motor oil)	2	1	1	1
Engine oil (Hydrocarbon motor oil)	1	1	1	1
EP lubes	2	1	4	1
Epichlorohydrin	4	4	4	4
Epoxy resins	--	--	--	4
ESAM-6 fluid	--	--	--	4
Esso fuel 208	1	--	4	1
Esso golden gasoline	2	--	4	1
Esso GX 80W90 (GL-5)	2	1	4	1
Esso motor oil	1	--	4	1

REFERENCE

Lip Codes: N = Nitrile P = Polyacrylate S = Silicon F = Fluorocarbon

Ratings: 1 = Minor Affect 2 = Moderate Affect 3 = Static Only 4 = Not Recommended
 -- = Insufficient Data (AQ) = Aqueous

CHEMICAL	SEALING MATERIAL			
	N	P	S	F
Esso transmission fluid (Type A)	1	--	4	1
Esso WS3812 (MIL-L-7808)	1	--	4	1
Esso XP90 EP lubricant	1	--	4	1
Esstic 42,43	1	--	4	1
Esters	4	--	4	4
Ethane	1	--	4	1
Ethanol (Ethyl Alcohol)	1	4	1	3
Ethanolamine	2	4	2	4
Ethyl Acetate	4	4	2	4
Ethyl Acetate-organic Ester	4	--	2	4
Ethyl Acetoacetate	4	4	2	4
Ethyl Acrylate	4	4	2	4
Ethyl Acrylic Acid	4	--	4	--
Ethyl Alcohol (Ethanol)	1	4	1	3
Ethyl Benzene	4	4	4	1
Ethyl Benzoate	4	4	4	1
Ethyl Bromide	2	--	4	1
Ethyl Cellosolve	4	4	4	4
Ethyl Cellulose	2	4	3	4
Ethyl Chloride	1	4	4	1
Ethyl Chlorocarbonate	4	4	4	1
Ethyl Chloroformate	4	4	4	4
Ethyl Cyclopentane	1	--	4	1
Ethyl Ether	3	4	4	4
Ethyl Formate	4	--	--	1
Ethyl Hexanol	1	--	2	1
Ethyl Mercapton	4	--	3	2
Ethyl Oxalate	4	4	4	1
Ethyl Pentachlorobenzene	4	4	4	1
Ethyl Silicate	1	--	--	1
Ethylene	1	--	--	1

REFERENCE

Lip Codes: N = Nitrile P = Polyacrylate S = Silicon F = Fluorocarbon

Ratings: 1 = Minor Affect 2 = Moderate Affect 3 = Static Only 4 = Not Recommended
 -- = Insufficient Data (AQ) = Aqueous

CHEMICAL	SEALING MATERIAL			
	N	P	S	F
Ethylene Chloride	4	4	4	2
Ethylene Chlorohydrin	4	4	3	1
Ethylene Diamine	1	4	1	4
Ethylene Dibromide	4	--	4	1
Ethylene Dichloride	4	4	4	1
Ethylene Glycol	1	3	1	1
Ethylene Oxide	4	4	4	4
Ethylene Trichloride	4	4	4	1
Ethylmorpholene Stannus Octate 50/50	4	--	--	4
Fatty Acids	2	--	3	1
FC-43 Heptacosofluorotributylamine	1	--	1	1
FC75 Fluorocarbon	1	--	1	2
Ferric Chloride (AQ)	1	1	2	1
Ferric Nitrate (AQ)	1	1	3	1
Ferric Sulfate (AQ)	1	1	2	1
Fish oil	1	--	1	1
Fluorine (liquid)	4	4	4	2
Fluorobenzene	4	4	4	1
Fluoroboric Acid	1	--	--	--
Fluorolube	1	--	1	2
Formaldehyde (RT)	3	4	2	4
Formaldehyde, 37%	3	4	2	1
Formic Acid	2	--	--	3
Freon 11	2	--	--	1
Freon 112	3	--	4	1
Freon 113	1	--	4	2
Freon 114	1	--	4	2
Freon 114B2	2	--	4	2
Freon 115	1	--	--	2
Freon 12	1	1	4	2
Freon 12 and ASTM #2 oil (50/50)	1	--	4	1

REFERENCE

Lip Codes: N = Nitrile P = Polyacrylate S = Silicon F = Fluorocarbon

Ratings: 1 = Minor Affect 2 = Moderate Affect 3 = Static Only 4 = Not Recommended
 -- = Insufficient Data (AQ) = Aqueous

CHEMICAL	SEALING MATERIAL			
	N	P	S	F
Freon 12 and Suniso 4G (50/50)	1	--	4	1
Freon 13	1	--	4	1
Freon 134A	4	4	4	4
Freon 13B1	1	--	4	1
Freon 14	1	--	4	1
Freon 142B	1	--	--	4
Freon 152A	1	--	--	4
Freon 21	4	--	4	4
Freon 218	1	--	--	1
Freon 22	4	4	4	4
Freon 22 and ASTM #2 oil (50/50)	4	--	4	2
Freon 31	4	--	--	4
Freon 32	1	--	--	4
Freon 502	2	--	--	2
Freon BF	2	--	4	1
Freon C316	1	--	--	--
Freon C318	1	--	--	2
Freon MF	1	--	4	2
Freon PCA	1	--	4	2
Freon T-P35	1	--	1	1
Freon T-WD602	2	--	4	1
Freon TA	1	--	3	3
Freon TC	1	--	4	1
Freon TF	1	--	4	2
Freon TMC	2	--	3	1
Fuel oil	1	1	4	1
Fuel oil #6	2	--	4	1
Fuel oil, acidic	1	--	4	1
Fumaric Acid	1	4	2	1
Fuming Sulphuric Acid (20/25% Oleum)	4	--	4	1
Furan, Furfuran	4	4	--	--

REFERENCE

Lip Codes: N = Nitrile P = Polyacrylate S = Silicon F = Fluorocarbon

Ratings: 1 = Minor Affect 2 = Moderate Affect 3 = Static Only 4 = Not Recommended
 -- = Insufficient Data (AQ) = Aqueous

CHEMICAL	SEALING MATERIAL			
	N	P	S	F
Furaryl Alcohol	4	--	4	--
Furfural	4	4	4	4
Furfuraldehyde	4	--	4	4
Fyrquel (Cellulube)	4	--	1	1
Fyrquel 90, 100, 150, 220, 300, 500	4	--	1	1
Fyrquel A60	4	--	4	4
Gallic Acid	2	4	--	1
Gasohol (10% Ethanol or Methanol)	2	4	4	3
Gasoline (lead and no-lead)	2	4	4	1
Gelatin	1	4	1	1
Girling brake fluid	4	--	4	4
Glacial Acetic Acid	2	--	2	4
Glauber's salt (AQ)	4	4	--	1
Glucose	1	--	1	1
Glue	1	--	1	1
Glycerin	1	3	1	1
Grease	1	2	1	1
Green Sulfate liquor	2	2	1	1
Gulf endurance oils	1	--	4	1
Gulf FR fluids (emulsion)	1	--	4	1
Gulf FRG fluids	1	--	1	1
Gulf FRP fluids	4	--	1	2
Gulf harmony oils	1	--	4	1
Gulf high temperature grease	1	--	4	1
Gulf legion oils	1	--	4	1
Gulf paramount oils	1	--	4	1
Gulf security oils	1	--	4	1
Gulfcrown grease	1	--	4	1
Halothane	4	--	4	1
Halowax oil	4	--	4	1
Hannifin Lube A	1	--	2	1

REFERENCE

Lip Codes: N = Nitrile P = Polyacrylate S = Silicon F = Fluorocarbon

Ratings: 1 = Minor Affect 2 = Moderate Affect 3 = Static Only 4 = Not Recommended
 -- = Insufficient Data (AQ) = Aqueous

CHEMICAL	SEALING MATERIAL			
	N	P	S	F
Heavy water (Deuterium)	1	--	1	1
Hef (high energy fuel)	2	--	4	1
Helium	1	1	1	1
Hexane	1	1	4	1
Hexyl alcohol	1	4	2	1
High viscosity lubricant, H2	1	--	1	1
High viscosity lubricant, U4	1	--	1	1
Hilo MS #1	4	--	4	4
Houghto-Safe 1010, Phosphate Ester	4	--	4	1
Houghto-Safe 1055, Phosphate Ester	4	--	4	1
Houghto-Safe 1120, Phosphate Ester	4	--	4	1
Houghto-Safe 271 H2O and Glycol base	1	--	2	2
Houghto-Safe 5040, water/oil emulsion	1	--	4	1
Houghto-Safe 620 water/glycol	1	--	2	2
Hydraulic oil (Petroleum)	1	1	3	1
Hydrazine	2	--	3	4
Hydro-Driv, MIH-10 (Petroleum base)	1	--	2	1
Hydro-Driv, MIH-50 (Petroleum base)	1	--	2	1
Hydrobromic Acid	4	4	4	1
Hydrobromic Acid 40%	4	4	4	1
Hydrocarbons (saturated)	1	--	4	1
Hydrochloric Acid (cold) 37%	3	4	3	1
Hydrochloric Acid (hot) 37%	4	4	4	2
Hydrochloric Acid 3 molar	4	--	4	1
Hydrocyanic Acid	2	4	3	1
Hydrofluoric Acid (conc.) cold	4	4	4	1
Hydrofluoric Acid (conc.) hot	4	4	4	3
Hydrofluoric Acid, Anhydrous	4	4	4	4
Hydrofluorsilicic	1	--	4	1
(Fluosilicic) Acid	1	--	4	1
Hydrogen gas	1	2	3	1

REFERENCE

Lip Codes: N = Nitrile P = Polyacrylate S = Silicon F = Fluorocarbon

Ratings: 1 = Minor Affect 2 = Moderate Affect 3 = Static Only 4 = Not Recommended
 -- = Insufficient Data (AQ) = Aqueous

CHEMICAL	SEALING MATERIAL			
	N	P	S	F
Hydrogen Peroxide (90%)	4	4	2	2
Hydrogen Sulfide (wet) cold	4	4	3	4
Hydrogen Sulfide (wet) hot	4	4	3	4
Hydrolube-water/Ethylene Glycol	1	--	2	1
Hydroquinone	3	4	--	2
Hydyne	2	--	4	4
Hyjet	4	--	--	4
Hyjet III	4	--	--	4
Hyjet S	4	--	--	4
Hyjet W	4	--	--	4
Hypochlorous Acid	4	4	--	1
Isopropyl Acetate	4	4	4	4
Industron FF44	1	--	4	1
Industron FF48	1	--	4	1
Industron FF53	1	--	4	1
Industron FF80	1	--	4	1
Iodine	2	--	--	1
Iodine Pentafluoride	4	4	4	4
ISO-Butyl N-Butyrate	4	--	--	1
Isobutyl Alcohol	2	4	1	1
Isododecane	1	--	4	1
Isooctane	1	1	4	1
Isophorone	4	4	4	4
Isopropanol	2	--	1	1
Isopropyl Acetate	4	4	4	4
Isopropyl Alcohol	2	4	1	1
Isopropyl Chloride	4	4	4	1
Isopropyl Ether	2	3	4	4
JP3, JP4, JP5 (see MIL-J-5624G)	1	2	4	1
JP6 (see MIL-F-25656B)	1	--	4	1
JPX (see MIL-F-25604)	1	--	4	4

REFERENCE

Lip Codes: N = Nitrile P = Polyacrylate S = Silicon F = Fluorocarbon

Ratings: 1 = Minor Affect 2 = Moderate Affect 3 = Static Only 4 = Not Recommended
 -- = Insufficient Data (AQ) = Aqueous

CHEMICAL	SEALING MATERIAL			
	N	P	S	F
KEL-F liquids	1	--	1	2
Kerosene	1	1	4	1
Keystone #87 HX-grease	1	--	4	1
Keystone (KSL) Diester lube	2	--	--	1
Krytox, LVP (Dupont)	1	1	1	1
Lacquer solvents	4	4	4	4
Lacquers	4	4	4	4
Lactams-Amino Acids	4	--	--	4
Lacquer solvents	4	4	4	4
Lactic Acid (cold)	1	4	1	1
Lactic Acid (hot)	4	4	2	1
Lard	1	1	2	1
Lavender oil	2	2	4	1
Lead Acetate (AQ)	2	4	4	4
Lead Nitrate (AQ)	1	--	2	--
Lead Sulfamate (AQ)	2	4	2	1
Legroin (Benzine)	1	1	4	1
Legroin (Nitrobenzine)	1	1	4	1
Legroin (Pet Ether)	1	1	4	1
Lehigh X1169	1	--	4	1
Lehigh X1170	1	--	4	1
Light grease	1	--	4	1
Lime bleach	1	4	2	1
Lime Sulfur	4	4	4	1
Lime water (Calcium Hydroxide-AQ)	1	4	1	1
Lindol (Hydraulic fluid)	4	4	2	2
Linoleic Acid	2	--	1	2
Linseed oil	1	1	--	1
Liquefied Petroleum gas	1	3	1	1
Liquid Oxygen	4	--	4	4
Lubricating oils (Di-Ester)	1	--	4	1

REFERENCE

Lip Codes: N = Nitrile P = Polyacrylate S = Silicon F = Fluorocarbon

Ratings: 1 = Minor Affect 2 = Moderate Affect 3 = Static Only 4 = Not Recommended
 -- = Insufficient Data (AQ) = Aqueous

CHEMICAL	SEALING MATERIAL			
	N	P	S	F
Lubricating oils (Petroleum)	1	1	4	1
Lye	2	3	2	2
Magnesium Chloride (AQ)	1	--	1	1
Magnesium Hydroxide (AQ)	2	4	--	1
Magnesium salts	1	--	1	1
Magnesium sulfate (AQ)	1	4	1	1
Magnesium Sulfite	1	--	1	1
Malathion	2	--	4	1
Maleic Acid	4	4	--	1
Maleic Anhydride	4	4	--	4
Malic Acid	1	4	2	1
MCS 312	4	--	1	1
MCS 352,463	4	--	4	1
MEK (Methyl Ethyl Ketone)	4	4	4	4
Mercury	1	--	--	1
Mercury Chloride (AQ)	1	--	--	1
Mercury vapors	1	--	--	1
Mesityl oxide	4	4	4	4
Methane	1	1	4	2
Methane, Sulfurated (odor detection)	1	1	4	2
Menthanol (Methyl Alcohol)	1	4	1	4
Methyl Acetate	4	4	4	4
Methyl Acetoacetate	4	--	2	4
Methyl Acetone	4	4	3	4
Methyl Acrylate	4	4	4	4
Methyl Alcohol (Ethanol)	1	4	1	4
Methyl Benzoate	4	--	4	1
Methyl Bromide	2	3	--	1
Methyl Butyl Ketone (Propyl Acetone)	4	4	3	4
Methyl Carbonate	4	--	4	1
Methyl Cellosolve	3	4	4	4

REFERENCE

Lip Codes: N = Nitrile P = Polyacrylate S = Silicon F = Fluorocarbon

Ratings: 1 = Minor Affect 2 = Moderate Affect 3 = Static Only 4 = Not Recommended
 -- = Insufficient Data (AQ) = Aqueous

CHEMICAL	SEALING MATERIAL			
	N	P	S	F
Methyl Cellulose	2	--	2	4
Methyl Chloride	4	4	4	2
Methyl Chloroformate	4	--	4	1
Methyl Cyclopentane	4	4	4	2
Methyl D-Bromide	4	--	4	1
Methyl Ether (Dimethyl Ether)	1	4	1	1
Methyl Ether (Monomethyl Ether)	1	4	1	1
Methyl Ethyl Ketone (MEK)	4	4	4	4
Methyl Ethyl Ketone Peroxide	4	--	2	4
Methyl Formate	4	--	--	--
Methyl Isobutyl Ketone	4	4	4	4
Methyl Methacrylate	4	4	4	4
Methyl Oleate	4	--	--	2
Methyl Salicylate	4	--	--	--
Methylacrylic Acid	4	4	4	4
Methylene Chloride	4	4	4	2
Methylene Dichloride	4	--	4	2
MIL-1-8660 B	1	--	4	1
MIL-A-6091	2	--	1	1
MIL-A-8243 B	1	3	2	2
MIL-C-4339 C	1	1	3	1
MIL-C-5545 A	2	2	4	1
MIL-C-6529 C	2	2	4	1
Mil-C-8188 C	1	3	3	1
MIL-E-9500	1	--	1	1
MIL-F-16884	1	--	4	1
MIL-F-16929 A	1	3	3	1
MIL-F-17111	1	1	3	1
MIL-F-19605	1	--	4	1
MIL-F-25172	1	--	4	1
MIL-F-25524 A	1	--	4	1

REFERENCE

Lip Codes: N = Nitrile P = Polyacrylate S = Silicon F = Fluorocarbon

Ratings: 1 = Minor Affect 2 = Moderate Affect 3 = Static Only 4 = Not Recommended
 -- = Insufficient Data (AQ) = Aqueous

CHEMICAL	SEALING MATERIAL			
	N	P	S	F
MIL-F-25558 B (RJ-1)	1	1	3	1
MIL-F-25576 C (RP-1)	1	1	4	1
MIL-F-25656 B	1	--	4	1
MIL-F-5566	1	--	1	1
MIL-F-5602	1	1	3	1
MIL-F-7024 A	1	2	4	1
MIL-G-10924	1	1	4	1
MIL-G-10924 B	1	1	3	1
MIL-G-15793	1	3	3	1
MIL-G-18709 A	1	1	3	1
MIL-G-2108	1	1	3	1
MIL-G-23827 A	1	3	3	1
MIL-G-25013 D	1	2	4	1
MIL-G-25537 A	1	1	3	1
MIL-G-25760 A	1	3	4	1
MIL-G-27343	1	--	4	1
MIL-G-27617	4	--	4	1
MIL-G-3278	2	--	4	1
MIL-G-4343 B	2	1	4	1
MIL-G-7118 A	1	3	3	1
MIL-G-7187	1	1	3	1
MIL-G-7421 A	1	--	3	1
MIL-G-7711 A	1	1	3	1
MIL-G-81322	2	--	--	--
MIL-H-13862	1	1	3	1
MIL-H-13866 A	1	1	3	1
MIL-H-13910 B	2	2	4	1
MIL-H-13919 A	1	1	3	1
MIL-H-19457 B	4	4	3	3
MIL-H-22072	1	3	2	2
MIL-H-22251	2	--	4	--

REFERENCE

Lip Codes: N = Nitrile P = Polyacrylate S = Silicon F = Fluorocarbon

Ratings: 1 = Minor Affect 2 = Moderate Affect 3 = Static Only 4 = Not Recommended
 -- = Insufficient Data (AQ) = Aqueous

CHEMICAL	SEALING MATERIAL			
	N	P	S	F
MIL-H-25598	1	1	3	1
MIL-H-27601 A	2	2	4	1
MIL-H-46001 A	1	1	3	1
MIL-H-46004	1	1	3	1
MIL-H-5559 A	1	3	2	2
MIL-H-5606 B red oil	1	1	4	1
MIL-H-6083 C	1	1	3	1
MIL-H-7083 A	1	3	2	2
MIL-H-7644	2	2	4	1
MIL-H-81019 B	1	1	3	1
MIL-H-8446 B (MLO-8515)	2	3	4	1
MIL-I-27686 D	1	3	2	2
MIL-J-5161 F	1	--	4	1
MIL-J-5624 G JP-3, JP-4, JP-5	1	2	4	1
MIL-L-10295 A	1	1	3	1
MIL-L-10324 A	1	1	3	1
MIL-L-11734 B	1	3	3	1
MIL-L-14107 B	3	--	4	1
MIL-L-15016	1	--	4	1
MIL-L-15017	1	1	3	1
MIL-L-15018 B	1	1	3	1
MIL-L-15019 C	1	1	3	1
MIL-L-15719 A	2	2	4	1
MIL-L-16958 A	1	1	3	1
MIL-L-17331 D	1	1	3	1
MIL-L-17353 A	1	--	3	1
MIL-L-17672 B	1	1	3	1
MIL-L-18486 A	1	1	3	1
MIL-L-19457	4	4	3	3
MIL-L-19701	1	3	3	1
MIL-L-2104 B	1	1	3	1

REFERENCE

Lip Codes: N = Nitrile P = Polyacrylate S = Silicon F = Fluorocarbon

Ratings: 1 = Minor Affect 2 = Moderate Affect 3 = Static Only 4 = Not Recommended
 -- = Insufficient Data (AQ) = Aqueous

CHEMICAL	SEALING MATERIAL			
	N	P	S	F
MIL-L-2105 B	1	1	3	1
MIL-L-2105 C (API GL-5)	2	1	4	1
MIL-L-21260	1	1	3	1
MIL-L-22396	1	1	3	1
MIL-L-23699 A	1	3	3	1
MIL-L-25336 B	1	3	3	1
MIL-L-25681 C	1	2	4	1
MIL-L-25968	1	3	3	1
MIL-L-26087 A	1	1	3	1
MIL-L-27694 A	1	--	4	1
MIL-L-3150 A	1	1	3	1
MIL-L-3503	1	1	3	1
MIL-L-3545 B	2	2	4	1
MIL-L-46000 A	1	3	3	1
MIL-L-46002	1	--	3	1
MIL-L-5020 A	1	2	4	1
MIL-L-5606	1	1	4	1
MIL-L-6082 A	1	1	1	1
MIL-L-6082 C	1	1	3	1
MIL-L-6085 A	1	3	3	1
MIL-L-6086 B	1	1	3	1
MIL-L-6387 A	1	--	3	1
MIL-L-644 B	1	2	3	--
MIL-L-7645	2	2	4	1
MIL-L-7808 D	2	4	1	1
MIL-L-7808 E	2	4	1	2
MIL-L-7808 F	2	3	1	1
MIL-L-7870 A	1	1	3	1
MIL-L-8383 B	1	1	3	1
MIL-L-9000 F	1	2	4	1
MIL-L-9236 B	1	3	4	1

REFERENCE

Lip Codes: N = Nitrile P = Polyacrylate S = Silicon F = Fluorocarbon

Ratings: 1 = Minor Affect 2 = Moderate Affect 3 = Static Only 4 = Not Recommended
 -- = Insufficient Data (AQ) = Aqueous

CHEMICAL	SEALING MATERIAL			
	N	P	S	F
MIL-O-11773	1	3	3	1
MIL-O-6081 C	1	1	3	1
MIL-P-12098	2	2	4	1
MIL-P-46046 A	2	2	4	1
MIL-S-21568 A	1	1	4	1
MIL-S-3136 B Type I	1	2	4	1
MIL-S-3136 B Type II	1	--	4	1
MIL-S-3136 B Type III	1	--	4	1
MIL-S-3136 B Type IV	1	1	3	1
MIL-S-3136 Type V	1	1	3	1
MIL-S-3136 B Type VI	1	1	3	1
MIL-S-3136 B Type VII	1	--	4	1
MIL-S-81087	1	--	4	1
MIL-T-9188 B	4	4	4	4
Milk	1	4	1	1
Mineral oil	1	1	2	1
Mineral spirits	2	--	4	1
Mobil SHC 525	1	4	4	3
Mobil SHC 624	2	4	4	3
Mobil SHC 626	2	4	4	3
Mobil SHC 629	2	3	4	2
Mobil SHC 630	2	2	4	1
Mobil SHC 632	2	1	4	1
Mobil SHC 634	1	1	4	1
Mobil SHC 75W90	1	3	4	2
Mono Ethanolamine	4	--	2	4
Monobromobenzene	4	--	4	1
Monochlorobenzene	4	4	4	1
Monoethanol Amine	4	4	2	4
Monomethyl Aniline	4	4	--	2
Monomethyl Ether (Dimethyl Ether)	1	4	1	1

REFERENCE

Lip Codes: N = Nitrile P = Polyacrylate S = Silicon F = Fluorocarbon

Ratings: 1 = Minor Affect 2 = Moderate Affect 3 = Static Only 4 = Not Recommended
 -- = Insufficient Data (AQ) = Aqueous

CHEMICAL	SEALING MATERIAL			
	N	P	S	F
Monomethyl Ether (Methyl Ether)	1	4	1	1
Monomethyl Hydrazine	2	--	4	--
Mononitrotoluene/Dinitrotoluene 40/60	4	--	4	4
Monovinyl Acetylene	1	--	2	1
Mopar brake fluid	4	--	4	4
Mustard gas	--	--	1	--
Myvacet 9-45	1	--	--	1
N-Heptane	1	--	4	1
N-Hexaldehyde	4	--	2	4
N-Hexene-1	2	1	4	1
N-Octane	2	4	4	1
N-Pentane	1	--	4	1
N-Propyl Acetate	4	4	4	4
Naptha	2	2	4	1
Naphthaienic Acid	2	--	4	1
Naphthalene	4	--	4	1
Natural gas	1	2	1	1
Neat's foot oil	1	1	2	1
Neon	1	--	1	1
Neville Acid	4	4	4	1
Nickel Acetate (AQ)	2	4	4	4
Nickel Chloride (AQ)	1	3	1	1
Nickel salts	1	--	1	1
Nickel Sulfate (AQ)	1	4	1	1
Niter cake	1	4	1	1
Nitric Acid (conc.)	4	4	4	3
Nitric Acid (dilute)	4	4	2	1
Nitric Acid, red fuming	4	4	4	4
Nitrobenzene	4	4	4	2
Nitrobenzene (Petroleum Ether)	1	1	4	1
Nitrobenzine	--	--	--	1

REFERENCE

Lip Codes: N = Nitrile P = Polyacrylate S = Silicon F = Fluorocarbon

Ratings: 1 = Minor Affect 2 = Moderate Affect 3 = Static Only 4 = Not Recommended
 -- = Insufficient Data (AQ) = Aqueous

CHEMICAL	SEALING MATERIAL			
	N	P	S	F
Nitroethane	4	4	4	4
Nitrogen	1	1	1	1
Nitrogen Tetroxide	4	4	4	4
Nitromethane	4	4	4	4
Nitropropane	4	--	4	4
No. 5 cm coolant	1	--	--	--
O-A-548A	1	3	2	2
O-Chloronaphthalene	4	4	4	1
O-Chlorophenol	4	--	4	1
O-Dichlorobenzene	4	4	4	1
O-Dichorobenzene	4	4	4	1
O-T-634B	3	4	4	1
Octachlorotoluene	4	4	4	1
Octadecane	1	2	4	1
Octyl Alcohol	2	4	2	1
Oleic Acid	3	4	4	2
Oleum (Fuming Sulfuric Acid)	4	--	4	1
Oleum spirits	2	--	4	1
Olive oil	1	1	3	1
Oronite 8200 (see MIL-H-8446B)	2	3	4	1
Orthochloro Ethyl Benzene	4	--	4	1
OS 45 Type III (OS45)	2	--	4	1
OS 45 Type IV (OS45-1)	2	--	4	1
OS 70	2	--	4	1
Oxalic Acid	2	--	2	1
Oxygen-(200-400 degrees F.)	4	4	2	2
Oxygen, cold	2	2	1	1
Ozone	4	2	1	1
P-Cymene	4	4	4	1
P-D-680	1	--	4	1
P-D-680B	1	--	4	1

REFERENCE

Lip Codes: N = Nitrile P = Polyacrylate S = Silicon F = Fluorocarbon

Ratings: 1 = Minor Affect 2 = Moderate Affect 3 = Static Only 4 = Not Recommended
 -- = Insufficient Data (AQ) = Aqueous

CHEMICAL	SEALING MATERIAL			
	N	P	S	F
P-Dichlorobenzene	4	--	4	1
P-S-661B	1	--	4	1
Paint thinner, Duco	4	4	4	2
Palmitic Acid	1	--	4	1
Par-Al-Ketone	4	--	4	4
Para-Dichlorobenzene	4	--	4	1
Parker O-Lube	1	--	1	1
Peanut oil	1	1	1	1
Pentane, 2 Methyl	1	--	4	1
Pentane, 2-4 Dimethyl	1	--	4	1
Pentane, 3 Methyl	1	--	4	1
Perchloric Acid	4	4	4	1
Perchloroethylene	2	4	4	1
Petroleum, above 250 degrees F.	4	4	4	2
Petroleum, below 250 degrees F.	1	2	2	1
Phenol (Carbolic Acid)	4	4	4	1
Phenol, 70%/30% water	4	--	4	1
Phenol, 85%/15% water	4	--	4	1
Phenylbenzene	4	4	4	1
Phenyl Ethyl Ether	4	4	4	4
Phenyl Hydrazine	4	4	--	1
Phenylbenzene	4	4	4	1
Phorone (Disopropylidene Acetone)	4	4	4	4
Phosphate Ester	4	4	1	1
Phosphoric Acid, 20%	2	--	2	1
Phosphoric Acid-3 molar	4	--	2	1
Phosphoric Acid-45%	4	--	3	1
Phosphoric Acid, concentrated	4	--	2	1
Phosphorus Trichloride	4	--	--	1
Pickling solution	4	4	4	2
Picric Acid	2	--	4	1

REFERENCE

Lip Codes: N = Nitrile P = Polyacrylate S = Silicon F = Fluorocarbon

Ratings: 1 = Minor Affect 2 = Moderate Affect 3 = Static Only 4 = Not Recommended
 -- = Insufficient Data (AQ) = Aqueous

CHEMICAL	SEALING MATERIAL			
	N	P	S	F
Pine oil	4	--	4	1
Pinene	2	4	4	1
Piperidine	4	4	4	4
Plating solution, chrome	--	--	4	1
Plating solution, others	1	--	4	1
Polyalkylene Glycol (Ucon-51 lube)	--	--	2	2
Potassium Acetate (AQ)	2	4	4	4
Potassium Chloride (AQ)	1	1	1	1
Potassium Cupro Cyanide (AQ)	1	1	1	1
Potassium Cyanide (AQ)	1	1	1	1
Potassium Dichromate (AQ)	1	1	1	1
Potassium Hydroxide (AQ)	2	4	3	4
Potassium Nitrate (AQ)	1	1	1	1
Potassium salts	1	--	1	1
Potassium Sulfate (AQ)	1	4	1	1
Potassium Sulfite	1	--	1	1
Prestone anti-freeze	1	--	1	1
PRL-high temp Hydr oil	2	--	2	1
Producer gas	1	2	2	1
Propane	1	1	4	1
Propane Propionitrile	1	--	4	1
Propyl Acetone (Methyl Butyl Ketone)	4	4	3	4
Propyl Alcohol	1	4	1	1
Propyl Nitrate	4	4	4	4
Propylene	4	4	4	1
Propylene Oxide	4	4	4	4
Pydraul, 10E, 29 ELT	4	4	4	1
Pydraul, 115E	4	4	4	1
Pydraul, 230E, 312C, 540C	4	4	4	1
Pydraul, 30E, 50E, 65E, 90E	4	4	1	1
Pyranol	1	--	4	1

REFERENCE

Lip Codes: N = Nitrile P = Polyacrylate S = Silicon F = Fluorocarbon

Ratings: 1 = Minor Affect 2 = Moderate Affect 3 = Static Only 4 = Not Recommended
 -- = Insufficient Data (AQ) = Aqueous

CHEMICAL	SEALING MATERIAL			
	N	P	S	F
Pyranol, transformer oil	1	1	4	1
Pyridine	4	4	4	4
Pyrogard, 42, 43, 53, 55 (Phosphate Ester)	4	--	4	1
Pyrogard C, D	1	--	2	1
Pyroligenous Acid	4	4	--	4
Pyrolube	4	--	2	1
Pyrrrole	4	4	2	4
Quaker 613-AS	2	3	2	2
Radiation	3	3	3	4
Rapeseed oil	2	2	4	1
Red Line 100 oil	1	--	4	1
Red oil (MIL-H-5606)	1	1	4	1
RJ-1 (MIL-F-25558B)	1	1	4	1
RP-1 (MIL-F-25576C)	1	1	4	1
SAE 30	1	1	1	1
SAE 90	1	1	4	1
SAE 90 EP (GL-5)	2	1	4	1
Sal Ammoniac	1	1	2	1
Salicylic Acid	2	--	--	1
Salt water	1	4	1	1
Santo Safe 300	4	--	1	1
Sewage	1	4	2	1
Shell Alvania grease #2	1	--	2	1
Shell Carnea 19 and 29	1	--	--	1
Shell Diala	1	--	--	1
Shell Iris 3XF mine fluid (fire rest)	1	--	--	1
Shell Iris 905	1	--	--	1
Shell Iris Tellus #27, pet base	1	--	4	1
Shell Iris Tellus #33	1	--	4	1
Shell Iris UMF (5% aromatic)	1	--	4	1

REFERENCE

Lip Codes: N = Nitrile P = Polyacrylate S = Silicon F = Fluorocarbon

Ratings: 1 = Minor Affect 2 = Moderate Affect 3 = Static Only 4 = Not Recommended
 -- = Insufficient Data (AQ) = Aqueous

CHEMICAL	SEALING MATERIAL			
	N	P	S	F
Shell lo Hydrax 27 and 29	1	--	4	1
Shell macoma 72	1	--	4	1
Silicate Esters	2	--	4	1
Silicone greases	1	1	3	1
Silicone oils	1	1	3	1
Silver Nitrate	2	1	1	1
Sinclair Opaline CX-EP lube	1	--	4	1
Skelly solvent B, C, E	1	--	--	1
Skydrol 500	4	4	3	4
Skydrol 7000	4	4	3	2
Soap solutions	1	4	1	1
Socony Mobil Type A	1	--	4	1
Socony vacuum AMV AC781 (grease)	1	--	4	1
Socony vacuum PD959B	4	--	4	1
Soda ash	1	--	1	1
Sodium Acetate (AQ)	2	4	4	4
Sodium Bicarbonate (AQ) baking soda	1	--	1	1
Sodium Bisulfite (AQ)	1	4	1	1
Sodium Borate (AQ)	1	--	1	1
Sodium Carbonate (soda ash)	1	--	1	1
Sodium Chloride (AQ)	1	--	1	1
Sodium Cyanide (AQ)	1	--	1	1
Sodium Hydroxide (AQ)	2	3	2	2
Sodium Hypochlorite (AQ) (Chlorax)	2	4	2	1
Sodium Metaphosphate (AQ)	1	--	--	1
Sodium Nitrate (AQ)	2	--	4	--
Sodium Perborate (AQ)	2	--	2	1
Sodium Peroxide (AQ)	2	4	4	1
Sodium Phosphate (AQ)	1	1	4	1
Sodium salts	1	--	1	1
Sodium Silicate (AQ)	1	--	--	1

REFERENCE

Lip Codes: N = Nitrile P = Polyacrylate S = Silicon F = Fluorocarbon

Ratings: 1 = Minor Affect 2 = Moderate Affect 3 = Static Only 4 = Not Recommended
 -- = Insufficient Data (AQ) = Aqueous

CHEMICAL	SEALING MATERIAL			
	N	P	S	F
Sodium Sulfate (AQ)	1	4	1	1
Sodium Sulfite	1	--	1	1
Sodium Sulphide	1	--	1	1
Sodium Thiosulfate (AQ)	2	4	1	1
Sovasol #1, 2, 3	1	--	4	1
Sovasol #73, 74	2	--	4	1
Soybean oil	1	1	1	1
SPRY	1	--	1	1
SR-10 Fuel	1	--	4	1
SR-6 Fuel	2	--	4	1
Stannic Chloride (AQ)	1	--	2	1
Stannous Chloride (AQ)	1	--	2	1
Stauffer 7700	2	--	4	1
Steam over 300 degrees F. (water)	4	4	4	4
Steam under 300 degrees F. (water)	4	4	3	4
Stearic acid	2	--	2	--
Stoddard solvent	1	1	4	1
Styrene	4	4	4	2
Sucrose solution	1	4	1	1
Sulfite liquors	2	4	4	1
Sulfur	4	4	3	1
Sulfur Chloride (AQ)	3	4	3	1
Sulfur Dioxide (dry)	4	4	2	1
Sulfur Dioxide (wet)	4	4	2	1
Sulfur Dioxide liquid (under pressure)	4	4	2	1
Sulfur Hexafluoride	2	4	2	1
Sulfur liquors	2	--	4	1
Sulfur Trioxide	4	4	2	1
Sulfur-Molten	4	--	4	1
Sulfuric Acid (20% Oleum)	4	4	4	1
Sulfuric Acid (conc.)	4	4	4	1

REFERENCE

Lip Codes: N = Nitrile P = Polyacrylate S = Silicon F = Fluorocarbon

Ratings: 1 = Minor Affect 2 = Moderate Affect 3 = Static Only 4 = Not Recommended
 -- = Insufficient Data (AQ) = Aqueous

CHEMICAL	SEALING MATERIAL			
	N	P	S	F
Sulfuric acid (dilute)	3	2	4	1
Sulfuric Acid 3 Molar	4	--	4	1
Sulfurous Acid	2	4	4	1
Sunoco #3661	1	--	4	1
Sunoco all purpose grease	1	--	4	1
Sunoco SAE 10	1	--	4	1
Sunsafer (fire resistant Hydr. fluid)	1	--	--	1
Super shell gas	1	--	4	1
Swan Finch EP lube	1	--	4	1
Swan Finch Hypoid	1	--	4	1
Tannic Acid	1	4	2	1
Tar, Bituminous	2	4	2	1
Tartaric acid	1	--	1	1
Terpineol	2	--	--	1
Tertiary-Butyl Alcohol Turbine oil #15 (MIL-L-7808A)	2	--	4	1
Turbo oil #35	1	--	4	1
Turpentine	1	2	4	1
Type I fuel (MIL-S-3136)	1	--	4	1
Type II fuel (MIL-L-3136)	2	--	4	1
Type III fuel (MIL-L-3136)	2	--	4	1
Ucon Hydrolube J-4	1	--	1	1
Ucon Lubricant 50-HB100	1	--	1	1
Ucon Lubricant 50-HB260	1	--	1	1
Ucon Lubricant 50-HB5100	1	--	1	1
Ucon Lubricant 50-HB55	1	--	1	1
Ucon Lubricant 50-HB660	1	--	1	1
Ucon Lubricant LB-1145	1	--	1	1
Ucon Lubricant LB-135	1	--	1	1
Ucon Lubricant LB-285	1	--	1	1
Ucon Lubricant LB-300	1	--	1	1

REFERENCE

Lip Codes: N = Nitrile P = Polyacrylate S = Silicon F = Fluorocarbon

Ratings: 1 = Minor Affect 2 = Moderate Affect 3 = Static Only 4 = Not Recommended
 -- = Insufficient Data (AQ) = Aqueous

CHEMICAL	SEALING MATERIAL			
	N	P	S	F
Ucon Lubricant LB-625	1	--	1	1
Ucon Lubricant LB-65	1	--	1	1
Ucon oil LB-385	1	--	1	1
Ucon oil LB-400X	1	--	1	1
Ultra-violet light	4	2	1	1
Univis (Hydraulic fluid)	1	--	4	1
Univolt #35 (mineral oil)	1	--	4	1
Varnish	2	4	4	1
Vegetable oils	1	1	2	1
Versilube F-50	1	1	3	1
Vinegar	2	4	1	1
Vinyl Chloride	4	4	--	1
W-B-680	2	2	4	1
W-G-632	1	1	3	1
W-G-671C	1	1	3	1
W-H-910	2	2	4	1
W-I-530A	1	1	3	1
W-K-211D	1	--	4	1
W-K-220A	1	2	4	1
W-L-751B	2	2	4	1
W-L-800	1	1	3	1
W-L-820B	1	1	3	1
W-L-825A Type I	1	1	3	1
W-L-825A Type II	1	1	3	1
W-L-825A Type III	2	2	4	1
W-O-526	1	1	3	1
W-P-216A	1	1	3	1
W-P-236	2	2	4	1
Wagner 21B brake fluid	3	--	3	4
Water	1	4	1	1
Wemco	1	--	4	1

REFERENCE

Lip Codes: N = Nitrile P = Polyacrylate S = Silicon F = Fluorocarbon

Ratings: 1 = Minor Affect 2 = Moderate Affect 3 = Static Only 4 = Not Recommended
 -- = Insufficient Data (AQ) = Aqueous

















































































CHEMICAL	SEALING MATERIAL			
	N	P	S	F
Whiskey, wines	1	4	1	1
White gas	2	4	4	1
White oil	1	1	4	1
White pine oil	2	--	4	1
Wolmar salt	1	--	1	1
Wood alcohol	1	--	1	1
Wood oil	1	1	4	1
Xenon	1	--	1	1
Xylene	4	4	4	1
Xylidine (Di-Methyl Aniline)	3	4	4	4
Xylol	4	--	4	1
Zeolites	1	--	--	1
Zinc Acetate (AQ)	2	4	4	4
Zinc Chloride (AQ)	1	4	1	1
Zinc salts	1	--	1	1

Lip Codes: N = Nitrile P = Polyacrylate S = Silicon F = Fluorocarbon

Ratings: 1 = Minor Affect 2 = Moderate Affect 3 = Static Only 4 = Not Recommended
 -- = Insufficient Data (AQ) = Aqueous

REFERENCE

PROFILE MATRIX

	1	2	3	4	5	6	7	8
A	SCJ 	SBJ 	SBH 	SBS 	SCL 	SCL6 	SB2T 	SB2L 
B	TCJ 	TBJ 	TBH 	TBS 	TCL 	TCL6 	TB2T 	TB2L 
C	VCJ 	VBJ 	VBH 	VBS 	VCL 	VCL6 	VB2T 	VB2L 
D	KCJ 	KBJ 	KBH 	KBS 	KCL 	KCL6 	KB2T 	KB2L 
E	DCJ 	DBJ 	SBM 	DBS 	DCL 	DCL6 	DB2T 	TBM 
F	SB2T 	SBT 	SCT 	UBS 	SCLT 	SAM 	TCLT 	TAM 
G	TB2T 	TBT 	TCT 	VCLT 	VAM 	VBM 	KBM 	DCLT 
H	VB2T 	VBT 	VCT 	KB2T 	KBT 	KCT 	KCLT 	KAM 
I	DB2T 	DBT 	DCT 	OSA2 	OSB2 	OSB 	OSBR 	OSC 
J	OTA2 	OTB2 	OTB 	OTBR 	OTC 	OVB 	OVBR 	OVC 

REFERENCE

PROFILE MATRIX

	1	2	3	4	5	6	7	8
A	OVA2 	OVB2 	OKA2 	OKB2 	OKB 	OKBR 	OKC 	SCN 
B	OUA2 	OUB2 	OUB 	OUBR 	OUC 	SCN1 	TCN1 	TDN 
C	SB4 	TB4 	SC4 	DC4 	TBR8 	TC8 	TC9 	TBC9 
D	RVS 	RO 	ROE 	SA2C 	SB2C 	SCC 	TA2C 	TB2C 
E	TCC 	EBC 	EBG 	ECS 	ECJ 	VA2 	VBR 	VC 
F	VBC 	VBJ 	VBH 	V13 	V16 	V10 	V15 	KA2 
G	KBR 	KC 	KBR 	KBJ 	KBH 	KBS 	KAM 	KBP 
H	KCL 	SA2 	SBR 	SC 	SBC 	SBJ 	SBH 	SBS 
I	SAM 	SBP 	SUA2 	TA2 	TBR 	TC 	TBC 	TBJ 
J	TBH 	TCL 	T11 	TC8 	TC9 	DB2 	DA2 	DBR 

REFERENCE

PROFILE MATRIX

	1	2	3	4	5	6	7	8
A	DBC 	DAP 	TSL8 	TSL9 	TSL10 	WPC 	WPR 	WPK 
B	WPB2 	OSB2 	OTB2 	OKB2 	OUA2 	OUBR 	OUC 	OUB10 
C	OUA20 	UA2 	UBR 	UC 	UB10 	UA20 	XB2 	XA2 
D	XBR 	XC 	XBC 	XBP 	LC 	LCO 	NBC 	VSB 
E	VSB5 	TGT1 	TCK 	XCJ 	XBJ 	XBH 	XBS 	XB2L 
F	TCN 	TC4 	RVA 	EC 	VB2 	KB2 	SB2 	DC 
G	UB2 	OUB2 	OVB2 	WPB 	FL 	EVO 		

REFERENCE

locations

World Headquarters:

5920 Dry Creek Lane NE
Cedar Rapids, IA 52402
Ph: 1.888.ESP.9002 (toll free) | Fax: 319.393.5327

Industrial Seal Headquarters:

10460 Markison Road
Dallas, TX 75238
Ph: 1.800.777.6327 (toll free) | Fax: 214.503.9990

Regional Office:

2415 Annapolis Lane
Plymouth, MN 55441
Ph: 763.550.9425 | Fax: 763.550.9427

India Headquarters:

No 185, First Main Road, Nehru Nagar
Kotivakkam, India
Chennai -600 041
Ph: 91-44-24540506

Asia/China Headquarters:

Pan Ten 2nd Industrial
Bugu Town Long Gang District
Shenzhen, China
Ph: 86.755.8419.2746

www.espint.com

Procurement and Logistics:

No. 33-9, Sanguang Lane Beitun District
Taichung City 40646, Taiwan (R.O.C)

Machining, Fabrication and Assembly:

1140 Hubbard Ave NE
Cedar Rapids, IA 52402
Ph: 319.393.4310 | Fax: 319.3935327

Metal Machining Facility:

No. 33, Yang Jiang East Road
PaoJiang Zone
Shaoxing, Zhejiang 312000 China

